



HIGH QUALITY IN ALUMINIUM

CATÁLOGO TÉCNICO

# GERAL DE PERFIS



**A CDA Metais** atua no desenvolvimento de sistemas de esquadrias e fachadas, extrusão, pintura eletrostática e distribuição de alumínio para todo o Brasil. Soluções completas em alumínio.

Saiba mais: [www.cdametais.com.br](http://www.cdametais.com.br)



## EMPRESAS



A integração dos processos de extrusão, pintura e distribuição de perfis e laminados em alumínio, confere agilidade na qualidade do atendimento ao cliente CDA Metais.



A Total Ink, assina as operações de pintura eletrostática da CDA, concebidas para oferecerem o que há de mais moderno no mercado mundial de tratamento de superfície. Privilegia a alta produtividade e garante a qualidade do produto final, com certificados fornecidos em conjuntos com os fornecedores de tintas e produtos químicos.



Consolidou-se sistemista no segmento, com larga experiência na distribuição de perfis e laminados de alumínio. Com corpo técnico capacitado, desenvolve ferramental e auxilia na especificação de seus produtos juntos aos fabricantes, consumidores e consultores.



A operação das unidades de extrusão de perfis de alumínio garante autonomia e agilidade para atender os setores da construção civil e indústria de forma personalizada, com rapidez e eficiência.

**CDA Metais. Alta performance em alumínio.**



## SUSTENTABILIDADE

A CDA tem por meta a sustentabilidade dos edifícios, não só através do isolamento térmico mas também considerando a eficiência energética e a proteção do clima durante o ciclo de vida do alumínio. O nosso alumínio passa por uma gestão cuidadosa dos seus recursos naturais, começando com a produção de alumínio usando 68% da energia a partir da hidrelétrica, usando processos de reciclagem.

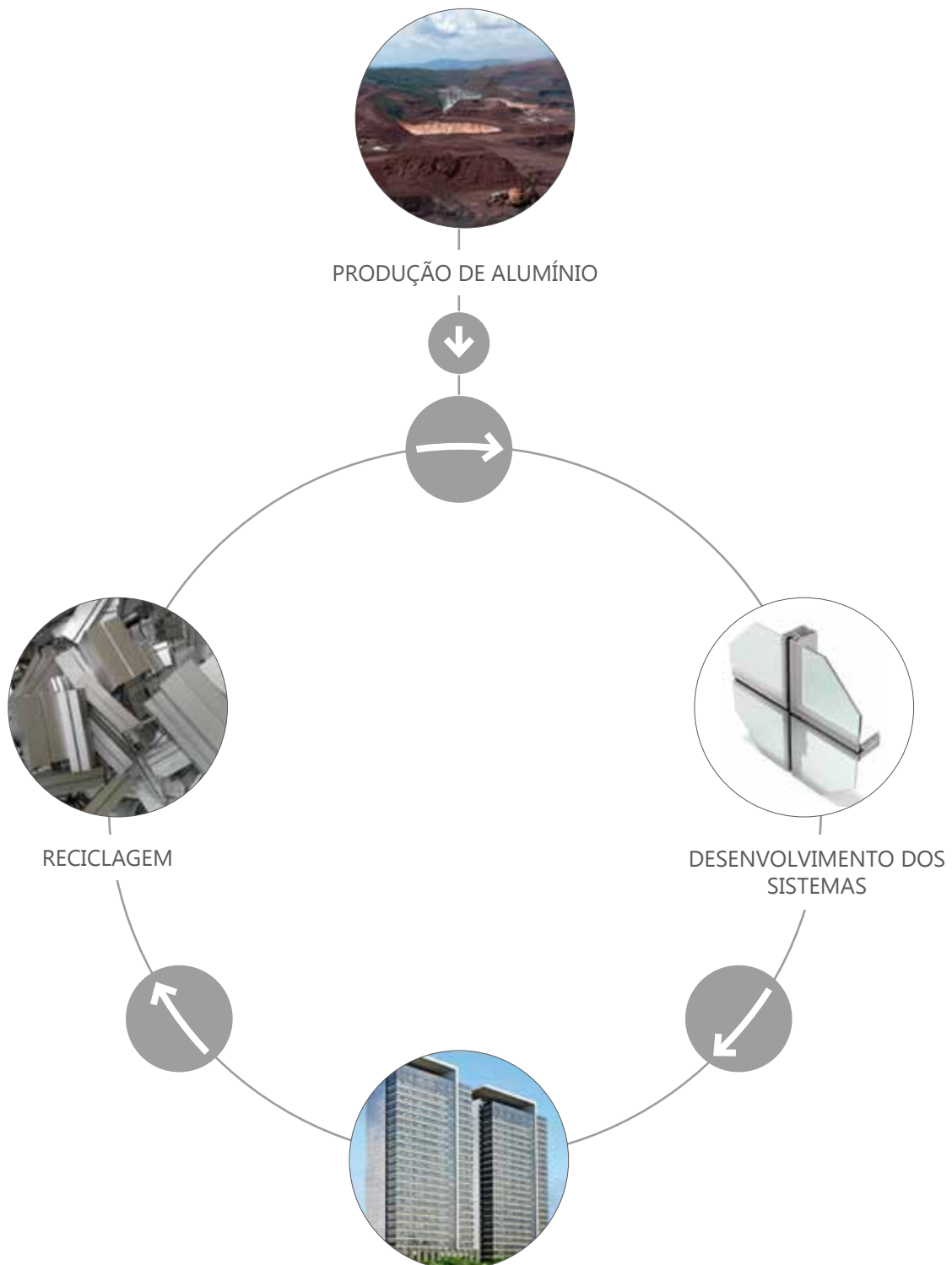



## ENDEREÇOS

### Divisão Comercial

#### Unidade CDA Santo André

Av. Dos Estados, 3913 – Santa Teresinha  
Santo André – SP - 09210580  
PABX: (11) 4996-7000 ou 4996-7100  
FAX: (11) 4996-7138  
E-mail: cdabr@cdametais.com.br

#### Unidade CDA Diadema

Av. Maria Leonor, 1067 – Jardim Campanário  
Diadema – SP – 09920-080  
PABX: (11) 4093-9900 ou 3623-2233  
FAX: (11) 4093-9988  
E-mail: cdametais@cdametais.com.br

#### Unidade CDA Curitiba

Av. Senador Salgado Filho, 216 C – Prado Velho  
Curitiba – PR – 80215-270  
PABX: (41) 3063-3000  
FAX: (41) 3063-3004  
E-mail: cdapr@cdametais.com.br

#### Unidade CDA Rio de Janeiro

Av. Postal, 34 – Ramos  
Rio de Janeiro – RJ – 21040-150  
PABX: (21) 3534-5300  
FAX: (21) 3534-5305  
E-mail: cdarj@cdametais.com.br

#### Unidade CDA Porto Alegre

Av. das Indústrias, 130 – São João  
Porto Alegre – RS – 90200-290  
PABX: (51) 3373-2333  
FAX: (51) 3373-2300  
E-mail: cdars@cdametais.com.br

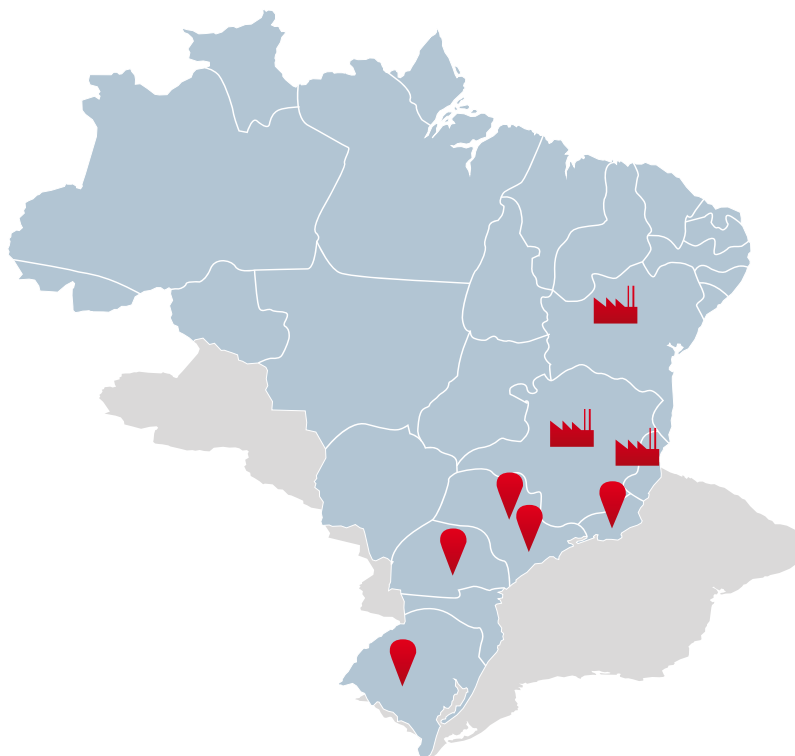

## CERTIFICAÇÕES E PRÊMIOS

### A CDA atualmente atende a norma NBR ISO 9001:2008 de Qualidade

A melhoria contínua da organização é constantemente monitorada através de indicadores de desempenho.

Metas são definidas pela Diretoria e desdobradas a todos os níveis, garantindo o alcance das mesmas com o envolvimento de todos.



<b>Empresa</b> .....	1.001
<b>Informações Técnicas</b> .....	2.001
<b>Sumário de Perfis</b> .....	3.001

## Tabelados

Barras Chatas.....	4.001
Cantoneira Abas Iguais.....	4.001
Cantoneira Abas Desiguais.....	4.002
Tubos Redondos.....	4.002
Tubos Retangulares Arredondados.....	4.003
Tubos Retangulares.....	4.003
Tubos Quadrados.....	4.004
Perfil U Abas Iguais.....	4.005
Perfil U Abas Desiguais.....	4.005
Perfil T.....	4.005
Vergalhão Redondo.....	4.006
Vergalhão Quadrado.....	4.006

## Mercado - Perfis

Contramarcos.....	5.001	Linha Integrada.....	17.001
Conexões.....	6.001	Fachada Cortina.....	18.001
Arremates.....	7.001	Pele de Vidro.....	19.001
Linha 23.....	8.001	Linha Gradil.....	20.001
Linha 25.....	9.001	Portão.....	21.001
Linha 28.....	10.001	Venezianas.....	22.001
Linha 30.....	11.001	Lambris.....	23.001
Linha 42.....	12.001	Brises.....	24.001
Módulo Standard.....	13.001	Box.....	25.001
Módulo Prático.....	14.001	Divisórias.....	26.001
Módulo Especial.....	15.001	Diversos.....	27.001
Módulo Max.....	16.001		

## Sistema - Perfis



Linha Van Gogh.....	28.001	Linha Guilhotina.....	34.001
Linha Absoluta.....	29.001	Linha Shadow.....	35.001
Linha D'oro.....	30.001	Linha Rembrandt.....	36.001
Linha Renoir.....	31.001	Linha Da Vinci.....	37.001
Linha Matisse.....	32.001	Linha Monet.....	38.001
Linha Mondrian.....	33.001		

## Industrial - Perfis

Automotivo.....	39.001	Luminosos.....	42.001
Dissipadores.....	40.001	Vitrine.....	43.001
Equipamentos.....	41.001		

## EQUIVALÊNCIA ENTRE NORMAS

Liga ASTM	ABNT/Brasil	Alemanha (DIN)	Inglaterra (BS)	Itália (UNI)	França (NF ou AIR)
1050	1050	AI 99,5	1B	P-AI-P 99,5	A5
1100	1100	AI 99,0	1C	P-AI-P 99,0	A4
1350	1350	E-AI99,5	1E	-	A5/L
6005A	6005A	AI Mg Si 0,7	-	-	-
6060	6060	AI Mg Si 0,5	H-9	P-Ai Si 0,4 Mg	A-GS
6061	6061	AI Mg Si Cu	H-20	P-AI Mg1 Si Cu	A-GSUC
6063	6063	AI Mg Si 0,5	H-9	P-AI Mg Si	A-GS
6101	6101	E-AI Mg Si 0,5	91E	P-AI Si 0,5 Mg	A-G S/L
6261	6261	-	-	-	-
6351	6351	AI Mg Si	H-30	P-AI Si Mg Mn	A-SGM
6463	6463	-	-	P-AI Mg Si / Cu	-

## CARACTERÍSTICAS FÍSICAS DO ALUMÍNIO E OUTROS MATERIAIS

Propriedades físicas	Alumínio (1100)	Aço (1020)	Cobre (Puro)
Peso específico (kg/m <sup>3</sup> ) x 10 <sup>3</sup>	2,71	7,86	8,96
Temperatura de fusão (°C)	657	1500	1083
Módulo de elasticidade (kg/mm <sup>2</sup> )	7.000	21.000	11.250
Coefficiente de dilatação térmica linear - 20 <sup>o</sup> a 100 <sup>o</sup> C (M/M.K)	23,6x10 <sup>-6</sup>	11,7.10 <sup>-6</sup>	16,5.10 <sup>-6</sup>
Condutibilidade térmica a 25°C (W/M.K)	222	52	394
Condutibilidade elétrica (%IACS) à 20°C	59	14,5	100

## COMPOSIÇÃO QUÍMICA

ASTM	Si	Fe	Cu	Mn	Mg	Cr	Zn	i	Outros elementos		Alumínio (Mínimo)
									Cada	Total	
1050	0,25	0,40	0,05	0,05	0,05	-	0,05	0,03	0,03	-	99,50
1100	1,0	Si+Fe	0,05-0,20	0,05	-	-	0,10	-	0,05	0,15	99,00
1350	0,10	0,40	0,05	0,01	-	0,01	0,05	Ti+V <0,02	0,03	0,10	99,50
6005A	0,50-0,90	0,35	0,30	0,50	0,40-0,70	0,30	0,20	0,10	0,05	0,15	Restante
6060	0,30-0,6	0,10-0,30	0,10	0,10	0,35-0,60	0,05	0,15	0,10	0,05	0,15	Restante
6061	0,40-0,80	0,70	0,15-0,40	0,15	0,80-1,2	0,04-0,35	0,25	0,15	0,05	0,15	Restante
6063	0,20-0,60	0,35	0,10	0,10	0,45-0,90	0,10	0,10	0,10	0,05	0,15	Restante
6082	0,7-1,3	0,50	0,10	0,40-1,0	0,60-1,2	0,25	0,20	0,10	0,05	0,15	Restante
6101	0,30-0,70	0,50	0,10	0,03	0,35-0,8	0,03	0,10	-	0,03	0,10	Restante
6261	0,40-0,70	0,40	0,15-0,40	0,20-0,35	0,7-1,0	0,10	0,20	0,10	0,05	0,15	Restante
6351	0,7-1,3	0,50	0,10	0,40-0,8	0,40-0,8	-	0,20	0,20	0,05	0,15	Restante
6463	0,2-0,6	0,15	0,2	0,05	0,45-0,9	-	0,05	0,03	0,05	0,15	Restante

Os valores mencionados indicam porcentagens em peso e representam limites máximos, salvo quando exposto intervalo.  
A composição química é equivalente a norma ASTM-B221 (ABNT-NBR 6834)

# INFORMAÇÕES TÉCNICAS

PROPRIEDADES MECÂNICAS											
Propriedades de liga			Limite de resistência à tração Kg /mm <sup>2</sup>	Limite de escoamento Kg /mm <sup>2</sup>	Alongamento em 50 mm (%)	Dureza bri-nell 500/10 HB(2)	Limite de Resistência ao cisalhamento Kg/mm <sup>2</sup>	Resistência a Fadiga 500x10 6 Ciclos (Kg/mm <sup>2</sup> )			
Liga	Aplicações típicas	Têmpera									
1050	Equipamentos para indústrias químicas, alimentícias e de bebidas	0	9,8 (9,1)	- (3,2)	- (45)	- (20)	- (5,6)	- (2,8)			
		H14	10,5 (11,2)	- (9,8)	- (35)	- (32)	- (7,0)	- (3,5)			
		H18	13,4 (14,4)	- (13,7)	- (22)	- (40)	- (8,4)	- (4,9)			
		H24	- (11,2)	-	-	-	-	-			
1100	Painéis decorativos, etiquetas, utensílios domésticos, uso geral, peças estampadas, aletas.	0	10,7*	- (3,5)	- (45)	- (23)	- (6,3)	- (3,5)			
		H12	9,7	-	-	-	-	-			
		H14	11,2 (12,0)	- (11,2)	- (25)	- (34)	- (7,7)	- (4,9)			
		H16	13,3	-	-	-	- (8,4)	- (5,5)			
		H18	15,4 (21,0)	- (16,1)	- (20)	- (44)	- (9,1)	- (6,3)			
		F	-	-	-	-	-	-			
1200	Equipamento para indústrias químicas, alimentícias e de bebidas	0	10,9*	- (3,5)	- (45)	- (23)	- (16,3)	- (3,5)			
		H14	11,2 (12,0)	- (11,2)	- (25)	- (32)	- (7,7)	- (4,9)			
		H18	15,4 (21,0)	- (16,1)	- (20)	- (44)	- (9,1)	- (6,3)			
2117	Rebites	T4	26,7 (30,2)	12,6 (17,0)	18 (27)	- (70)	18,3 (19,7)	- (13,5)			
2017	Peças com elevada resistência mecânica - usinagem	0	24,6 (18,3)	- (9,8)	16 (30)	- (45)	- (12,7)	- (9,1)			
		T4	38,7 (45,7)	22,5 (29,6)	16 (24)	- (105)	- (26,7)	- (12,6)			
2024	Peças com elevada resistência mecânica - forjagem	0	24,6* (22,5)	13,3* (11,2)	12 (15)	- (42)	- (12,6)	- (8,4)			
		T4	40,0 (45,7)	29,5 (36,5)	12 (17)	- (105)	- (28,8)	- (12,6)			
2014	Peças com elevada resistência mecânica - forjagem	0	21,1* (20,4)	12,6* (10,5)	12 (14)	- (45)	- (12,6)	- (7,7)			
		T4	35,1 (43,6)	24,6 (29,5)	12 (18)	- (105)	- (26,7)	- (12,6)			
		T6	42,2 (47,1)	37,2 (42,9)	7 (11)	- (135)	- (31,6)	- (12,6)			
2011	Peças usinadas em torno automático	T3	30,1 (33,9)	23,8 (29,7)	10 (15)	- (95)	- (21,0)	- (12,6)			
		T6	29,6 (34,0)	- (23,0)	- (16)	-	-	-			
		T8	- (41,5)	- (31,5)	- (12)	- (100)	- (24,5)	- (12,5)			
4043	Solda	-	-	-	-	-	-				
4047	Solda	-	-	-	-	-	-				
6063	Caixilharia e ornamentos - anodização fosca	0	11,9* (10,5)	- (3,5)	- (40)	- (26)**	- (7,7)	- (5,5)			
		T4A	11,1 (14,1)	6,0 (8,4)	16 (25)	- (48)**	- (10,0)	- (6,5)			
		T5	15,4 (19,6)	11,9 (16,8)	8 (16)	- (66)	- (12,0)	- (7,0)			
		T6C	18,3 (22,1)	14,8 (19,7)	8 (14)	- (68)	- (15,5)	- (7,0)			
		T8A	21,0 (28,0)	17,5 (25,2)	8 (13)	-	- (15,5)	-			
		T8D	25,9 (30,8)	23,8 (28,7)	7 (12)	-	- (12,5)	-			
		T8E	- (19,0)	- (17,0)	- (10)	-	- (19,0)	-			
6463	Frisos decorativos com alta refletividade	T4A	- (14,0)	- (7,0)	- (20)	- (42)	- (10,0)	- (7,0)			
		T6C	- (24,0)	- (21,0)	- (12)	- (74)	- (15,5)	- (7,0)			
6101	Aplicação elétrica - boa resistência mecânica	T5	- (18,5)	- (15,0)	-	-	-	55,0			
		T6	20,4 (25,5)	17,5 (23,0)	- (13)	- (78)	%IACS	55,0			
		T6A	19,0 (21,0)	15,5 (18,0)	-	- (62)	-	56,0			
		T6B	14,0 (18,0)	10,5 (14,0)	- (20)	- (54)	-	57,0			
6351	Estruturas e pesas usinadas	0	- (12,6)	- (5,6)	- (25)	-	-	-			
		T4	19,0 (25,3)	11,9 (15,5)	18 (20)	- (60)	- (15,5)	- (9,5)			
		T6	29,5 (32,3)	26,0 (30,2)	10 (13)	- (95)	- (20,5)	- (9,5)			
6053	Rebites	T4	17,6 (21,1)	-	-	-	11,9	-			
		T6	22,5 (24,6)	14,1	14	- (70)	15,5 (18,3)	- (9,0)			
5056	Rebites e Solda	0	31,6* (29,5)	- (14,1)	10 (35)	- (65)	- (18,3)	- (14,1)			
		H34	33,0 (35,2)	- (28,1)	- (20)	- (95)	- (20,4)	- (14,8)			
		H38	38,7 (40,7)	- (33,7)	-	- (100)	- (22,5)	- (15,5)			
5052	Estrutura (expostas ao ar marinho)	0	21,8* (20,4)	- (9,8)	25 (30)	- (45)	- (12,6)	- (11,2)			
		H34	23,9 (26,0)	- (20,4)	- (14)	- (67)	- (14,7)	- (12,6)			
		H38	27,4 (30,2)	- (26,7)	- (8)	- (80)	- (16,9)	- (14,1)			
6061	Estruturas e Rebites	0	15,5* (14,1)	11,2* (8,4)	16 (24)	- (30)	- (8,5)	- (6,3)			
		T4	18,3 (24,6)	11,2 (14,8)	16 (20)	- (65)	- (15,5)	- (9,8)			
		T6	26,7 (31,0)	24,6 (28,2)	10 (16)	- (95)	- (19,0)	- (9,8)			
		T9	35,1 (36,6)	- (33,0)	12 (18)	-	-	-			
6261	Estruturas	T4	- (22,0)	- (13,0)	- (17)	- (70)	-	-			
		T4A	- (19,0)	- (11,0)	- (17)	- (60)	-	-			
		T6	28,0 (30,0)	25,4 (27,0)	10 (12)	- (95)	-	-			
		T6C	23,4 (27,0)	20,3 (23,0)	7 (10)	- (85)	-	-			

## PROPRIEDADES MECÂNICAS

6261	Peças usinadas em torno automático	T3	-	(35,7)	-	(34,7)	-	(7)	-	(104)	-	-	-	-
		T4	-	(27,4)	-	(18,3)	-	(18)	-	(63)	-	-	-	-
		T6	-	(37,0)	-	(32,4)	-	(15)	-	(90)	-	-	-	-
		T8	-	(41,4)	-	(39,8)	-	(12)	-	(104)	-	-	-	-
7104	Estruturas	T4A	20,8	(23,4)	13,1	(16,1)	13	(16)	-	(70)	-	-	-	-

OBS.: (-) = Os valores entre parênteses são típicos, correspondem uma média de valores observados.

\* = Indica-se o valor máximo para garantir um completo recozimento.

## CARACTERÍSTICAS ESPECÍFICAS

Liga	Resistencia à corrosão	Anodização		Solda MIG	Solda TIG	Usinagem	Deformabilidade a frio	Brasagem	Outras
		Decorativa	Protetora						
1050	A	A	A	A	A	E	A	A	-
1100	A	A	A	A	A	E	A	A	-
1350	A	A	A	A	A	E	A	A	-
6005A	A	C	A	A	A	C	C	B	-
6060	A	A	A	A	A	D	B	A	-
6061	A	D	A	A	A	C	C	B	-
6063	A	A	A	A	A	D	B	A	-
6101	A	A	A	A	A	D	B	A	-
6261	A	C	A	A	A	C	C	B	-
6351	A	D	A	A	A	C	C	C	-
6463	A	A	A	A	A	D	B	A	-

Índices de "A até E" em ordem de mérito

N - Não apropriado

## TOLERÂNCIA DE DIMENSÕES

### Extrusão

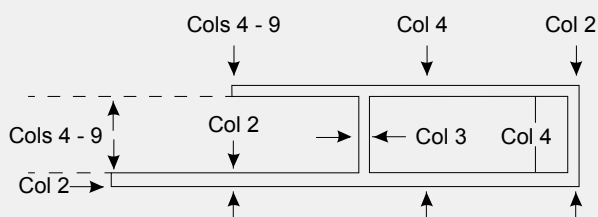

- Para os produtos extrudados são adotadas as tolerâncias contidas na norma ABNT NBR 8116 - alumínio e suas ligas - que é baseada na ASTM (ANSI H35.2 - M);
- Dadas as necessidades de constante atualização da norma NBR 8116, devido aos avanços das indústrias produtoras de alumínio e as necessidades cada vez maiores das indústrias usuárias de perfis extrudados, os valores constantes desta tabela estão sujeitos a mudanças;
- Nesta página, apresentaremos apenas a tabela mais usual, sendo que informações complementares poderão ser obtidas com os técnicos da Perfil;
- A tabela apresenta as tolerâncias padronizadas;
- Quando nenhuma tolerância é mostrada, deve ser estabelecida de comum acordo entre o comprador e o fornecedor.

## TOLERÂNCIA DE DIMENSÕES

Dimensão nominal (mm)	Tolerância na seção transversal do perfil							
	Dimensões do metal				Dimensões entre superfícies metálicas			
	Dimensão nominal onde 75% ou mais é metal (E) (F)				Desvio permissível da dimensão nominal quando mais de 25% da dimensão for vazio (G) (H)			
	Todas as dimensões exceto aquelas incluídas na coluna 3	Espessuras de parede, circunscrito um vazio de 70 mm ou mais (I) (J)	Nas dimensões medidas a uma distância "A" da base da aba					
5 a 15			15 a 30	30 a 60	60 a 100	100 a 150	150 a 200	
C oluna								
1	2	3	4	5	6	7	8	9
até 3,2	0,15	± 10% da espessura especificada Máximo: ± 1,50 Mínimo: ± 0,25	0,25	0,30	-	-	-	-
3,2 a 6,3	0,18		0,30	0,36	0,41	-	-	-
6,3 a 12,5	0,20		0,36	0,41	0,46	0,50	-	-
12,5 a 20	0,23		0,41	0,46	0,50	0,56	-	-
20 a 25	0,25		0,46	0,50	0,56	0,64	0,76	-
25 a 40	0,30		0,54	0,58	0,66	0,76	0,88	-
40 a 50	0,36		0,60	0,66	0,78	0,92	1,05	1,25
50 a 100	0,60		0,86	0,96	1,20	1,45	1,70	2,05
100 a 150	0,86		1,10	1,25	1,65	2,00	2,40	2,80
150 a 200	1,10		1,35	1,55	2,40	2,50	3,05	3,55
200 a 250	1,35		1,65	1,90	2,50	3,05	3,70	4,30

- Vergalhões, barras e perfis extrudados. Tolerâncias na seção transversal em milímetros para mais ou para menos. Essas tolerâncias aplicam-se a perfis extrudados exceto na têmpera "0" (estado cozido) e "F" (como fabricado).
- **(A)** Estas tolerâncias-padrão aplicam-se a perfis comuns; podem ser necessárias tolerâncias mais amplas para alguns perfil e podem ser possíveis tolerâncias mais estreitas para outros, dependendo do acordo prévio entre o comprador e o fornecedor.
- **(B)** As tolerâncias para perfis extrudados nas ligas e têmperas especiais devem ser negociadas entre o comprador e o fornecedor.
- **(C)** A tolerância aplicável a uma dimensão composta de dois ou mais componentes é a soma da stolerâncias das dimensões componentes, se todas elas forem indicadas.
- **(D)** Se uma tolerância dimensional especificada não for simétrica, então o valor da tolerância-padrão a ser aplicado é aquele que seria aplicado à média das dimensões máxima e mínima permissíveis pela tolerância inicialmente especificada.
- **(E)** Estas tolerâncias não se aplicam a dimensões "X" e "Z" do exemplo, mesmo quando "Y" for 75% ou mais de "X". Para as tolerâncias aplicáveis às dimensões "X" e "Z" usar as colunas 4, 5, 6, 7, 8 e 9 dependendo da distância A.
- **(F)** A tolerância na espessura da parede dos perfis tubulares ou semitubulares deve ser combinada entre o comprador e o fornecedor, quando a espessura nominal de uma parede for três ou mais vezes maior que a parede oposta.
- **(G)** Nos pontos situados a 5 mm ou menos do início da aba, aplicam-se as tolerâncias da coluna 2.

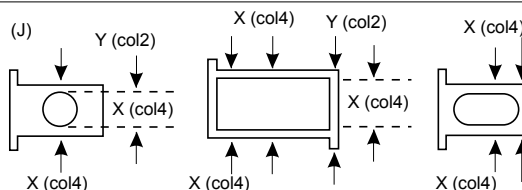
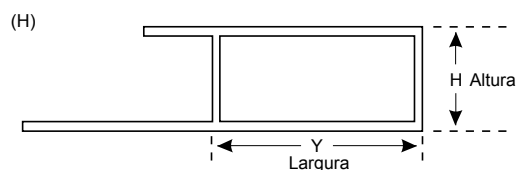
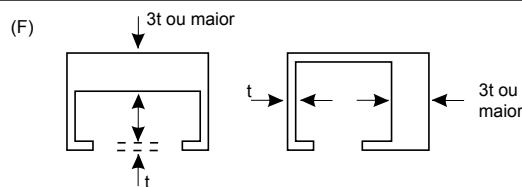
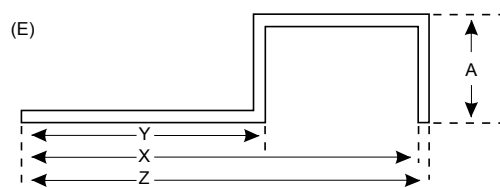



- **(H)** As seguintes tolerâncias são aplicadas no caso de perfis tubulares:
  - » Para a largura (L), a tolerância é a indicado na coluna 4 para a altura (H);
  - » Para a altura (H), a tolerância é a indicada na largura (L);
  - » Em nenhum caso pode a tolerância para a largura ou altura ser menor que a tolerância para os cantos (coluna 2, dimensões do metal).
  - » Exemplo de um perfil tubular tendo as dimensões externas retangulares de (25 x 75 mm):
- » A tolerância na largura é 0,46 mm e a tolerância nos cantos (coluna 2, dimensões do metal) é 0,60 mm para a largura e 0,25 mm para a altura. Notar que a tolerância de 0,46 mm na coluna 4 deve ser ajustada a 0,60 mm para não ficar menor que a tolerância na coluna 2.
- **(I)** Quando as dimensões especificadas forem externas e internas. Ao invés da própria espessura da parede, o desvio permissível (excentricidade) indicado na coluna 3 se aplica à espessura média da parede.
- **(J)** No caso de perfis tubulares normais, aplica-se a tolerância-padrão para a espessura-padrão, para espessura da parede dos tubos redondos extrudados.

## EXEMPLOS

- **(A)** Dimensões de vazios internos (perfis tubulares): todas as dimensões indicadas por "Y" são classificadas como "dimensões do metal" obedecendo às tolerâncias indicadas na coluna 2. Dimensões indicadas por "X" são classificadas como "dimensões incluindo vazios internos", sendo as tolerâncias aplicáveis determinadas pela coluna 4, a não ser que 75% ou mais da dimensão seja metal, caso este em que se aplica a coluna 2.
- **(B)** Dimensões dos vazios não totalmente circunscritos por metal. As tolerâncias aplicáveis à dimensão "X" podem ser enquadradas num dos três casos a seguir:
  - » Localizar a dimensão (X) na coluna 1;
  - » Determinar que coluna, de 4 a 9, é aplicável, dependendo da distância (A);
  - » Localizar a tolerância correta entre as colunas 4 e 9, na mesma linha que a dimensão (X);
  - » As dimensões (Y) correspondem às do metal e as tolerâncias são determinadas pela coluna 2;
  - » As distâncias (C) são mostradas somente para indicar dimensões incorretas, que não devem ser utilizadas para determinar que coluna, de 4 a 9, deve de aplicar;
  - » Localizar a distância (B) na coluna 1;
  - » Determinar que coluna, de 4 a 9, é aplicável dependendo da distância (A);
  - » Localizar a tolerância correta entre as colunas 4 e 9, na mesma linha do valor escolhida na coluna 1;
  - » As tolerâncias aplicáveis às dimensões (X) não são determinadas pela tabela e sim pelas tolerâncias-padrão aplicáveis aos ângulos (A).

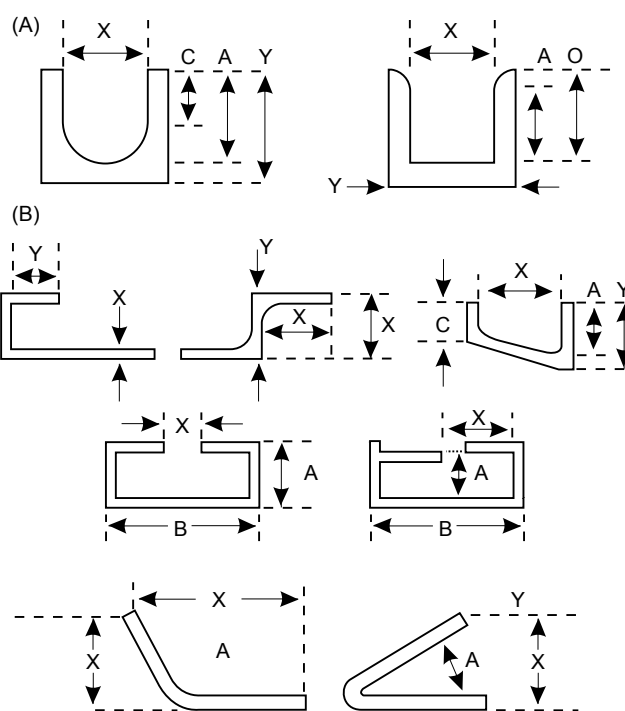

# INFORMAÇÕES TÉCNICAS

## RETILINEARIDADE

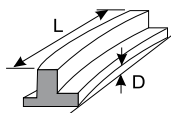

Diâmetro do menor círculo circunscrito (mm) (1)	Espessura mínima (mm)	Desvio (D) permitido por metro de comprimento (mm) (2)
Até 38,09	Até 2,4	4,0
Até 38,09	Acima de 2,4	1,0
Acima de 38,10	Qualquer	1,0

## TORÇÃO

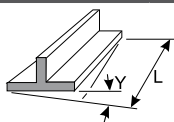

Diâmetro do menor círculo circunscrito (mm) (1)	Desvio permitido (graus)		
	Por metro de comprimento	No comprimento total	Torção máxima
Até 38,09	3,3	3,3 x L (metros)	7%
De 38,09 à 76,19	1,6	1,6 x L (metros)	5%
Acima de 76,20	0,8	0,8 x L (metros)	3%

## COMPRIMENTO

Diâmetro do menor círculo circunscrito (mm) (1)	Desvio permitido em relação ao comprimento nominal (somente a mais) (mm)		
	Comprimento nominal		
	Até 3.660	3.661 a 9.150	9.151 a 15.250
Até 76,19	3,2	6,4	9,5
76,20 a 203,19	4,8	7,9	11,1
Acima de 203,20	6,4	9,5	12,7

## ANGULARIDADE

Espessura mínima da aba (mm) (3)	Desvio permitido em relação ao ângulo nominal (graus) (4)
Até 4,75	+ 2,0
de 4,76 a 19,04	+ 1,5
acima de 19,05	+ 1,0

Corte Final - Desvio permitido do quadro, aproximadamente de 1°.

- Para vergalhões diâmetro nominal, para barras argura nominal;
- Para se obter o desvio permitido em barras de mais de 1 metro de comprimento multiplique-se o valor do comprimento em metros pelo valor do desvio por metro;
- Quando houver duas abas adjacentes considera-se a de menor espessura;
- Quando o espaço limitado pelo ângulo é todo metal, considera-se a menor espessura de metal no vértice do ângulo.

- a. Não é aplicado na tempera 0, tubos em rolos cuja espessura de parede for inferior a 0,5 mm ou 2,5% do diâmetro externo ou diâmetro da circunferência equivalente (diâmetro do círculo cuja circunferência mede o perímetro do tubo);
- b. Exemplo: em um tubo retangular extrudado de 76,20x38,10mm, a tolerância na largura (76,20) é de 0,63 mm e na altura (38,10) é de 0,89 mm.

## TOLERÂNCIAS DIMENSIONAIS DE DIÂMETRO EM TUBOS REDONDOS (ANSI - H35.2 - ABNT - NBR8116)

Diâmetro Nominal (mm)	Desvio permitido do diâmetro médio	Desvio permitido do diâmetro em qualquer ponto em relação ao diâmetro nominal (+_mm)(1)	
	$\frac{AA + BB}{2}$ em relação diâmetro nominal (+_mm)		
Tubos extrudados			
6,35 a 25,39	0,25	0,51	
25,40 a 50,79	0,30	0,64	
50,80 a 101,59	0,38	0,76	
101,60 a 152,39	0,64	1,27	
152,40 a 203,19	0,89	1,90	
203,20 a 253,99	1,14	2,54	
Tubos trefilados			
		Ligas não tratáveis termicamente	Ligas tratáveis termicamente
Até 12,73	0,08	0,08	0,15
12,74 a 25,40	0,10	0,10	0,20
25,41 a 50,80	0,13	0,13	0,25
50,81 a 76,20	0,15	0,15	0,30
76,21 a 127,00	0,20	0,20	0,41
127,01 a 152,40	0,25	0,25	0,51
152,41 a 203,20	0,38	0,38	0,76

## TOLERÂNCIAS DIMENSIONAIS DE ALTURA E LARGURA - TUBOS QUADRADOS, RETANG, SEXTAVADOS E OITAVADOS

Diâmetro Nominal (mm)	Desvio permitido da altura ou largura em relação à dimensão nominal (+_mm)		
	Nos cantos		Em lados opostos (a)
	Tubos quadrados e retangulares	Tubos quadrados sextavados e oitavados	
			Tubos retangulares
Tubos extrudados			
12,70 a 19,05	0,30	0,51	A tolerância para a largura é o valor da tolerância para uma dimensão igual a altura e inversamente, mas em nenhum caso esta tolerância é menor do que nos cantos. (b)
19,06 a 25,40	0,36	0,51	
25,41 a 50,80	0,46	0,63	
50,81 a 101,60	0,63	0,89	
101,61 a 126,70	0,89	1,14	
126,71 a 152,40	1,14	1,40	
Tubos trefilados			
Até 12,70	0,08	0,15	A tolerância para a largura é o valor da tolerância para uma dimensão igual a altura e inversamente, mas em nenhum caso esta tolerância é menor do que nos cantos. (b)
12,71 a 25,40	0,10	0,20	
25,41 a 50,80	0,13	0,25	
50,81 a 76,20	0,15	0,30	
76,21 a 127,00	0,20	0,41	
127,01 a 152,40	0,25	0,51	
152,41 a 203,20	0,38	0,76	

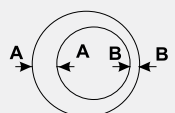
ESPESSURA DE PAREDE - TUBOS EXTRUDADOS TUBOS REDONDOS EXTRUDADOS					
Espessura nominal da parede (mm)	Desvio permitido da espessura média $\frac{AA + BB}{2}$ em relação à espessura nominal (+_mm)				Desvio permitido da espessura em qualquer ponto em relação à espessura média (+_mm)
					
	Diâmetro Externo (mm)				
	Até 31,75	31,75 a 76,19	76,20 a 126,99	acima de 127,00	
Até 1,19	0,15	--	--	--	10% de espessura média da parede.  Máximo: 1,52 Mínimo: 0,25
1,20 a 1,55	0,18	0,20	0,20	0,25	
1,56 a 1,95	0,20	0,20	0,23	0,30	
1,96 a 3,15	0,23	0,23	0,25	0,38	
3,16 a 6,34	0,23	0,23	0,33	0,51	
6,35 a 9,51	0,28	0,28	0,41	0,63	
9,52 a 12,69	--	0,38	0,53	0,89	
12,70 a 19,04	--	0,51	0,71	1,14	

ESPESSURA DE PAREDE TUBOS TREFILADOS			
Espessura nominal da parede (mm)	Desvio permitido da espessura média AA+BB em relação à espessura normal (+_mm)	Desvio permitido da espessura em qualquer ponto em relação à espessura nominal (+_mm)	
		Para tubos redondos em ligas não tratáveis termicamente	Para tubos redondos em ligas tratáveis termicamente e para outros tubos em qualquer liga (2)
0,25 a 0,89	0,05	0,05	
0,90 a 1,24	0,08	0,08	
1,25 a 2,10	0,10	0,10	
2,11 a 3,05	0,13	0,15	
3,06 a 5,16	0,15	0,20	
5,17 a 7,62	0,20	0,30	
7,63 a 9,52	0,38	0,51	
9,53 a 12,70	0,51	0,76	

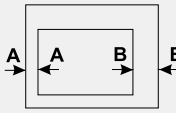
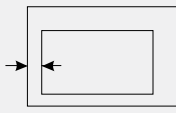
TUBOS QUADRADOS, RETANGULARES, SEXTAVADOS E OITAVADOS - EXTRUDADOS				
Espessura nominal da parede (mm)	Desvio permitido da espessura média AA+BB em relação à espessura normal (+_mm)		Desvio permitido da espessura em qualquer ponto em relação à espessura média (excentricidade)(+_mm)	
				
	DCC - Diâmetro do círculo circunscrito (mm)			
	menor que 127,0	maior que 127,0	menor que 127,0	maior que 127,0
Até 1,19	0,13	0,20	0,13	10% da espessura média da parede.  Máximo: 1,52 Mínimo: 0,25
1,20 a 1,55	0,15	0,23	0,18	
1,56 a 1,95	0,18	0,25	0,25	
1,96 a 3,15	0,18	0,25	0,25	
3,16 a 6,34	0,20	0,38	0,36	
6,35 a 9,51	0,28	0,51	0,63	
9,52 a 12,69	0,36	0,76	0,76	
12,70 a 19,04	0,63	1,02	1,02	

1. Para tubos em rolos deverão ser aplicados os valores para ligas tratáveis termicamente.
2. Para liga 50mm T8, a única tolerância de espessura de parede aplicável é o desvio permitido em qualquer ponto, e este é 15% da espessura especificada.

COMPRIMENTO - TUBOS TREFILADOS					
Diâmetro Externo ou Largura nominal (mm)	Desvio permitido em relação ao comprimento nominal (somente a mais, mm)				
	Comprimento nominal (mm)			Roos	
	até 3.660	3.661 a 9.150	9.151 a 15.150	até 30 m	30 a 75 m
Até 6,34	6,4	9,5	12,7	5%	+_10%
6,35 a 31,74	3,2	6,4	9,5	5%	+_10%
31,75 a 76,19	3,2	6,4	9,5	--	--
76,20 a 203,20	4,8	7,9	11,1	--	--

RETILINEARIDADE - TUBOS TREFILADOS	
Diâmetro externo ou largura nominal (mm)	Desvio permitido por metro de comprimento (1) (2) (mm)
Abaixo de 9,52	38,75
9,53 a 152,39	0,78
152,40 e acima	1,55

1. Não aplicável em têmperas 0.
2. Não aplicável para comprimentos abaixo de 3 metros.

CÓDIGO CDA	CÓDIGO EQUIVALÊNCIA	PESO (KG/M)	DESCRIPTIVO	PÁG.
25-301		0.347	Folha	16.002
25-308		0.459	Coluna	16.001
25-311		0.336	Marco	16.001
25-312		0.336	Marco	16.001
25-315		0.434	Folha	16.002
42-032		1.356	Folha	12.005
42-035		1.156	Folha	12.005
42-061		1.135	Folha	12.003
42-062		1.292	Folha	12.004
42-063		1.292	Folha	12.004
A-025	FC-007	2.062	Coluna	18.003
A-026	30-009	0.706	Folha	11.004
A-030	30-004	0.564	Folha	11.004
A-041	30-014	0.732	Folha	11.007
A-046		0.937	Folha	11.007
A-048	25-502	0.671	Folha	9.004
A-055	25-012	0.463	Folha	9.006
A-056	25-017	0.373	Folha	9.011
A-058		0.200	Diversos	27.001
A-072	FC-012	1.269	Coluna	18.001
A-081	30-028	1.163	Folha	11.005
A-082	DC-008	1.505	Brise	24.001
A-096	FC-017	1.860	Coluna	18.002
A-101	30-044	0.223	Trilho	21.005
A-103	42-006	1.577	Folha	12.002
A-104		0.878	Folha	12.003
A-144	30-077	0.766	Folha	11.009
A-176	28-010	0.470	Folha	10.005
A-194	25-679	0.653	Folha	9.006
A-204	25-334	0.444	Folha	9.007
A-206		0.404	Folha	9.011
A-207	25-333	0.598	Folha	9.008
A-209	30-270	0.463	Complemento	11.012
A-213	30-245	0.263	Trilho	21.005
A-246	ALG-07026	0.520	Montante Mão de Amigo	29.039
A-251	ALG-07226	0.436	Montante Folha	29.042
A-252	ALG-07426	0.501	Montante Folha	29.042
A-253		0.538	Travessa Folha	29.041
A-254	ALG-06926	0.574	Montante Mão de Amigo	29.039
A-273	ALG-05626	0.538	Montante Mão de Amigo	29.037
A-279	ALG-05726	0.628	Montante Mão de Amigo	29.038
A-282	ALG-03926	0.522	Montante Lateral	29.029
A-283	ALG-22526	0.987	Travessa Inferior Folha	29.028
A-284	ALG-06826	0.533	Montante Lateral	29.039
A-285	ALG-05526	0.543	Montante Lateral	29.036
ALG-00601	BK-5058	0.274	Complemento	29.052
ALG-01001	BK-5051	0.799	Marco Inferior	29.049
ALG-01002	BK-5054	1.070	Marco Inferior	29.050

CÓDIGO CDA	CÓDIGO EQUIVALÊNCIA	PESO (KG/M)	DESCRIPTIVO	PÁG.
ALG-01101		0.814	Trilho Individual	30.001
ALG-01102	BK-5059	0.843	Marco Superior	29.049
ALG-01103	BK-5053	1.109	Marco Superior	29.050
ALG-01301		0.625	Mata-Junta	30.005
ALG-01302	BK-5052	0.474	Marco Lateral	29.051
ALG-01303	BK-5055	0.630	Marco Lateral	29.051
ALG-02426	SU-024	1.023	Marco Superior	29.014
ALG-02526	SU-025	0.973	Marco Inferior	29.014
ALG-030		1.807	Marco Inferior	30.010
ALG-04601	BK-5056	0.610	Marco	29.052
ALG-050		0,824	Caixa do Recolhedor	29.027
ALG-06126	SU-061	1.052	Montante Mão de Amigo	29.037
ALG-09026	SU-090	0.380	Folha Max	29.046
ALG-09126	SU-091	0.331	Folha Max	29.046
ALG-1000		0,573	Marco	28.011 29.016
ALG-1001		0,747	Marco Superior	28.010 29.015
ALG-1002		0,773	Marco Intermediário	29.015
ALG-1003		0,993	Marco Inferior	29.016
ALG-1004		0,906	Marco Lateral	28.012 29.026
ALG-1005		0,577	Guia da Persiana	28.017 29.026
ALG-1006		0,937	Tampa Interna	28.014 29.017
ALG-1007		0,867	Tampa Externa	28.013 29.022
ALG-1008		0,866	Guia Central	28.017 29.026
ALG-1009		1,260	Tampa Interna	28.016 29.020
ALG-1010		1,080	Tampa Externa	28.013 29.022
ALG-1011		1,014	Marco Lateral	28.012
ALG-1012		0,719	Marco	28.011
ALG-1041		0,949	Tampa Interna	28.014 29.017
ALG-1042		1,967	Tampa Interna	28.015 29.019
ALG-1043		1,159	Marco Intermediário Reforçado	29.015
ALG-1051		1,137	Tampa Interna	29.018
ALG-1052		1,388	Tampa Interna	29.021
ALG-130		1,463	Tampa Interna	30.012 29.025
ALG-18826	SU-188	0.598	Travessa Central Folha	29.035
ALG-200		0,623	Marco Intermediário	30.011 29.023

CÓDIGO CDA	CÓDIGO EQUIVALÊNCIA	PESO (KG/M)	DESCRIPTIVO	PÁG.	CÓDIGO CDA	CÓDIGO EQUIVALÊNCIA	PESO (KG/M)	DESCRIPTIVO	PÁG.
ALG-2000		1.957	Coluna Central	35.004	ALG-2051		4.599	Ancoragem Central	35.040
ALG-2001		1.940	Luva Central	35.033	ALG-2052		2.828	Coluna de Canto	35.010
ALG-2002		1.334	Coluna Lateral	35.020	ALG-2053		2.832	Luva Canto	35.035
ALG-2004		0.980	Coluna	35.001	ALG-2057		0.150	Presilha	35.043
ALG-2005		1.894	Complemento Col. Canto	35.013	ALG-2058		0.429	Arremate Coluna	35.042
ALG-2006		1.397	Coluna de Canto	35.008	ALG-2059		0.569	Arremate Peitoril	35.041
ALG-2008		0.794	Marco	35.015	ALG-2061		0.117	Tampa do Arremate Peitoril	35.041
ALG-2009		0.738	Luva para Travessa	35.031	ALG-2064		0.374	Presilha de Apoio	35.041
ALG-20101		2.045	Marco Intermediário Bandeira	30.003	ALG-2065		0.242	Arruela Dentada	35.043
ALG-2011		0.958	Travessa	35.022	ALG-2066		5.486	Ancoragem	35.039
ALG-2012		0.892	Travessa	35.026	ALG-2070		8.323	Coluna Central	35.007
ALG-2013		0.634	Folha	35.027	ALG-2073		3.709	Ancoragem	35.038
ALG-2014		0.794	Folha	35.027	ALG-2100		1.027	Coluna	35.001
ALG-2015		0.466	Folha	35.028	ALG-22626	SU-226	1.010	Travessa Inferior Folha	29.035
ALG-2016		0.612	Folha	35.027	ALG-230		1.720	Tampa Interna	30.012
ALG-2017		0.766	Folha	35.027	ALG-23026	SU-230	0.954	Marco Inferior	29.007
ALG-2018		0.194	Presilha do Quadro Fixo	35.041	ALG-23126	SU-231	0.807	Marco Inferior	29.008
ALG-2019		0.361	Arremate do Peitoril	35.041	ALG-23826	SU-238	0.714	Montante Lateral	29.038
ALG-2020		0.431	Arremate	35.042	ALG-24226	SU-242	0.746	Montante Mão de Amigo	29.034
ALG-2021		0.575	Arremate Entre Coluna	35.043	ALG-24326	SU-243	0.716	Montante Mão de Amigo	29.034
ALG-2022		0.918	Marco	35.015	ALG-24526	SU-245	0.626	Montante Lateral	29.033
ALG-2024	CX-369	1.471	Coluna Central	35.002	ALG-27026		0.749	Montante Lateral	29.036
ALG-2025		1.089	Coluna Lateral	35.016	ALG-27126	SU-271	0.347	Trilho Individual	29.009
ALG-2026		0.759	Folha Fixa	35.028	ALG-29126	SU-291	0.263	Mata Junta	29.004
ALG-2027		0.917	Folha Móvel	35.028	ALG-3006		0.650	Travessa Folha	30.015
ALG-2028		2.132	Brise Decorativo	35.025	ALG-3007		1.163	Travessa Inferior Folha	30.015
ALG-2029		1.658	Travessa para Brise Decorativo	35.023	ALG-3008		1.458	Marco Superior	30.008
ALG-2030		0.718	Luva Para Travessa	35.031	ALG-3009		1.004	Marco Travessa	30.009
ALG-2031		1.694	Luva de Brise	35.025	ALG-3010		0.887	Marco Lateral	30.009
ALG-2032		1.982	Coluna Em Ângulo	35.014	ALG-3011		0.379	Arremate	7.002
ALG-20326	SU-203	0.133	Baguete	29.048	ALG-3012		0.387	Contramarco	5.002
ALG-2033		1.914	Luva para Coluna Em Ângulo	35.036	ALG-3014		1.726	Montante Central	30.022
ALG-2034		0.892	Travessa Em Ângulo	35.022	ALG-3015		1.725	Montante Central	30.022
ALG-2035		0.713	Folha Para Veneziana	35.030	ALG-3016		0.341	Mata-Junta	30.029
ALG-2036		0.324	Veneziana	35.030	ALG-3017		1.212	Montante Central	30.018
ALG-2037		0.709	Folha	35.028	ALG-3020		1.177	Montante Central	30.018
ALG-2040		2.179	Coluna Central	35.005	ALG-3023		0.769	Mata-Junta Porta Embutida	30.029
ALG-20401		1.370	Travessa Central Folha	30.016	ALG-3024		1.243	Marco Inferior	30.002
ALG-20402		1.540	Travessa Central Folha	30.016	ALG-3025		1.545	Marco Inferior	30.008
ALG-2041		1.446	Coluna Lateral	35.021	ALG-3027		0.140	Baguete	30.030
ALG-2042		2.296	Luva Central	35.034	ALG-3028		0.433	Mata-Junta	30.005
ALG-2043		1.334	Luva Central	35.031	ALG-3042		1.099	Folha	30.028
ALG-2045		1.688	Coluna Central	35.002	ALG-3043		0.807	Folha	30.028
ALG-2046		1.656	Luva Central	35.032	ALG-3048		0.909	Montante Mão de Amigo	30.017
ALG-2047		1.186	Coluna Lateral	35.016	ALG-3049		0.873	Montante Mão de Amigo	30.017
ALG-2048		1.903	Coluna Central	35.003	ALG-3050		0.927	Montante Central	30.019
ALG-2049		1.994	Luva Central	35.032	ALG-3051		0.906	Montante Central	30.019
ALG-2050		1.294	Coluna Lateral	35.019	ALG-3052		1.698	Montante Mão de Amigo	30.026

CÓDIGO CDA	CÓDIGO EQUIVALÊNCIA	PESO (KG/M)	DESCRIPTIVO	PÁG.
ALG-3056		0.659	Marco	30.028
ALG-3058		0.744	Travessa Folha	30.028
ALG-3061		0.316	Trilho Individual	30.002
ALG-3064		1.358	Marco Lateral	30.007
ALG-3070		0.552	Folha Max	30.031
ALG-3071		0.413	Folha Max	30.031
ALG-3072		0.279	Inversor	30.031
ALG-3141		0.834	Montante	30.027
ALG-3142		0.413	Complemento	30.027
ALG-3158		0.996	Marco Travessa	30.006
ALG-3304		0.953	Marco Lateral	30.005
ALG-3305		0.207	Tampa	30.007
ALG-3311		0.795	Montante Lateral	30.017
ALG-3317		0.756	Travessa Central Folha	30.015
ALG-3328		0.172	Baguete	30.030
ALG-3343		1.718	Marco Superior	30.006
ALG-3364		1.523	Marco Inferior	30.006
ALG-382		1.069	Montante Lateral	29.032
ALG-400		0.168	Complemento	29.027
ALG-4002		0.601	Marco Lateral Liso	30.005
ALG-4003		0.708	Marco Travessa	30.002
ALG-4004		2.113	Marco Intermediário Bandeira	30.003
ALG-4005		2.113	Marco Intermediário Peitoril	30.004
ALG-4014		1.782	Montante Central	30.023
ALG-4015		1.780	Montante Central	30.023
ALG-4028		0.433	Mata-Junta	30.027
ALG-40301	ALG-1012	1.091	Montante Lateral	29.036
ALG-40302		1.843	Montante Central	30.021
ALG-40303		1.768	Montante Central	30.021
ALG-40304		1.194	Montante Lateral	30.018
ALG-40401	ALG-1011	1.097	Montante Mão de Amigo	29.037
ALG-40402		1.518	Montante Mão de Amigo	30.025
ALG-4051		0.900	Montante Central	30.019
ALG-4052		1.780	Montante Mão de Amigo	30.024
ALG-47601		1.011	Folha	35.029
ALG-47602		0.805	Folha	35.029
ALG-47603		0,836	Folha VHB	35.029
ALG-47604		0,803	Folha SSG	35.029
ALG-5015		0.143	Baguete	30.030
ALG-5052		2.299	Montante Mão de Amigo	30.025
ALG-510		0.843	Tubo Recolhedor	30.014
ALG-710		1.081	Montante Lateral	30.017
ALG-76301		1.313	Coluna	30.004
ALG-76302		1.892	Meia Coluna	35.018
ALG-76305		2.361	Coluna de Canto	35.011
ALG-76306		1.566	Coluna Lateral	35.017
ALG-76307		3.241	Coluna de Canto	35.012
ALG-76401		3.571	Coluna Central	35.006

CÓDIGO CDA	CÓDIGO EQUIVALÊNCIA	PESO (KG/M)	DESCRIPTIVO	PÁG.
ALG-8000		2.314	Coluna	36.009
ALG-8001		1.818	Travessa	36.010
ALG-8002		0.499	Contra Tampa	36.009
ALG-8003		1.948	Brise	36.010
ALG-8004		1.860	Coluna	36.009
ALG-8005		1.114	Coluna	36.007
ALG-810		0.104	Baguete	29.047
ALG-84701		1.535	Luva Lateral	35.037
ALG-86601	BK-5057	0.095	Complemento	29.052
ALG-894		2.227	Coluna de Canto	35.009
ALG-895		0.108	Baguete	29.047
ALG-896		1.098	Montante Lateral	29.031
ALG-897		0.342	Folha	28.022
ALG-898		0.520	Coluna	28.021
ALG-899		0.251	Folha	28.026
ALG-921		0.677	Marco Intermediário	28.010
ALG-922		0.861	Marco Inferior	28.010
ALG-930		1,340	Tampa Externa	29.025
ALG-936		0.525	Travessa	28.021
ALG-940	MN-049	1.312	Marco Intermediário	17.001 29.024 30.011
ALG-941		0.132	Baguete	28.027
ALG-942		0.292	Marco Perimetral	28.021
ALG-943		0.143	Pingadeira	28.022
ALG-944		0.354	Folha	28.022
ALG-945		0.401	Folha	28.021
ALG-962		0.528	Marco	28.023
ALG-963		0.615	Folha	28.024
ALG-964		0.276	Mata-Junta	28.024
ALG-965		1.020	Travessa Inferior	28.024
ALG-966		0.650	Travessa	28.023
ALG-967		0.589	Folha	28.023
ALG-968		0.203	Folha	28.025
ALG-969		0.196	Folha	28.026
ALG-970		0.252	Travessa	28.025
ALG-971		0.204	Folha	28.026
ALG-972		0.225	Folha	28.026
ALG-987		0.707	Travessa Peitoril	28.002
ALG-988		0.775	Travessa da Bandeira	28.002
ALG-989		0.308	Marco Superior	28.001
ALG-992		0.280	Veneziana	28.027
ALG-995		0.520	Veneziana	28.027
AP-417		6.593	Coxim	39.001
AP-474		2.144	Peça Para Indústria Automotiva	39.001
B-052	ALG-04926	1.024	Montante Mão de Amigo	29.031
B-058	ALG-04726	0.980	Montante Mão de Amigo	29.031
B-077	ALG-04426	0.837	Montante Lateral	29.033



CÓDIGO CDA	CÓDIGO EQUIVALÊNCIA	PESO (KG/M)	DESCRIPTIVO	PÁG.	CÓDIGO CDA	CÓDIGO EQUIVALÊNCIA	PESO (KG/M)	DESCRIPTIVO	PÁG.
B-078	ALG-06026	0.965	Montante Lateral	29.037	CX-3033		0.533	Marco Superior	28.002
B-113		0.961	Montante Central	29.033	CX-3034		0.542	Marco Inferior	28.002
BAR-4037	CL-010	0.382	Cunha	6.001	CX-3035		0.367	Marco Lateral	28.005
BAR-4157	CL-011	0.138	Cunha	6.002	CX-3036		1.022	Marco Intermediário Peitoril	29.002
BG-013		0.122	Baguete	26.003	CX-306	PC-027	0.786	Folha	21.001
BG-035		0.118	Baguete	16.002	CX-3069		0.547	Apoio Vidro	20.004
BG-202		0.113	Baguete	14.010	CX-307		0.762	Lambri	23.002
BK-486		3.293	Equipamento - Prensas	41.001	CX-3073		0.148	Veneziana	22.005
BK-5042		0.405	Dissipador	40.001	CX-308	ALG-18626	0.507	Travessa Folha	29.035
BK-5043		0.365	Dissipador	40.001	CX-3086		1.458	Trilho Superior	21.004
BK-5073		0.528	Dissipador	40.001	CX-3089		0.457	Marco Inferior	29.009
BL-5072		0.281	Dissipador	40.001	CX-309	ALG-20026	0.422	Folha Max	29.045
BR-74601		0.587	Suporte da Veneziana (Brise) - La Brise	24.003	CX-3090		0.668	Folha	29.041
BR-74602		0.695	Suporte da Veneziana (Brise) - La Brise	24.003	CX-3095		0.895	Montante Central	30.019
BR-75301		0.402	Suporte do Brise - La Brise	24.003	CX-3096		0.148	Baguete	30.030
BR-75302		0.872	Suporte do Brise - La Brise	24.004	CX-3106	CG-145	0.670	Corrimão	20.003
BR-75901		0.272	Veneziana	22.005	CX-3114		0.271	Mata Junta	29.038
BR-75902		0.264	Veneziana	22.005	CX-3116		1.420	Travessa	35.024
BR-75903		0.655	Veneziana	24.004	CX-3117		0.963	Travessa	35.024
BX-056		0.218	Liso - Guia	25.001	CX-3118		0.372	Tampa da Travessa	35.024
BX-057		0.254	Liso - Travessa	25.003	CX-314		0.710	Montante Lateral	29.029
BX-090		0.290	Frisado - Travessa	25.005	CX-315	ALG-18726	0.472	Travessa da Folha	29.039
BX-096		0,183	Baguete	25.009	CX-3153		0,777	Arremate	35.042
BX-097		0.490	Frisado - Trilho Superior	25.004	CX-316		0.620	Folha	29.041
BX-103		0.155	Liso - Folha	25.003	CX-3161		0.437	Marco	29.043
BX-123		0.204	Liso - Folha	25.002	CX-318		0.585	Marco	29.041
BX-137		0.162	Liso - Folha	25.003	CX-320	ALG-22826	0.667	Marco Inferior	29.002
BX-150		0.745	Temperado - Guia Inferior	25.008	CX-3205		1.068	Folha	12.003
BX-2000		0.652	Temperado - Trilho Superior	25.006	CX-321		1.686	Montante Central	30.020
CG-074		0.266	Tampa	20.004	CX-3217	CX-3217	0.481	Folha Max	29.046
CG-075		0.520	Jota	20.005	CX-3218		0.362	Marco	29.043
CG-077		0.843	Montante	20.006	CX-3219		0.207	Arremate	7.002
CG-078		0.493	Corrimão	20.003	CX-322	ALG-3346	0.550	Marco	30.029
CG-079		0.330	Travessa	20.004	CX-3220		0.757	Veneziana	22.006
CG-083		1.403	Corrimão	20.001	CX-323		1.577	Montante Central	30.020
CG-143		1.948	Corrimão	20.001	CX-324		0.524	Montante Central	29.029
CL-058		0.830	Temperado - Trilho Superior	25.006	CX-3244		1.551	Lambri	23.003
CL-061		0.455	Temperado - Guia Inferior	25.008	CX-3245		1.697	Lambri	23.003
CM-098		0.384	Contramarco - Porta	5.005	CX-3247		1.611	Brise	35.026
CM-1002	CM-060	0.271	Contramarco	5.005	CX-3248		2.191	Travessa para Brise Decorativo	35.023
CM-103		0.291	Contramarco	5.007	CX-3257		0.432	Tubo	27.001
CM-168		0.957	Contramarco	5.004	CX-3258		1.536	Lambri	23.004
CM-169		0.383	Arremate - Soleira	7.004	CX-3273		0.352	Contramarco	5.003
CM-173		0.509	Contramarco	5.004	CX-3274		0.166	Contramarco	5.006
CO-71601		0.167	Arremate	7.001	CX-3275		0.184	Veneziana	22.004
CO-71602		0.202	Arremate	7.001	CX-3276		0.434	Veneziana	22.003
					CX-3282		1.356	Lambri	24.005
					CX-3283		1.438	Lambri	24.005

CÓDIGO CDA	CÓDIGO EQUIVALÊNCIA	PESO (KG/M)	DESCRIPTIVO	PÁG.	CÓDIGO CDA	CÓDIGO EQUIVALÊNCIA	PESO (KG/M)	DESCRIPTIVO	PÁG.
CX-3284		1.248	Travessa	20.004	DV-101	DV-055	0.636	Divisória	26.002
CX-3288		0.640	Arremate	20.008	DV-111		0.188	Divisória	26.001
CX-3289		0.544	Contramarco	5.003	DV-113		0.252	Palheta	26.002
CX-329	FC-687	0.462	Pingadeira	19.004	DV-129		0.405	Divisória	26.001
CX-336	ALG-3021	1.724	Montante Mão de Amigo	30.026	DV-132		0.254	Travessa	26.001
CX-337	ALG-4021	1.720	Montante Mão de Amigo	30.024	DV-208		0.316	Batente	26.002
CX-496		4.398	Chassi	39.002	DV-300		1.243	Divisória ( Sanitária )	26.005
CX-497		0.256	Temperado - Capa do Trilho	25.007	DV-405		0.329	Puxador Para Móveis	26.001
CX-504	ALG-3057	0.168	Baguete	30.030	DV-406		0.533	Puxador Para Móveis	26.001
CX-505	ALG-3301	1.244	Marco Superior	30.001	DV-436		0.362	Divisória	26.002
CX-506	ALG-3306	1.138	Marco Inferior	30.001	DV-444		0.695	Rodapé	26.003
CX-531		0.149	Base de Articulação	27.001	DV-459		0.900	Batente	26.004
CX-557		0.872	Montante Lateral	29.033	DV-460		1.469	Guia de Teto	26.004
CX-559	BX-095	0.601	Liso - Trilho Superior	25.001	DV-461		1.835	Coluna Quadrada	26.005
CX-607	ALG-29226	0.218	Inversor para Baguete	29.047	E-029		0.630	Luminosos	42.001
CX-608	ALG-640	1.065	Montante Mão de Amigo	29.032	E-117		0.320	Liso - Guia Inferior	25.001
CX-609	ALG-740	1.071	Montante Mão de Amigo	29.032	E-150	30-019	0.298	Mata Junta	11.012
CX-633	ALG-06426	1.105	Montante Lateral	29.036	E-201		1.036	Luminosos	42.001
CX-640		0.990	Arremate	7.005	E-202		1.030	Luminosos	42.001
CX-641		0.667	Arremate	7.005	E-252		0.151	Vitrine	43.001
D-053	DC-004	1.233	Brise	24.002	E-256	BX-175	0.323	Frisado - Guia Inferior	25.004
D-054	DC-006	0.834	Brise	24.002	E-277	25-514	0.491	Marco Lateral	9.002
D-055	CG-012	0.504	Tubo	20.008	E-287	42-001	1.032	Marco Trilho Individual	12.001
D-056	CG-024	0.322	Tubo	2.008	E-290	E-482	0.853	Marco Superior	9.001
D-056	CG-024	0.322	Tubo	20.007	E-306	BX-240	0.484	Temperado - Guia Inferior	25.008
D-059		0.813	Brise	24.002	E-363	PC-001	1.046	Trilho Superior	21.003
D-069	PC-003	1.043	Folha	21.002	E-364	PC-006	0.426	Trilho Inferior Individual	21.004
D-070	CG-022	0.247	Tubo	20.007	E-365	PC-005	0.669	Trilho Inferior	21.004
D-072	DC-032	1.318	Brise	24.001	E-386	20-197	0.602	Marco Trilho	10.001
D-078	PC-004	0.748	Folha	21.002	E-463		0.225	Vitrine	43.001
D-079	PC-002	0.604	Folha	21.002	E-492	30-261	1.433	Marco Trilho	11.002
D-081	CG-243	0.571	Tubo	20.008	E-494	CM-126	0.450	Contramarco	5.001
D-082	CG-021	0.321	Tubo	20.007	E-495	CM-125	0.452	Contramarco	5.001
D-095	CG-003	0.436	Corrimão	20.003	E-504	CM-111	0.172	Arremate	7.003
D-102	PC-102	0.587	Folha	21.002	E-512		0.434	Capa do Trilho	25.007
D-103	CG-104	0.780	Tubo	20.008	E-517		0.502	Contramarco	5.002
D-143	CG-072	1.216	Corrimão	20.002	E-565	ALG-00226	0.700	Marco Inferior	29.001
D-185		0.374	Tubo	20.007 29.040	E-566	ALG-00126	0.760	Marco Superior	29.001
D-198		0.870	Linha Gradil	20.006	E-567	ALG-00326	0.508	Marco Lateral	29.004
D-199		0.820	Montante	20.006	E-568	ALG-00826	0.245	Mata-Junta	29.004
D-201		1.891	Linha Gradil	20.002	E-571	ALG-01026	1.024	Marco Superior	29.007
DS-036		0.151	Diversos	27.001	E-572	ALG-01126	0.941	Marco Inferior	29.007
DS-238		0.485	Tubo Recolhedor	17.006 28.017 29.027	E-573	ALG-01326	0.698	Marco Lateral	29.009
DS-314		0.639	Trilho Superior	21.003	E-574	ALG-01426	0.674	Marco Lateral	29.009
DV-055		0.276	Divisória	26.001	E-578		0.704	Marco Inferior	29.003
					E-601	ALG-02726	0.823	Marco Inferior	29.005
					E-602	ALG-02626	0.875	Marco Superior	29.005
					E-603	ALG-03226	1.195	Marco Inferior	29.010

CÓDIGO CDA	CÓDIGO EQUIVALÊNCIA	PESO (KG/M)	DESCRIPTIVO	PÁG.	CÓDIGO CDA	CÓDIGO EQUIVALÊNCIA	PESO (KG/M)	DESCRIPTIVO	PÁG.
E-604	ALG-03126	1.279	Marco Superior	29.010	L-519	30-034	0.295	Mata Junta	11.008
E-613	CM-130	0.161	Arremate	7.003	L-521	42-014	0.368	Mata Junta	12.005
E-645	ALG-12126	1.569	Marco Superior	29.012	L-537	BX-239	1.274	Temperado - Trilho Superior	25.006
E-646	ALG-12226	1.509	Marco Inferior	29.012	L-579	CL-044	1.014	Conexão	6.001
E-647	ALG-12326	0.921	Marco Lateral	29.013	L-631	DS-143	0.235	Diversos	27.002
EE-465		2.469	Dissipador	40.002	L-715	25-548	0.282	Mata Junta	9.007
EE-466		2.301	Dissipador	40.002	L-794		0.143	Pingadeira	29.044
FC-085		0.258	Tampa	19.008	L-795	ALG-08426	0.125	Pingadeira Folha Max	29.046
FC-087		1.021	Rufo	19.010	L-797	ALG-10826	0.124	Complemento Veneziana	29.048
FC-088		0.844	Rufo	19.010	L-809	CG-101	0.510	Jota	20.005
FC-124		3.526	Coluna	18.004	LB-038	U-1040	0.996	Lambri	23.002
FC-202	FC-202	1.798	Coluna	19.001	LC-015		2.186	Montante Canto 90°	37.006
FC-222		0.789	Batedeira	19.007	LC-016		2.437	Montante Canto 90°	37.008
FC-225		0.642	Marco Max	19.004	LC-017		2.215	Montante Canto 90°	37.010
FC-226		0.748	Pingadeira	19.007	LC-018		2.497	Montante Canto 90°	37.012
FC-227		0.674	Batedeira	19.006	LC-025		1.968	Travessa Intermediaria	37.024
FC-228		0.565	Folha	19.005	LC-026		2.226	Travessa Intermediaria	37.026
FC-231	FC-231	1.077	Travessa	19.003	LC-027		1.607	Travessa Intermediaria	37.024
FC-232	FC-232	1.320	Coluna	19.003	LC-035		1.349	Travessa Inferior	37.025
FC-241	FC-241	1.807	Coluna	19.002	LC-036		1.463	Travessa Inferior	37.027
FC-243		1.057	Marco	19.004	LC-037		1.594	Travessa Inferior	37.027
FC-244	FC-244	1.786	Marco	19.001	LC-038		1.924	Travessa Inferior	37.028
FC-245		0.794	Arremate	19.008	LC-051		0.406	Complemento Travessa	37.029
FC-246		0.767	Arremate	19.009	LC-055		0.515	Tampa Lateral	37.033
FC-247		0.414	Arremate	19.009	LC-056		0.618	Tampa Lateral 125	37.033
FC-249		0.604	Pingadeira	19.006	LC-061		0.326	Arremate	37.030
FC-250		0.742	Arremate	19.008	LC-062		0.413	Arremate	37.030
FC-254		0.621	Folha	19.005	LC-063		0.237	Arremate	37.030
FC-256		0.409	Arremate	19.008	LC-064		0.215	Arremate	37.030
FC-258		0.485	Arremate	19.009	LC-065		0.150	Arremate	37.031
FC-261		0.555	Folha	19.005	LC-066		0.482	Arremate	37.031
FC-265		1.396	Meia Coluna	18.006	LC-067		0.539	Arremate	37.031
FC-293		0.645	Folha	19.005	LC-068		0.203	Tampa Arremate	37.031
FC-542		0.350	Tampa	36.001	LC-069		1.370	Arremate	37.032
FC-544	U-1312	0.366	Tampa	18.003	LC-07001		1.027	Marco Inferior	37.022
I-105	25-021	0.229	Mata Junta	9.013	LC-07002		1.145	Marco Inferior	37.022
I-122	25-019	0.458	Folha	9.006	LC-07003		1.691	Marco Inferior	37.022
I-151		0.209	Vitrine	43.001	LC-080		1.707	Travessa Inferior	37.028
I-154	BX-159	0.307	Frisado - Travessa	25.005	LC-091		1.580	Tampa	37.032
I-309	25-697	0.425	Folha	9.007	LC-115		1.931	Montante Canto 90°	37.007
L-1051		0.792	Temperado - Trilho Superior	25.006	LC-116		2.185	Montante Canto 90°	37.009
L-1468	CL-006	1.049	Conexão	6.002	LC-117		2.033	Montante Canto 90°	37.011
L-213		0.697	Arremate - Soleira	7.004	LC-118		2.303	Montante Canto 90°	37.013
L-387	CL-015	0.220	Pingadeira	9.010	LC-135		1.663	Travessa Superior	37.023
L-460		0.141	Arremate - Soleira	7.005	LC-136		1.897	Travessa Superior	37.026
L-468	CL-009	1.647	Conexão	6.001	LC-139		1.769	Travessa Superior	37.023
L-473	BG-036	0.165	Baguete	12.007	LC-204		0.798	Montante	37.001
L-516	CM-029	0.308	Arremate - Soleira	7.004	LC-214		0.172	Coluna Canto	37.016

CÓDIGO CDA	CÓDIGO EQUIVALÊNCIA	PESO (KG/M)	DESCRIPTIVO	PÁG.
LC-221		0.889	Marco Maxim-Ar	37.034
LC-234		0.953	Travessa Inferior	37.020
LC-235		1.034	Travessa Inferior	37.020
LC-251		0.383	Presilha	37.043
LC-252		0.473	Presilha	37.043
LC-254		0.491	Tampa Lateral	37.035
LC-255		0.290	Arremate	37.043
LC-26001		1.495		37.005
LC-261		0.341	Arremate	37.044
LC-26101		1.007	Montante	37.025
LC-26102		1.116	Travessa	37.018
LC-26103		1.035	Travessa	37.018
LC-262		0.366	Arremate Lateral	37.044
LC-263		0.436	Arremate Lateral	37.044
LC-264		0.998	Marco Inferior	37.021
LC-265		1.116	Marco Inferior	37.021
LC-304		0.659	Montante	37.001
LC-314		0.983	Coluna Canto	37.016
LC-334		0.967	Travessa Superior	37.017
LC-335		1.085	Travessa Superior	37.017
LC-364		0.696	Marco Superior	37.019
LC-365		0.784	Marco Superior	37.019
LC-500		6.334	Sapata	37.036
LC-501	BK-5076	4.475	Ancoragem	37.039
LC-502	BK-5077	2.007	Gancho Regulagem	37.040
LC-503	BK-5078	2.867	Apoio de Regulagem	37.037
LC-504	BK-5079	1.123	Guia Regulagem	37.040
LC-505	BK-5080	0.666	Arruela	37.040
LC-506	BK-5081	2.826	Apoio de Regulagem	37.037
LC-507	BK-5082	3.725	Extensor Horizontal	37.040
LC-508		4.036	Sapata Frente de Pilar	37.036
LC-509		2.876	Apoio de Regulagem	37.038
LC-510		2.619	Ancoragem	37.039
LC-512		3.352	Ancoragem	37.042
LC-513		2.399	Apoio de Regulagem	37.038
LC-520		1.194	Barra Ligação	37.041
LC-521		1.694	Barra Ligação	37.041
LC-522		1.035	Barra Ligação	37.041
LC-523		2.071	Barra Ligação	37.041
LC-530		0.396	Trava	37.042
LC-71001		0.366	Arremate	37.045
LC-71601		0.446	Arremate	37.045
LC-71801		0.435	Arremate	37.046
LC-71802		0.604	Arremate	37.046
LC-72801	LC-056	0.226	Pingadeira	37.035
LC-76501		1.609	Montante	37.004
LC-76502		1.525	Montante	37.004
LC-76503		1.948	Montante Canto	37.014

CÓDIGO CDA	CÓDIGO EQUIVALÊNCIA	PESO (KG/M)	DESCRIPTIVO	PÁG.
LC-76504		2.333	Montante Canto	37.015
LC-76505		1.570	Montante	37.002
LC-76506	LC-006	1.735	Montante	37.003
LC-76515		1.309	Montante	37.002
LC-76516	LC-106	1.486	Montante	37.003
LC-79801		0.297	Complemento Travessa	37.029
LC-80801		1.092	Complemento Travessa	37.029
LC-82101		0.286	Complemento da Travessa	37.047
LC-82102		0.430	Complemento	37.046
LC-83101		1.122	Ancoragem	37.042
LC-85801		0.356	Complemento	37.047
LC-85802		0.501	Complemento	37.047
MA-0011		1.033	Marco	32.001
MA-03602		1.204	Marco	32.001
MA-04601		0.701	Marco	32.002
MA-09601		1.026	Marco	32.002
MA-09602		0.989	Marco	32.003
MA-1011		1.230	Folha	32.005
MA-22401		1.141	Travessa	32.006
MA-3001		0.187	Arremate	32.007
MA-42602		1.230	Folha	32.003
MA-42603		1.196	Folha	32.004
MA-44601		0.927	Folha	32.004
MA-49601		0.813	Folha	32.005
MA-6001		0.231	Arremate Inferior	32.007
MA-70602		0.133	Arremate	32.007
MA-73001		0.447	Soleira	32.007
MA-79801		0.374	Tampa	32.007
MA-82001		0.236	Arremate Inferior	32.007
MA-82401		0.815	Complemento	32.006
MB-009		0.175	Mata Junta	13.001
MB-011		0.341	Folha	13.001
MD-01601		2.359	Marco	33.001
MD-20001		0.881	Travessa Inferior	33.002
MD-40301		1.491	Folha Lateral	33.002
MD-40302		1.624	Marco de Giro	33.001
MD-40601		0.431	Montante Folha	33.003
MD-78501		0.618	Mata-Junta Lateral	33.003
MD-79601		0.661	Tampa Contorno	33.003
MD-81001		0.446	Trilho	33.003
ME-011		0.887	Marco Superior	15.001
ME-013		0.236	Arremate - Soleira	7.004
ME-056		0.197	Pingadeira	16.001
ME-071		0.368	Folha	15.001
ME-072		0.336	Folha	15.001
ME-075		0.763	Folha	15.002
ME-078		1.128	Folha	15.002
ME-092		0.160	Arremate	7.001

CÓDIGO CDA	CÓDIGO EQUIVALÊNCIA	PESO (KG/M)	DESCRIPTIVO	PÁG.	CÓDIGO CDA	CÓDIGO EQUIVALÊNCIA	PESO (KG/M)	DESCRIPTIVO	PÁG.
ME-178		0.532	Folha	15.001	MO-038		0.848	Apoio do Vidro	38.007
MM-375		0.417	Folha	16.002	MO-040	IF-040	0.332	Barrote Trapezoidal	38.008
MM-376		0.500	Coluna	16.001	MO-055	IF-055	1.126	Pontaleta	38.010
MN-001		1.377	Marco Superior	17.001	MO-056	IF-056	1.296	Pontaleta	38.010
				29.023	MO-500	CX-3209	3.479	Ancoragem	38.009
				30.010	MO-501	CX-3208	1.505	Ancoragem	38.009
MN-003		1.091	Marco	17.002	MO-74901		0.795	Luva	38.008
				29.024	MO-77101		1.678	Corrimão	38.003
				30.011	MO-77102		1.844	Corrimão	38.004
MN-004		0.176	Remate	17.003	MP-073		0.105	Porta Palheta	14.011
				30.014	MP-300		0.361	Folha	14.009
MN-007		0.710	Guia Persiana	17.003	MP-302		0.442	Folha	14.010
				29.026	MP-303		0.450	Folha	14.011
				30.014	MP-305		0.368	Folha	14.011
MN-010		1.495	Marco Inferior	17.002	MP-309		0.426	Folha	14.008
				29.024	MP-321		0.468	Folha	14.010
MN-015		0.843	Tubo Recolhedor	17.006	MP-332		0.580	Folha	14.008
				29.027	MP-336		0.463	Folha	14.010
MN-023		0.688	Marco Intermediário	17.001	MP-344		0.947	Marco Trilho Superior	14.002
				29.023	MP-345		0.710	Marco	14.005
MN-031		1.396	Tampa Interna	17.004	MP-347		0.197	Arremate	7.001
MN-039		1.348	Tampa Externa	17.005	MP-352		0.200	Mata Junta	14.005
				30.013	MP-354		0.983	Folha	14.008
MN-049	ALG-940	1.312	Marco Intermediário	17.001	MP-357		0.570	Marco Trilho Superior	14.001
MN-050		0.738	Caixa do Recolhedor	17.003	MP-360		0.442	Marco	14.004
				29.027	MP-361		1.087	Marco Trilho Intermediário Superior	14.003
				30.014	MP-363		0.542	Marco Travessa	14.003
MN-055		0.376	Terminal	17.003	MP-366		0.877	Marco Trilho Superior	14.006
				28.017	MP-368		0.678	Marco	14.007
				29.027	MP-369		0.583	Marco	14.007
				30.014	MP-372		0.458	Folha	14.009
MO-001	IF-001	1.422	Corrimão Vidro	38.001	MP-373		0.401	Folha	14.009
MO-002	IF-002	1.095	Corrimão	38.001	MP-374		0.577	Folha	14.009
MO-003	IF-003	1.698	Corrimão Vidro	38.001	MP-378		0.356	Folha	14.008
MO-004	IF-004	1.386	Corrimão Vidro / Barrote	38.002	MP-379		0.924	Folha	14.011
MO-005	IF-005	1.274	Corrimão Vidro / Barrote	38.002	MP-389		0.477	Marco Travessa Liso	14.004
MO-007		1.635	Corrimão Vidro	38.003	MP-395		0.528	Marco	14.007
MO-008		1.229	Corrimão Vidro	38.002	MP-397		0.379	Marco	14.004
MO-010	IF-010	0.598	Base Corrimão	38.004	MP-404		0.820	Marco Trilho Inferior	14.002
MO-020	IF-020	1.274	Montante Retangular	38.005	MP-405		1.024	Marco Trilho Intermediário Inferior	14.003
MO-021	IF-021	1.102	Montante Arredondado	38.005	MP-406		1.173	Marco	14.002
MO-022	IF-022	1.909	Montante de Canto	38.006	MP-407		1.028	Marco Trilho Inferior	14.006
MO-023		1.392	Montante Duplo	38.006	MP-409		0.793	Marco Trilho Inferior	14.001
MO-030	IF-030	0.492	Apoio Para Vidro	38.007	MP-415		0.610	Marco Trilho Inferior	14.001
MO-033		0.967	Apoio Vidro	38.007	MP-416		0.827	Marco Trilho Inferior	14.006
MO-035	IF-035	0.177	Tampa	38.008	P-064	30-051	0.398	Folha	11.011
MO-036	IF-036	0.199	Tampa	38.008					
MO-037		0.295	Tampa	38.008					

CÓDIGO CDA	CÓDIGO EQUIVALÊNCIA	PESO (KG/M)	DESCRIPTIVO	PÁG.
P-068	30-008	0.693	Folha	11.006
P-075	30-036	0.598	Coluna	11.004
P-078	30-025	0.761	Travessa	11.005
P-084	30-003	0.530	Folha	11.006
P-120	30-049	0.528	Folha	11.011
P-121	30-050	0.522	Folha	11.011
P-140	25-570	0.459	Folha	9.005
P-145	25-572	0.443	Folha	9.012
P-146	25-559	0.436	Folha	9.012
P-147	25-555	0.328	Folha	9.014
P-151	25-568	0.511	Folha	9.005
P-152	25-569	0.641	Folha	9.005
P-153	25-026	0.529	Travessa	9.009
P-155	25-522	0.542	Folha	9.010
P-161	25-004	0.479	Folha	9.011
P-165	30-030	1.171	Travessa	11.005
P-166	25-524	0.427	Folha	9.012
P-167	25-523	0.378	Folha	9.012
P-194	42-025	0.883	Travessa	12.003
P-205	28-205	0.881	Coluna	10.003
P-227	25-549	0.462	Folha	9.013
P-253	42-023	0.581	Folha	12.006
P-255	25-023	0.647	Travessa	9.009
P-258	30-067	1.159	Coluna	11.001
P-264	30-082	1.124	Folha	11.009
P-269	30-024	0.758	Travessa	11.005
P-270	30-026	0.778	Folha	11.009
P-272	30-027	0.751	Marco	11.008
P-273	30-023	0.604	Marco	11.008
P-274	FC-070	0.954	Coluna	9.002
P-278	CC-023	2.179	Coluna	12.002
P-279	42-007	1.331	Travessa	12.002
P-280	42-012	0.807	Marco	12.005
P-281	30-011	0.785	Folha	11.006
P-282	30-012	0.840	Folha	11.006
P-318	25-504	0.650	Folha	9.005
P-319	25-508	0.686	Folha	9.004
P-335	23-005	0.316	Folha	8.001
P-336		0.357	Folha	8.002
P-337	23-001	0.375	Folha	8.001
P-358	30-033	0.927	Folha	11.007
P-412	25-540	0.542	Marco	9.007
P-414	25-542	0.674	Folha	9.008
P-416	25-546	0.591	Folha	9.008
P-417	30-079	0.731	Travessa	11.008
P-418		0.739	Folha	12.006
P-419	30-235	0.753	Travessa	11.010
P-513	28-005	0.434	Folha	10.004

CÓDIGO CDA	CÓDIGO EQUIVALÊNCIA	PESO (KG/M)	DESCRIPTIVO	PÁG.
P-514	28-008	0.479	Folha	10.005
P-515	28-007	0.484	Folha	10.005
P-516	28-009	0.469	Folha	10.005
P-517	28-001	0.326	Folha	10.003
P-518	28-004	0.375	Folha	10.004
P-519	28-003	0.375	Folha	10.004
P-521	28-048	0.418	Folha	10.004
P-525		0.309	Folha	9.014
P-528	28-928	0.398	Travessa	10.006
P-530	28-012	0.538	Folha	10.006
P-570	PE-099	1.248	Coluna	9.003
P-574	25-669	0.636	Travessa	9.009
P-578		1.504	Coluna	11.002
P-629	ALG-04126	0.508	Montante Mão de Amigo	29.030
P-630	ALG-04026	0.479	Montante Mão de Amigo	29.030
P-633	ALG-22726	0.549	Travessa Central Folha	29.028
P-634	ALG-00526	0.950	Travessa Bandeira	29.002
P-636	ALG-00926	0.907	Coluna	29.003
P-637	ALG-08126	0.404	Montante / Folha	29.045
P-638	ALG-08226	0.379	Folha Max	29.045
P-639	ALG-08026	0.342	Folha Max	29.045
P-640	ALG-08626	0.589	Coluna	29.044
P-641	ALG-08526	0.497	Travessa	29.044
P-642	ALG-09626	0.314	Montante Mão de Amigo	29.040
P-643	ALG-09726	0.401	Folha	29.040
P-644	ALG-09826	0.407	Folha	29.040
P-645	ALG-07326	0.449	Travessa Folha	29.042
P-661	ALG-01926	1.748	Travessa Bandeira	29.008
P-665	ALG-04226	0.572	Montante Mão de Amigo	29.030
P-668	ALG-05026	0.870	Travessa Central Folha	29.028
P-684	ALG-05826	0.462	Montante Mão de Amigo	29.030
P-693		0.482	Folha	29.041
P-816	28-049	0.560	Marco Travessa Liso	10.002
P-818	28-057	0.525	Marco Travessa Liso	10.001
PC-010		0.987	Folha	21.001
PU-800		0.071	Perfil U	27.003
RB-003		1.971	Coluna	36.001
RB-004		2.119	Coluna	36.001
RB-006		1.778	Coluna	36.004
RB-007		2.069	Coluna	36.004
RB-011		0.359	Contra Tampa	36.001
RB-015		0.490	Contra Tampa	36.005
RB-016		0.598	Contra Tampa	36.005
RB-023		1.501	Travessa	36.002
RB-024		1.889	Travessa	36.002
RB-026		1.622	Travessa	36.006
RB-027		1.913	Travessa	36.006
RB-034		1.705	Meia Coluna	36.003



CÓDIGO CDA	CÓDIGO EQUIVALÊNCIA	PESO (KG/M)	DESCRIPTIVO	PÁG.	CÓDIGO CDA	CÓDIGO EQUIVALÊNCIA	PESO (KG/M)	DESCRIPTIVO	PÁG.
RB-041		0.495	Tampa	36.005	RE-40401		0.722	Montante	31.014
RB-042		1.066	Brise (Tampa)	36.005	RE-40402		0.944	Montante	31.015
RB-051		0.897	Folha	36.011	RE-40403		0.973	Montante	31.015
RB-052		0.897	Marco	36.011	RE-40601		0.989	Montante	31.017
RB-103		1.564	Luva	36.014	RE-70601		0.147	Baguete	31.018
RB-104		2.113	Luva	36.014	RE-72101		0.216	Pingadeira	31.018
RB-201		0.592	Folha	36.012	RE-72102		0.289	Mata Junta	31.018
RB-202		0.691		37.034	RE-78301		0.180	Mata Junta	31.017
RB-202		0.691		36.012 37.034	RE-78401		0.380	Mata Junta	31.017
RB-202		0.691			RE-78402		0.408	Mata Junta	31.017
RB-203		0.474	Folha	36.012	RE-78403		0.297	Mata Junta	31.017
RB-204		0.645	Folha	36.012	RE-79301		0.138	Tampa	31.018
RB-26401		0.645	Travessa	36.008	RE-82401		0.190	Complemento	31.018
RB-404		0.645	Tampa	36.003	RE-99701		0.447	Complemento	31.018
RB-47701		3.698	Coluna	36.007	SI-313		1.666	Montante Mão de Amigo	30.027
RB-501		0.203	Complemento	36.013	T-095		0.384	Arremate	7.002
RB-76401		2.498	Coluna	36.007	T-102		0.192	Arremate	7.002
RB-79701		0.378	Complemento	36.013	T-122	CM-007	0.157	Arremate	7.003
RB-79801		0.628	Complemento	36.013	T-124	CM-006	0.166	Arremate	7.003
RB-80801		1.006	Brise (Tampa)	36.002	T-180		0.131	Perfil T	27.002
RB-83701		1.760	Ancoragem	36.014	T-214		0.213	Perfil T	27.002
RE-01001		1.122	Marco	31.004	T-215		0.157	Perfil T	27.002 29.048
RE-01002		1.508	Marco	31.006	U-1002	BX-158	0.171	Frisado - Folha	25.005
RE-01003		2.048	Marco	31.007	U-1014	BX-241	0.256	Temperado - Folha	25.008
RE-01004		1.494	Marco	31.005	U-1015		0.197	Temperado - Folha	25.009
RE-01101		1.141	Marco	31.004	U-1076	BG-037	0.192	Baguete	12.007
RE-01102		1.527	Marco	31.006	U-1086	FC-419	0.398	Contra Tampa	18.003
RE-01103		2.041	Marco	31.007	U-1098	DS-266	0.550	Trilho Superior	21.003
RE-01104		1.486	Marco	31.005	U-1108	BX-069	0.357	Temperado - Guia	25.007
RE-01301		0.421	Marco	31.009	U-1230	ALG-10226	0.109	Baguete	29.047
RE-01302		0.602	Marco	31.009	U-1231	ALG-10326	0.141	Baguete	29.047
RE-01303		0.689	Marco	31.008	U-1233	ALG-09326	0.282	Marco	29.040
RE-01304		0.509	Marco	31.008	U-1244	BX-093	0.227	Liso - Marco	25.002
RE-01601		1.612	Marco	31.001	U-1264	ALG-10726	0.271	Vedação Montante	29.038
RE-01602		0.992	Marco	31.001	U-1319	BX-184	0.258	Temperado - Capa do Trilho	25.007
RE-01603		1.231	Marco	31.002	U-2109		0.180	Frisado - Marco	25.004
RE-01604		1.849	Marco	31.002	U-2111		0.155	Frisado - Folha	25.005
RE-01605		1.339	Marco	31.003	U-396		0.176	Liso - Folha	25.002
RE-20001		1.200	Travessa	31.010	U-397		0.713	Box - Liso	25.001
RE-20002		1.155	Travessa	31.011	U-399	BX-093	0.274	Liso - Marco	25.002
RE-20201		0.730	Travessa	31.010	U-425	25-510	0.155	Trilho	9.013
RE-20202		0.884	Travessa	31.011	U-461		0.705	Marco	11.003
RE-20401		1.054	Travessa	31.012	U-462		0.534	Marco	11.003
RE-40301		0.822	Montante	31.013	U-482	BG-010	0.113	Baguete	11.009
RE-40302		1.051	Montante	31.013	U-486		0.533	Contra Tampa	18.005
RE-40303		1.047	Montante	31.014	U-487		0.474	Tampa	18.005
RE-40304		1.151	Montante	31.016	U-491	CL-022	0.099	Temperado - Tampa	25.009
RE-40305		0.726	Montante	31.016					

CÓDIGO CDA	CÓDIGO EQUIVALÊNCIA	PESO (KG/M)	DESCRIPTIVO	PÁG.
U-495	CG-019	0.169	Tampa	20.005
U-496	CG-017	0.363	Travessa	20.005
U-522	BG-001	0.101	Baguete	26.003
U-531		0.175	Tampa	18.005
U-611	BG-021	0.209	Baguete	12.007
U-615	FC-014	0.362	Contra Tampa	18.001
U-621	FC-013	0.281	Tampa	18.001
U-653	BX-174	0.244	Frisado - Marco	25.004
U-654		0.198	Frisado - Perfil "U" - Regulagem	25.005
U-679	BG-009	0.168	Baguete	11.009
U-681	25-032	0.132	Trilho	9.013
U-683	CL-050	0.149	Guia	9.010
U-696	BG-023	0.200	Baguete	12.007
U-804	BG-006	0.100	Baguete	10.006
U-877	FC-542	0.339	Tampa	18.002
U-878	FC-543	0.371	Contra Tampa	18.002
U-900	28-514	0.225	Marco	10.006
U-992	28-051	0.214	Marco	10.004
UP-010		0.704	Folha	34.002
UP-011		1.049	Folha	34.002
UP-020		1.444	Marco	34.001
UP-021		1.263	Marco	34.001
UP-050		0.234	Mata-Junta	34.003
UP-051		0.143	Tampa Guia Lateral	34.003
UP-052		0.214	Guia Lateral	34.003
UP-060		0.191	Baguete	34.003
UP-200		0.145	Presilha	34.003
VG-030		0.438	Marco Perimetral	28.021
VG-040		0.287	Marco	28.025
VG-041		0.260	Marco	28.025
VG-150		0.610	Marco	28.023
VG-20201		0.362	Marco	28.005
VG-210		0.469	Marco Inferior	28.001
VG-211		0.511	Marco Inferior	28.003
VG-215		0.437	Marco Inferior	28.001
VG-216		0.479	Marco Inferior	28.003
VG-250		0.458	Marco Superior	28.001
VG-251		0.500	Marco Superior	28.003
VG-270		0.259	Marco Lateral	28.005
VG-271		0.349	Marco Lateral	28.004
VG-272		0.349	Marco Lateral	28.004
VG-273		0.370	Marco Lateral	28.004
VG-274		0.370	Marco Lateral	28.004
VG-310		0.614	Marco Inferior	28.006
VG-311		0.656	Marco Inferior	28.007
VG-315		0.647	Marco Inferior	28.006
VG-316		0.689	Marco Inferior	28.007

CÓDIGO CDA	CÓDIGO EQUIVALÊNCIA	PESO (KG/M)	DESCRIPTIVO	PÁG.
VG-350		0.651	Marco Superior	28.006
VG-351		0.693	Marco Superior	28.007
VG-370		0.351	Marco Lateral	28.009
VG-371		0.449	Marco Lateral	28.008
VG-372		0.532	Marco Lateral	28.008
VG-373		0.463	Marco Lateral	28.008
VG-374		0.553	Marco Lateral	28.008
VG-40301		0.312	Marco Lateral	28.005
VG-610		0.352	Folha Horizontal	28.018
VG-615		0.646	Travessa Inferior	28.018
VG-665		0.379	Folha Horizontal	28.018
VG-710		0.328	Folha Lateral	28.019
VG-711		0.341	Folha Lateral	28.019
VG-731		0.338	Folha Mão de Amigo	28.019
VG-732		0.609	Folha Mão de Amigo	28.020
VG-736		0.707	Folha Mão de Amigo	28.020
VG-737		0.737	Folha Mão de Amigo	28.020
VG-745		0.496	Folha Lateral	28.019
VG-830		0.400	Mão de Amigo	28.020
VG-950		0.149	Complemento - Porta	28.028
VG-951		0.137	Complemento - Janela	28.028
VG-970		0.161	Mata Junta	28.009
VZ-023		0.293	Veneziana	22.002
VZ-037		0.154	Veneziana	22.005
VZ-060		0.377	Veneziana	22.004
VZ-064		0.516	Veneziana	22.003
Y-1000	CM-200	0.185	Contramarco	5.006
Y-1047	CB-266	0.267	Temperado - Batedeira	25.009
Y-106	BX-007	0.310	Liso - Folha	25.003
Y-1063	CM-063	0.229	Contramarco	5.005
Y-113	30-052	0.338	Fixo	11.011
Y-1151	CM-151	0.257	Contramarco - Porta	5.005
Y-1174	CM-174	0.369	Contramarco	5.004
Y-120	25-557	0.233	Contramarco	5.006
Y-126	25-556	0.333	Marco	9.011
Y-131	30-001	0.458	Folha	11.004
Y-140	30-054	0.406	Marco	11.010
Y-148	30-056	0.330	Batedeira	11.012
Y-181		0.523	Marco	12.006
Y-195	25-565	0.474	Folha	9.004
Y-196	25-500	0.462	Folha	9.004
Y-197	25-027	0.280	Folha	9.014
Y-199		0.802	Marco	11.003
Y-200	25-554	0.257	Batedeira	9.010
Y-206	CM-004	0.280	Contramarco	5.001
Y-214	30-048	0.595	Marco	11.010
Y-215	25-561	0.534	Marco	9.009
Y-271	42-026	0.593	Fixo	12.007

CÓDIGO CDA	CÓDIGO EQUIVALÊNCIA	PESO (KG/M)	DESCRIPTIVO	PÁG.
Y-301	28-523	0.431	Marco	10.002
Y-325	28-525	0.586	Marco	10.003
Y-335	LB-036	0.789	Lambri	23.001
Y-346	30-084	0.499	Marco	11.010
Y-350	CL-016	1.046	Marco Travessa Liso	12.001
Y-351		0.439	Fixo	12.006
Y-355		0.708	Lambri	23.001
Y-418		0.279	Marco	8.001
Y-420		0.384	Fixo	8.001
Y-429	LB-050	0.624	Lambri	23.001
Y-473		0.360	Marco	8.002
Y-487	28-199	0.593	Marco	10.001
Y-625	28-006	0.385	Folha	10.004
Y-626	28-002	0.266	Folha	10.003
Y-628	28-011	0.234	Marco	10.006
Y-632	28-029	0.398	Marco	10.002
Y-687	CM-113	0.441	Contramarco	5.003
Y-689	VZ-049	0.300	Veneziana	22.004
Y-715	CM-129	0.387	Contramarco	5.002
Y-721	CM-110	0.202	Contramarco	5.006
Y-776	ALG-00726	0.357	Marco Lateral	29.004
Y-777	ALG-00426	0.475	Marco Travessa	29.001
Y-778	ALG-01226	0.508	Marco Lateral	29.009
Y-779	ALG-07926	0.333	Marco	29.043
Y-782	ALG-07126	0.279	Marco	29.042
Y-784	ALG-01826	0.658	Marco Travessa	29.008
Y-802	ALG-03026	0.802	Marco	29.044
Y-807	ALG-08826	0.292	Junção Marco	29.047
Y-829	ALG-05326	0.458	Travessa Folha	29.028
Z-063	CR-159	0.295	Baguete	21.005
Z-082		0.341	Trilho	11.013
Z-114	25-560	0.531	Marco	9.003
Z-118	30-039	0.624	Marco	11.012
Z-145	VZ-177	0.286	Veneziana	22.003
Z-148	VZ-001	0.295	Veneziana	22.002
Z-163	VZ-004	0.258	Veneziana	22.001
Z-174	25-515	0.661	Marco Inferior	9.001
Z-175	25-517	0.539	Marco Travessa Liso	9.002
Z-176	25-516	0.812	Marco Inferior	9.001
Z-181	30-089	0.561	Marco	11.001
Z-182	30-068	0.541	Marco Travessa Liso	11.001
Z-192		0.780	Marco	9.003
Z-194	VZ-005	0.352	Veneziana	22.003
Z-201S	VZ-058	0.262	Veneziana	22.001
Z-203	VZ-006	0.304	Veneziana	22.002
Z-248	VZ-047	0.271	Veneziana	22.004
Z-262	30-253	0.734	Marco	11.002
Z-265	42-002	1.048	Marco Trilho Indferior	12.001

CÓDIGO CDA	CÓDIGO EQUIVALÊNCIA	PESO (KG/M)	DESCRIPTIVO	PÁG.
Z-281	ALG-02826	0.517	Marco Lateral	29.006
Z-282	ALG-03326	0.742	Marco Lateral	29.011
Z-283	ALG-02926	0.645	Marco Travessa	29.006
Z-284	VZ-051	0.269	Veneziana	22.001
Z-524	VZ-024	0.268	Veneziana	22.001
Z-990		0.260	Veneziana	22.002

# PERFIS TABELADOS

## BARRAS CHATAS

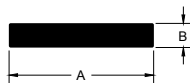

CÓDIGO		DIMENSÕES				PESO (Kg/m)
CDA	EQUIVALÊNCIA	MILÍMETROS		POLEGADAS		
		A	B	A	B	
BAR-012	BC-002	12,70	3,17	1/2	1/8	0,108
BAR-013	BC-008	15,87	3,18	5/8	1/8	0,136
BAR-049	BC-009	15,88	4,76	5/8	3/16	0,204
BAR-014	BC-015	19,05	3,18	3/4	1/8	0,164
BAR-050	BC-016	19,05	4,76	3/4	3/16	0,245
BAR-089	BC-017	19,05	6,35	3/4	1/4	0,327
BAR-015	BC-021	22,22	3,18	7/8	1/8	0,191
BAR-5008	-	22,22	7,93	7/8	-	0,477
BAR-293	BC-025	25,40	3,17	1	-	0,218
BAR-091	BC-027	25,40	6,35	1	1/4	0,437
BAR-019	BC-036	31,75	3,18	1,1/4	1/8	0,273
BAR-022	BC-050	38,10	3,17	1,1/2	1/8	0,328
BAR-057	BC-051	38,10	4,76	1,1/2	3/16	0,491
BAR-5021	-	44,45	7,93	1,3/4	-	0,955
BAR-027	BC-060	50,80	3,17	2	1/8	0,436
BAR-061	BC-061	50,80	4,76	2	3/16	0,655
BAR-6001	-	65,00	6,00	-	-	1,036
BAR-6000	BC-321	80,00	6,00	-	-	1,279

## CANTONEIRAS ABAS IGUAIS

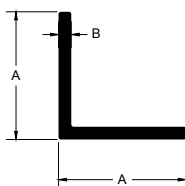

CÓDIGO		DIMENSÕES				PESO (Kg/m)
CDA	EQUIVALÊNCIA	MILÍMETROS		POLEGADAS		
		A	B	A	B	
L-002	CT-001	12,70	1,59	1/2	1/16	0,103
L-405	CT-005	15,88	1,58	5/8	1/16	0,128
L-009	CT-007	19,05	1,58	3/4	1/16	0,156
L-6000	-	25,40	1,00	1	-	0,135
L-013	CT-016	25,40	1,58	1	1/16	0,210
L-014	CT-019	25,40	3,18	1	1/8	0,409
L-5007	-	31,75	1,60	1,1/4	-	0,268
L-018	CT-022	31,75	3,18	1,1/4	1/8	0,519
L-744	CT-047	38,10	1,59	1,1/2	-	0,321
L-022	CT-026	38,10	3,17	1,1/2	1/8	0,627
L-612	CT-031	50,80	2,00	2	-	0,539
L-025	CT-032	50,80	3,18	2	1/8	0,847
L-026	CT-033	50,80	4,76	2	3/16	1,245

**CANTONEIRAS ABAS DESIGUAIS**

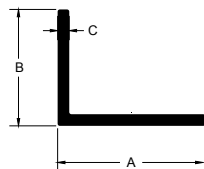

CÓDIGO		DIMENSÕES						PESO (Kg/m)
CDA	EQUIVALÊNCIA	MILÍMETROS			POLEGADAS			
		A	B	C	A	B	C	
L-093	CT-204	25,40	12,70	3,18	1	1/2	1/8	0,301
CT-209	-	32,00	16,20	1,20	-	-	-	0,140
L-6001	-	38,10	25,40	1,50	1,1/2	1	-	0,252
L-100	CT-213	38,10	25,40	3,18	1,1/2	1	1/8	0,519
L-668	CT-218	50,80	31,75	2,00	2	1,1/4	-	0,436
L-6003	-	75,00	50,00	4,76	-	1,31/32	3/16	1,550
L-6002	-	76,20	38,10	1,50	3	1,1/2	-	0,458
L-5006	CT-226	76,20	50,80	3,18	3	2	1/8	1,066
L-6004	-	101,80	50,00	4,76	-	1,31/32	3/16	1,896

**TUBOS REDONDOS**

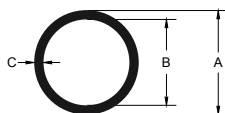

CÓDIGO		DIMENSÕES					PESO (Kg/m)
CDA	EQUIVALÊNCIA	MILÍMETROS			POLEGADAS		
		A	B	C	A	B	
TUB-003	TR-002	9,53	6,35	1,59	3/8	-	0,107
TUB-009	TR-004	12,70	10,22	1,24	1/2	-	0,121
TUB-010	TR-005	12,70	9,50	1,60	1/2	1/16	0,150
TUB-018	TR-012	15,88	13,48	1,20	-	-	0,149
TUB-019	TR-014	15,88	12,72	1,58	5/8	1/16	0,191
TUB-017	TR-890	15,88	11,88	2,00	-	-	0,126
TUB-026	-	19,00	15,00	2,00	-	-	0,153
TUB-027	TR-019	19,05	16,65	1,20	3/4	-	0,182
TUB-028	-	19,50	16,30	1,60	3/4	1/16	0,236
TUB-037	TR-033	22,23	19,83	1,20	-	-	0,214
TUB-038	TR-035	22,23	19,07	1,58	1/8	1/16	0,277
TUB-5045	-	25,00	22,60	1,20	-	-	0,244
TUB-044	TR-039	25,40	23,40	1,00	1	-	0,209
TUB-046	TR-040	25,40	22,20	1,60	1	1/16	0,322
TUB-222	-	25,40	17,40	4,00	1	-	0,397
TUB-058	TR-055	31,75	28,59	1,58	1,1/4	1/16	0,405
TUB-5041	-	36,20	22,30	6,95	-	-	1,725
TR-069	-	38,10	35,90	1,10	1,1/2	-	0,346
TUB-675	TR-070	38,10	34,92	1,59	1,1/2	-	0,493
TUB-215	TR-072	38,10	33,34	2,38	1,1/2	3/32	0,721
TUB-5039	-	42,60	28,30	7,15	-	-	2,620
TUB-5042	-	49,30	36,30	6,50	-	-	2,361
TR-098	TUB-610	50,80	47,62	1,59	2	-	0,664

# PERFIS

## TABELADOS

CÓDIGO		DIMENSÕES					PESO (Kg/m)
CDA	EQUIVALÊNCIA	MILÍMETROS			POLEGADAS		
		A	B	C	A	B	
TUB-091	TR-099	50,80	46,80	2,00	2	-	0,832
TUB-092	TR-100	50,80	44,44	3,18	2	1/8	1,290
TUB-5043	-	55,30	42,70	6,30	-	-	2,620
TUB-5036	-	64,80	46,30	9,25	-	-	4,361
TR-311	-	76,20	72,90	1,65	3	-	1,046
TUB-636	TR-135	76,20	72,20	2,00	3	-	1,271
TR-136	-	76,20	69,86	3,17	3	-	1,965
TUB-5040	-	78,50	60,30	9,10	-	-	5,376
TUB-5037	-	94,20	73,50	10,35	-	-	7,367
TUB-158	TR-362	100,00	96,00	2,00	-	-	1,668
TR-161	TUB-278	101,60	98,40	1,60	4	-	1,360
TR-162	TUB-182	101,60	96,40	2,60	4	-	2,185

### TUBOS RETANGULARES



CÓDIGO		DIMENSÕES					PESO (Kg/m)	
CDA	EQUIVALÊNCIA	MILÍMETROS			POLEGADAS			
		A	B	C	A	B		C
TUB-6002	-	25,40	12,70	1,00	1	1/2	-	0,195
TUB-4501	TG-001	25,40	12,70	1,59	1	1/2	1/16	0,300
TUB-4509	TG-002	30,00	20,00	2,00	-	-	-	0,499
TUB-6000	TG-123	38,10	25,40	1,50	1,1/8	1	-	0,498
TUB-4545	TG-003	38,10	25,40	2,00	1,1/2	1	-	0,644
TG-108	-	50,80	38,10	1,50	2	1,1/2	-	0,697
TUB-4536	TG-004	50,80	12,70	1,58	2	1/2	1/16	0,516
TUB-4576	TG-073	50,80	25,40	1,00	2	1	-	0,402
TUB-4560	TG-005	50,80	25,40	1,50	2	1	-	0,595
TUB-4504	TG-007	50,80	25,40	1,98	2	1	-	0,775
TUB-4513	TG-008	50,80	38,10	1,98	2	1,1/2	-	0,911
TUB-4543	TG-026	60,30	38,10	1,70	2,3/8	1,1/2	-	0,875
TUB-4591	-	76,20	25,40	1,85	3	1	-	0,987
TUB-6001	-	76,20	38,10	1,50	3	1,1/2	-	0,905
TUB-4517	TG-014	76,20	38,10	1,98	3	1,1/2	-	1,126
TUB-4518	-	76,20	38,10	3,00	3	1,1/2	-	1,760
TUB-4537	TG-018	101,60	38,10	2,40	4	1,1/2	-	1,756
TG-072	-	101,60	50,80	1,98	4	2	-	1,592
TUB-4530	TG-085	101,60	50,80	3,00	4	2	-	2,380
TUB-6004	-	120,00	50,00	3,00	-	1,31/32	-	2,666
TUB-4542	TG-047	125,00	80,00	2,50	5	-	-	2,709
TG-037	-	152,40	38,10	2,40	6	1,1/2	-	2,415
TUB-4520	TG-024	152,40	38,10	3,20	6	1,1/2	1/8	3,192
TUB-4559	TG-082	152,40	50,80	3,00	6	2	-	3,206



**TUBOS QUADRADOS**

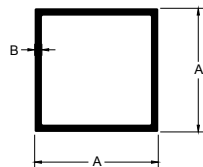

CÓDIGO		DIMENSÕES				PESO (Kg/m)
CDA	EQUIVALÊNCIA	MILÍMETROS		POLEGADAS		
		A	B	A	B	
TUB-4001	TQ-002	12,70	1,58	1/2	1/16	0,190
TUB-4002	TQ-003	15,87	1,59	5/8	-	0,246
TUB-4003	TQ-006	19,50	1,60	-	-	0,302
TUB-4061	TQ-023	25,40	1,00	1	-	0,264
TUB-4045	-	25,40	1,35	1	-	0,352
TUB-4008	TQ-058	25,40	1,50	1	-	0,388
TUB-4011	TQ-059	31,75	1,50	1,1/4	-	0,491
TUB-6003	-	38,10	1,10	1,1/2	-	0,440
TUB-4014	TQ-014	38,10	1,50	1,1/2	1/16	0,595
TUB-4020	-	50,80	1,88	2	-	0,996
TUB-4022	TQ-067	50,80	3,00	2	-	1,554
TUB-4024	TQ-066	76,20	3,00	3	-	2,379
TUB-4034	TQ-065	80,00	1,80	-	-	1,525
ALG-2087	-	87,00	1,80	-	-	1,662
TUB-4054	TQ-034	101,60	2,50	4	-	2,685

**PERFIL U ABAS IGUAIS**

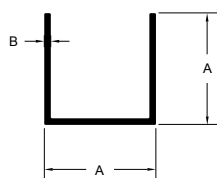

CÓDIGO		DIMENSÕES				PESO (Kg/m)
CDA	EQUIVALÊNCIA	MILÍMETROS		POLEGADAS		
		A	B	A	B	
U-036	PU-001	9,53	1,59	3/8	1/16	0,109
U-044	PU-002	12,70	1,58	1/2	1/16	0,149
U-509	PU-004	15,87	1,59	5/8	1/16	0,192
U-1167	PU-008	19,05	1,59	3/4	-	0,233
U-5005	PU-044	25,40	1,50	1	-	0,298
U-083	PU-020	38,10	3,20	1,1/2	-	0,935

# PERFIS TABELADOS

## PERFIL U ABAS DESIGUAIS

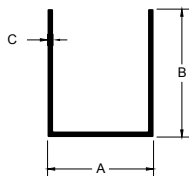

CÓDIGO		DIMENSÕES						PESO (Kg/m)
CDA	EQUIVALÊNCIA	MILÍMETROS			POLEGADAS			
		A	B	C	A	B	C	
U-555	PU-329	15,00	25,00	1,59	-	-	-	0,159
U-048	PU-204	15,88	9,52	2,38	-	-	3/32	0,195
U-054	PU-206	19,05	9,53	2,38	-	3/8	3/32	0,214
PU-207	-	19,05	12,70	1,98	3/4	1/2	-	0,216
U-5002	PU-216	35,00	17,00	1,50	-	-	-	0,267
BK-575	-	40,50	37,00	2,00	-	-	-	0,599
PI-001	-	100,00	26,50	1,50	-	-	-	0,604

## PERFIL T

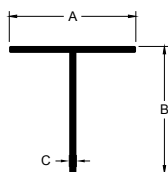

CÓDIGO		DIMENSÕES						PESO (Kg/m)
CDA	EQUIVALÊNCIA	MILÍMETROS			POLEGADAS			
		A	B	C	A	B	C	
T-076	PT-009	25,40	25,40	1,58	1	1	1/16	0,211

## VERGALHÃO REDONDO

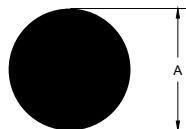

CÓDIGO		DIMENSÕES		PESO (Kg/m)
CDA	EQUIVALÊNCIA	MILÍMETROS	POLEGADAS	
		A	A	
VER-002	-	6,35	1/4	0,086
VER-010	VR-061	12,00	-	0,306
VER-011	VR-010	12,70	1/2	0,343
VER-102	VR-205	16,58	-	0,585
VER-103	-	18,63	-	0,740
VER-104	VR-145	22,75	-	1,100
VER-105	VR-099	24,05	-	1,230
VER-021	VR-020	25,40	1	1,373
VER-106	VR-146	26,99	1,1/16	1,550
VER-027	VR-023	31,75	1,1/4	2,145

VERGALHÃO QUADRADO



CÓDIGO		DIMENSÕES		PESO (Kg/m)
CDA	EQUIVALÊNCIA	MILÍMETROS	POLEGADAS	
		A	A	
VER-4002	VQ-001	6,35	1/4	0,109

Y-206 (CM-004)

0.280 Kg/m

Contramarco

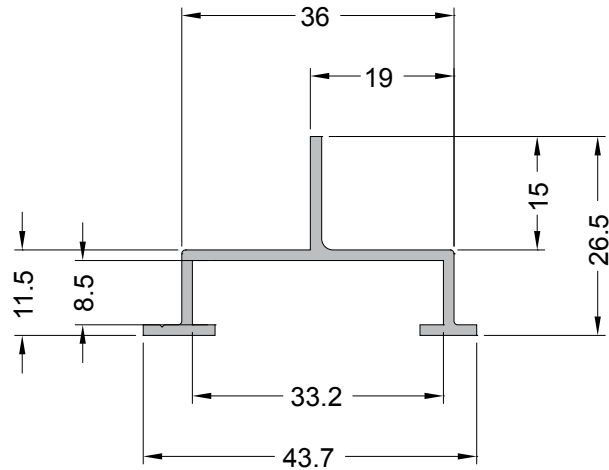

E-494 (CM-126)

0.450 Kg/m

Contramarco

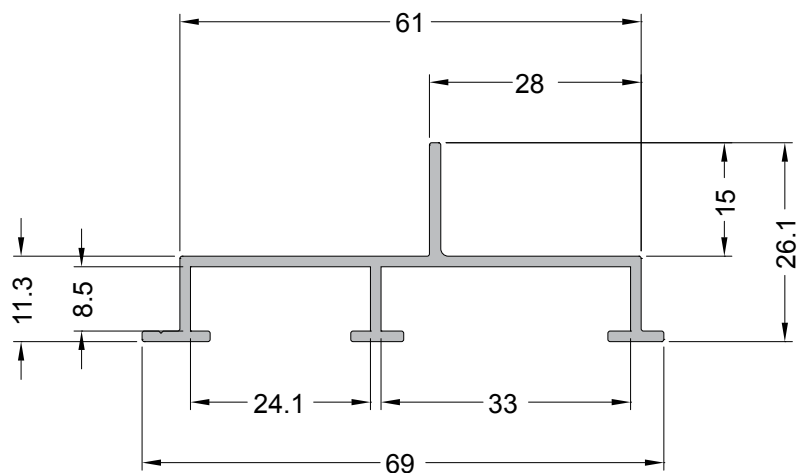

E-495 (CM-125)

0.452 Kg/m

Contramarco

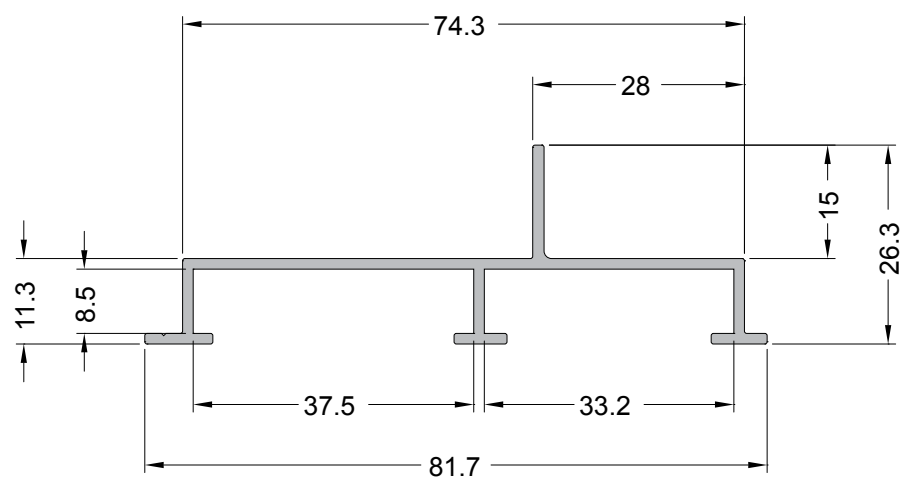

ALG-3012  
0.387 Kg/m  
Contramarco

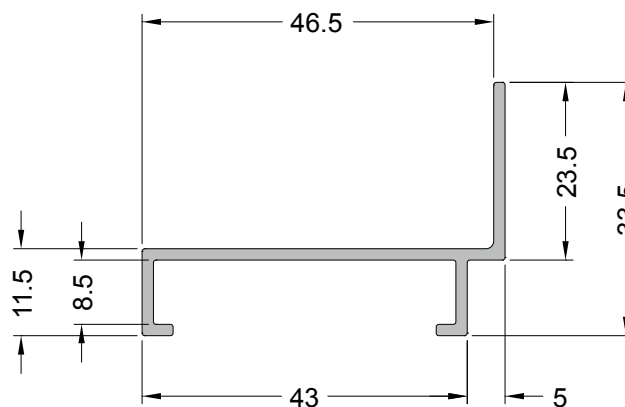

Y-715 (CM-129)  
0.456 Kg/m  
Contramarco

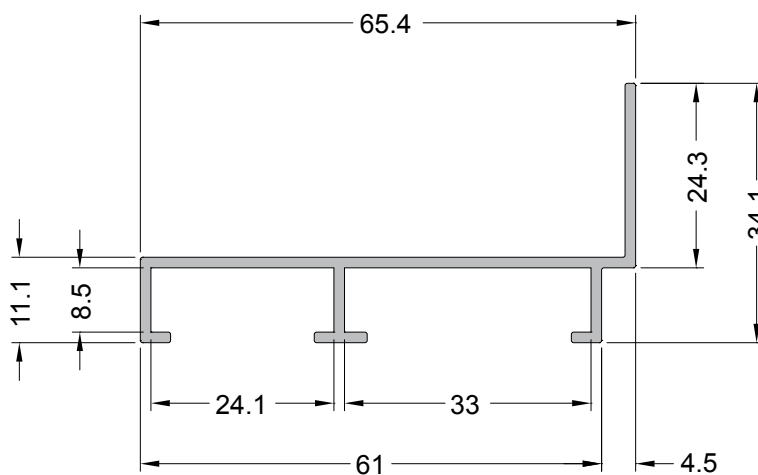

E-517  
0.502 Kg/m  
Contramarco

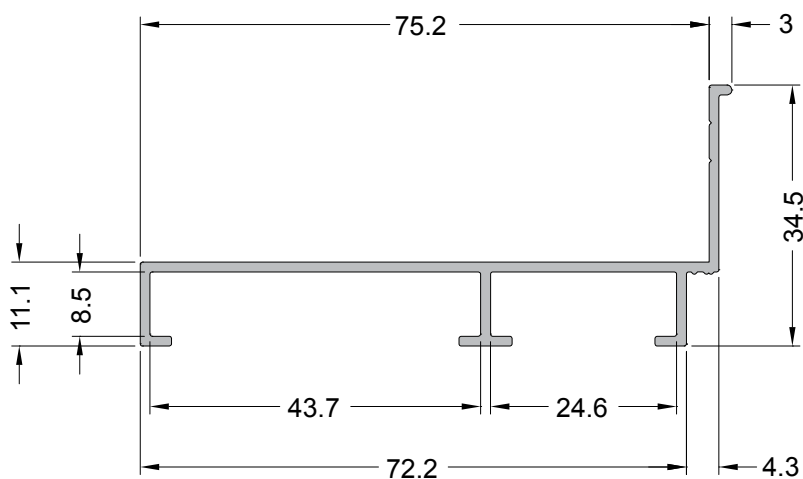

CX-3273  
0.352 Kg/m  
Contramarco

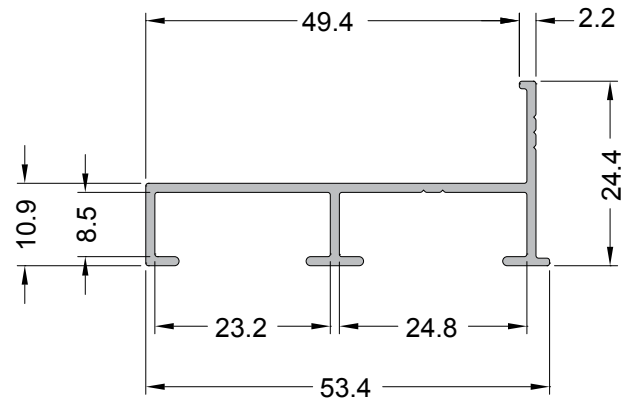

CX-3289  
0.544 Kg/m  
Contramarco

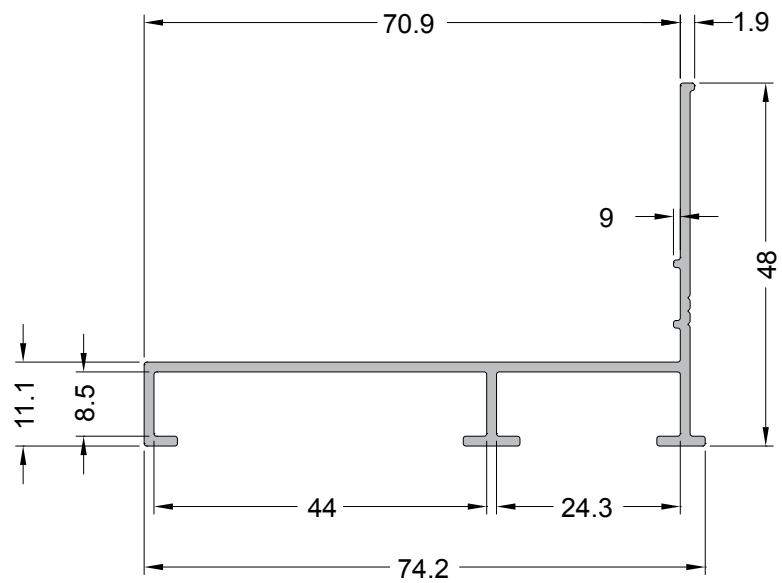

Y-687 (CM-113)  
0.441 Kg/m  
Contramarco

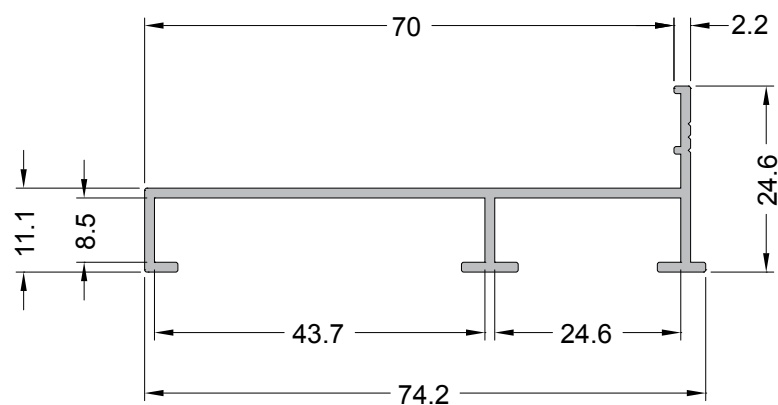

CM-168  
0.957 Kg/m  
Contramarco

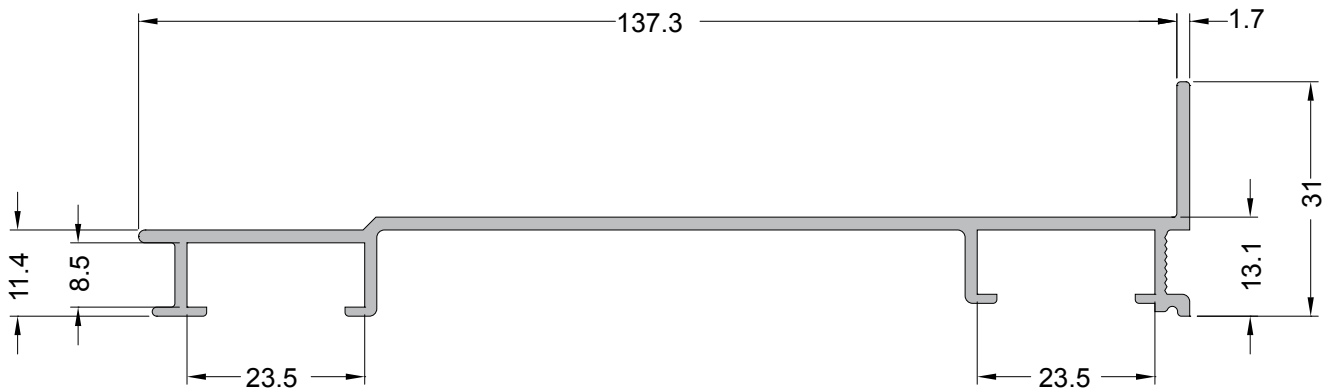

CM-173  
0.509 Kg/m  
Contramarco

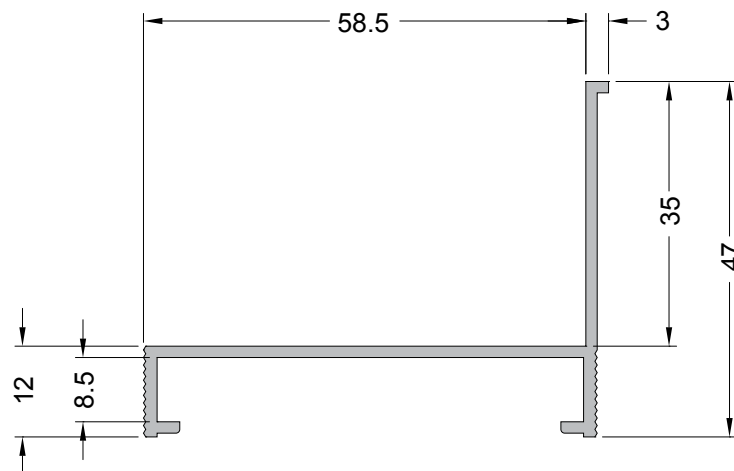

Y-1174 (CM-174)  
0.369 Kg/m  
Contramarco

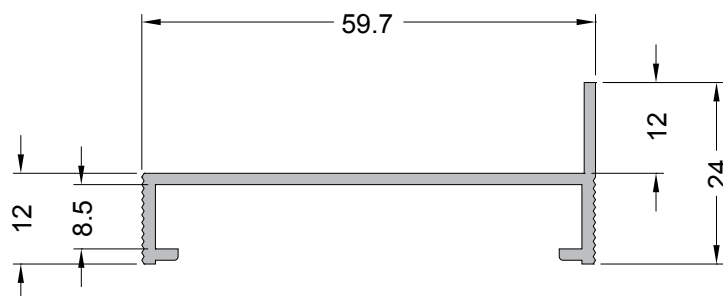



CM-098  
0.384 Kg/m  
Contramarco - Porta

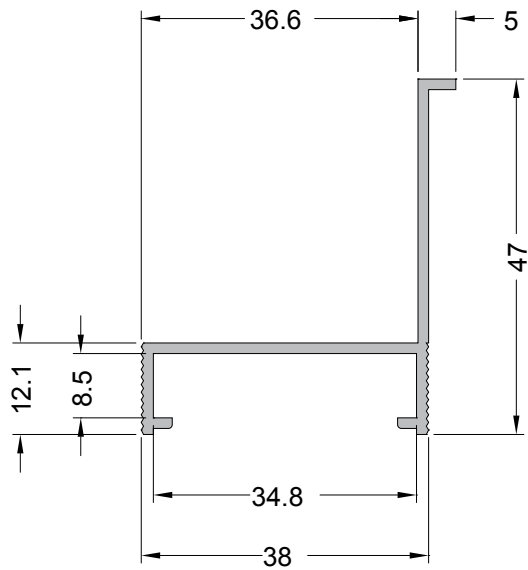

Y-1151 (CM-151)  
0.257 Kg/m  
Contramarco - Porta

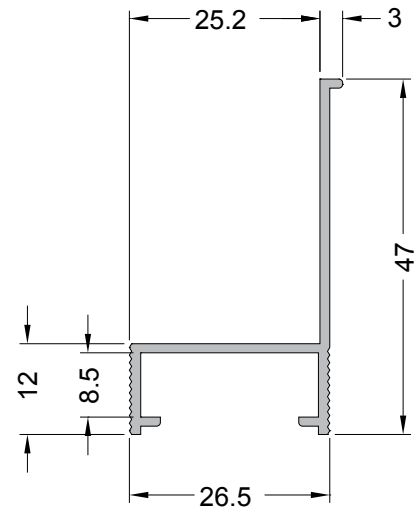

CM-1002 (CM-060)  
0.271 Kg/m  
Contramarco

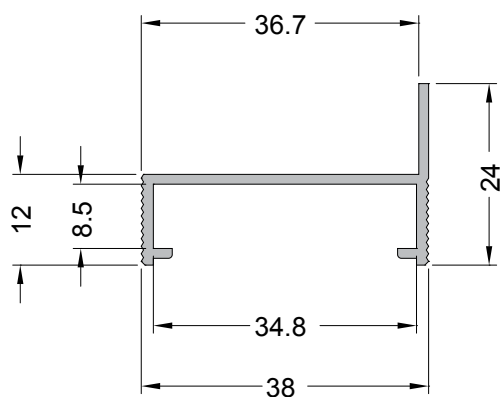

Y-1063 (CM-063)  
0.229 Kg/m  
Contramarco

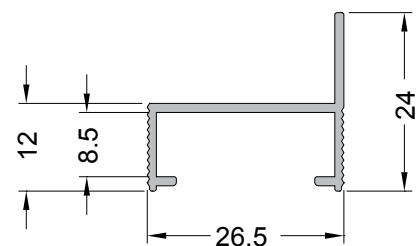

Y-1000 (CM-200)

0.185 Kg/m

Contramarco

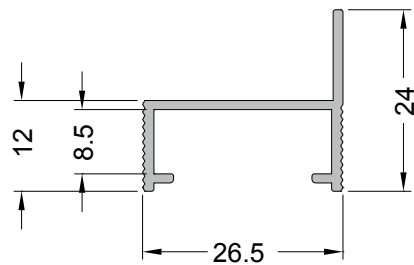

CX-3274

0.166 Kg/m

Contramarco

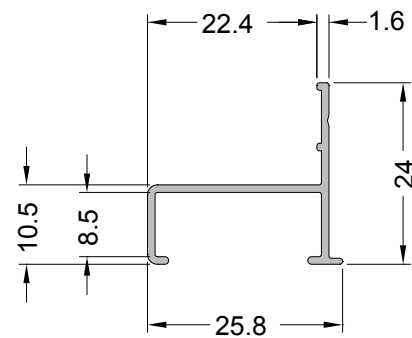

Y-721 (CM-110)

0.202 Kg/m

Contramarco

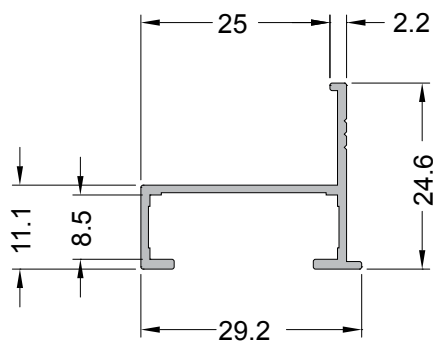

Y-120 (25-557)

0.233 Kg/m

Contramarco

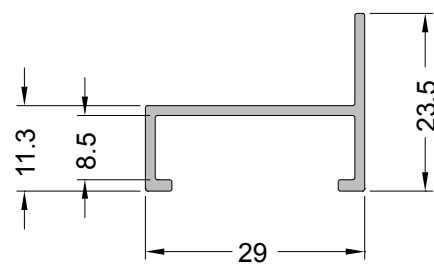

CM-103

0.291 Kg/m

Contramarco

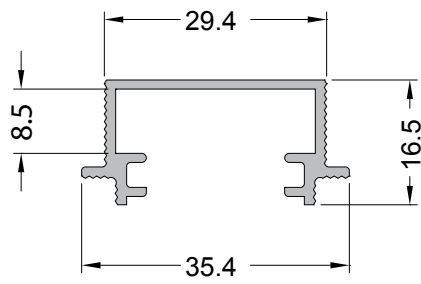

L-468 (CL-009)

1.647 Kg/m

Conexão

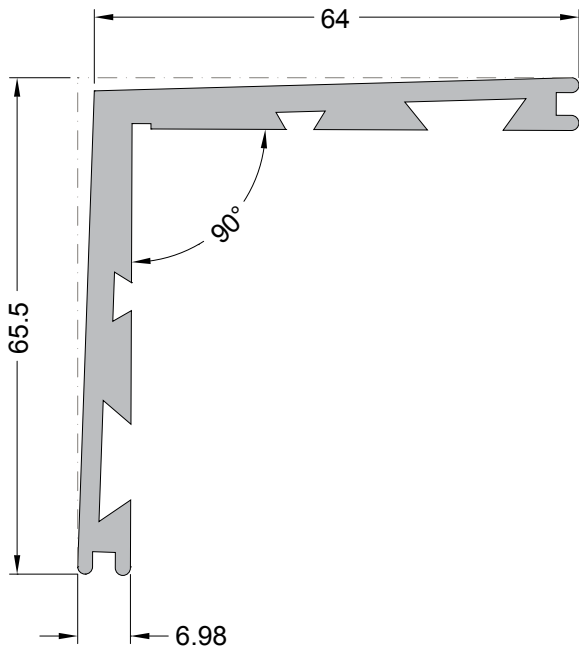

L-579 (CL-044)

1.014 Kg/m

Conexão

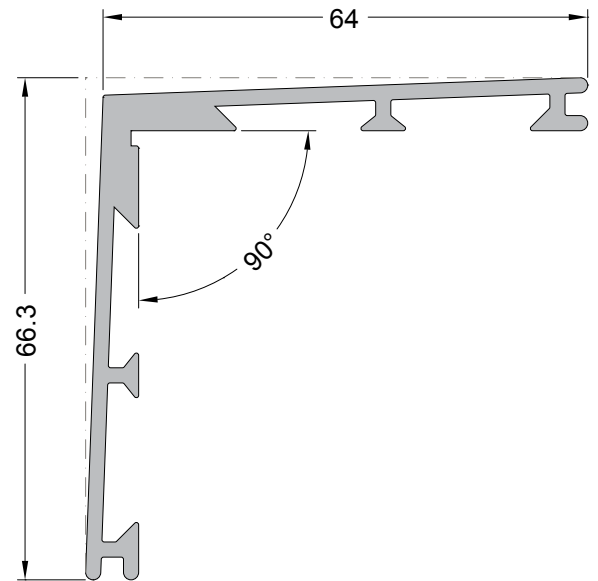

BAR-4037 (CL-010)

0.382 Kg/m

Cunha

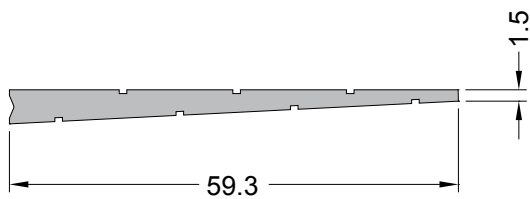

L-1468 (CL-006)

1.049 Kg/m

Conexão

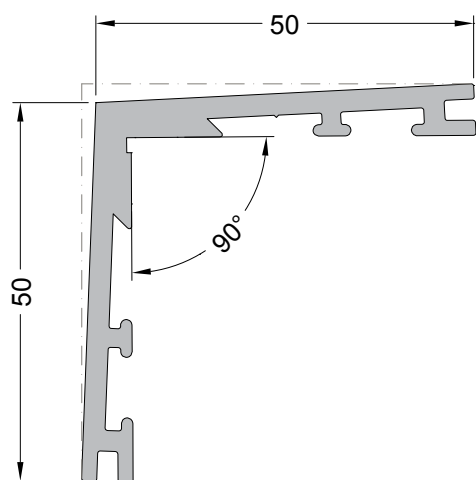

BAR-4157 (CL-011)

0.318 Kg/m

Cunha

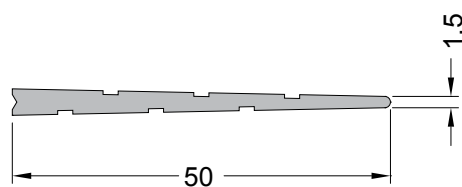

MP-347  
0.197 Kg/m  
Arremate

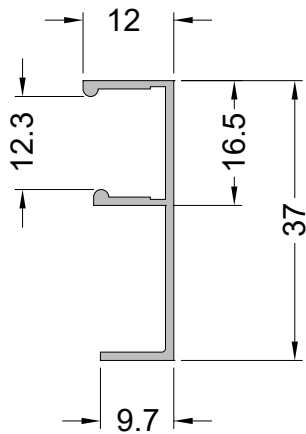

ME-092  
0.160 Kg/m  
Arremate

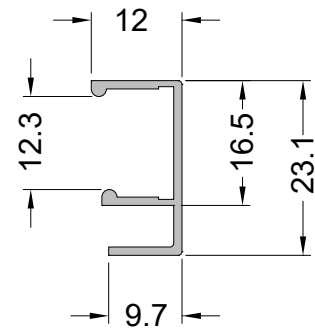

CO-71602  
0.202 Kg/m  
Arremate

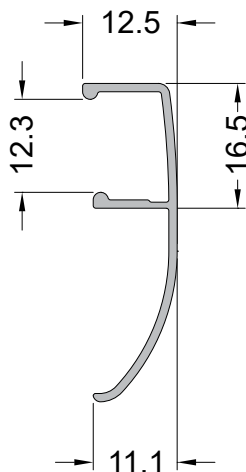

CO-71601  
0.167 Kg/m  
Arremate

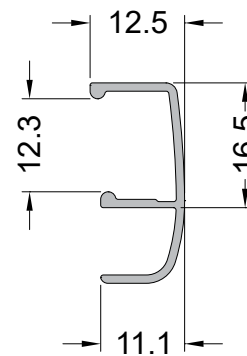

CX-3219  
0.207 Kg/m  
Arremate

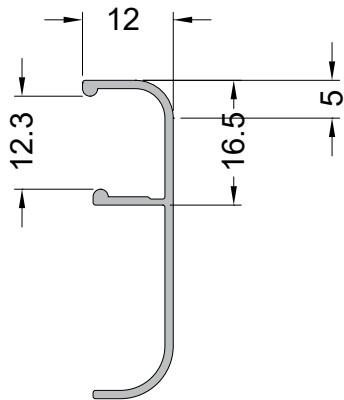

T-095  
0.384 Kg/m  
Arremate

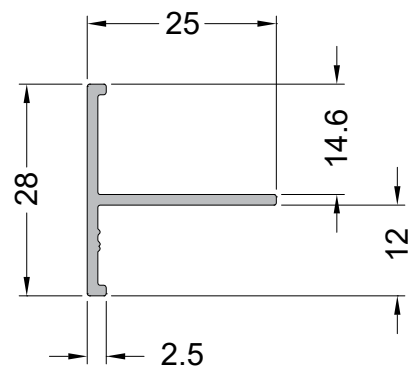

T-102  
0.192 Kg/m  
Arremate

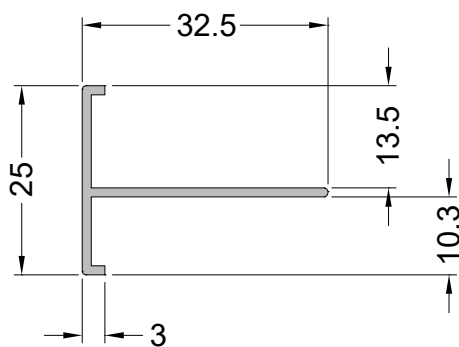

ALG-3011  
0.379 Kg/m  
Arremate

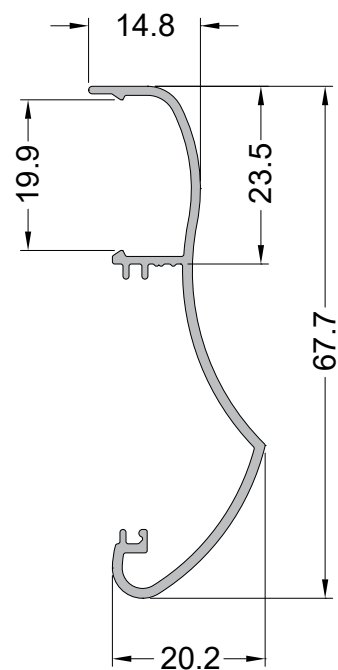



E-504 (CM-111)

0.172 Kg/m

Arremate

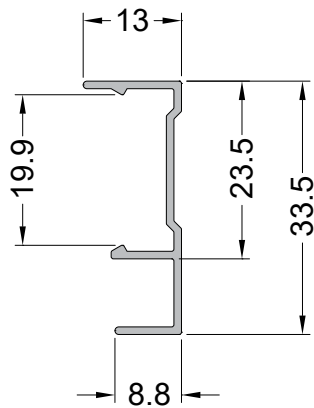

E-613 (CM-130)

0.161 Kg/m

Arremate

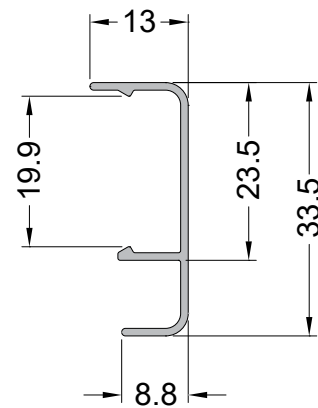

T-124 (CM-006)

0.166 Kg/m

Arremate

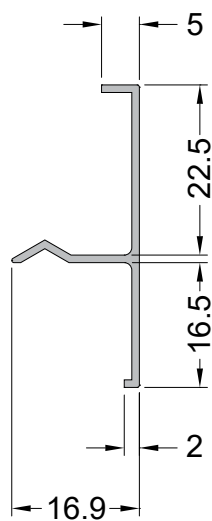

T-122 (CM-007)

0.157 Kg/m

Arremate

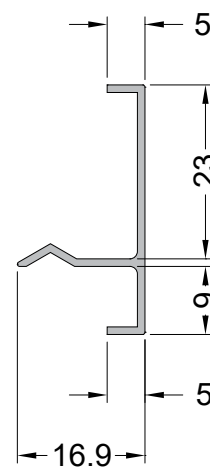

L-516 (CM-029)

0.308 Kg/m

Arremate Soleira

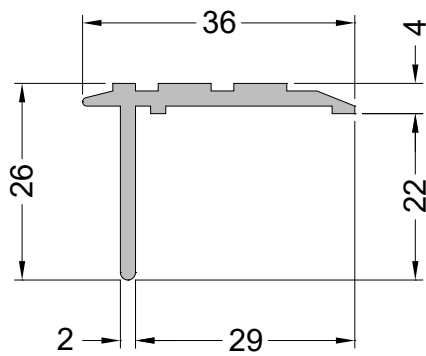

ME-013

0.236 Kg/m

Arremate Soleira

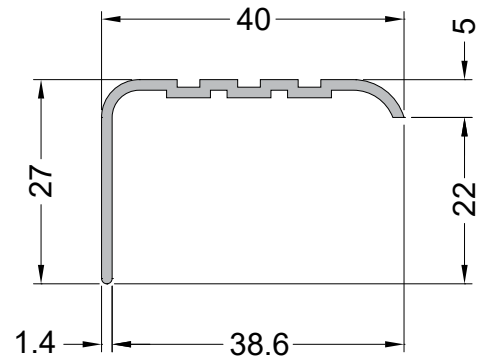

CM-169

0.383 Kg/m

Arremate Soleira

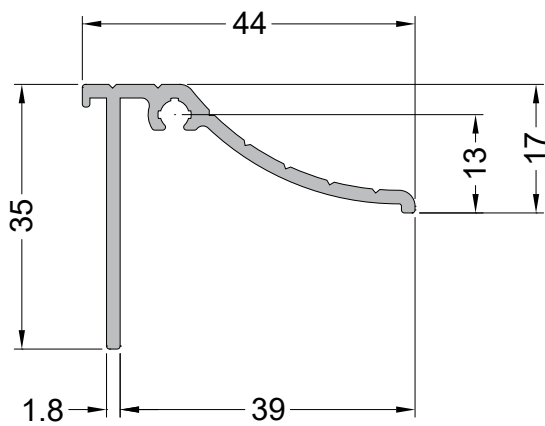

L-213

0.697 Kg/m

Arremate Soleira

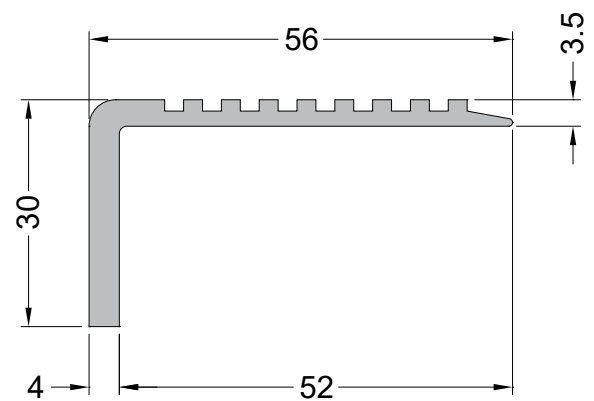

L-460  
0.141 Kg/m  
Arremate Soleira

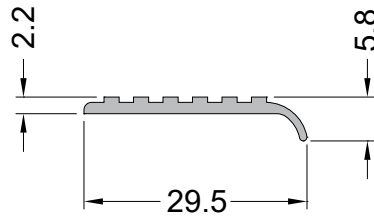

CX-640  
0.990 Kg/m  
Arremate

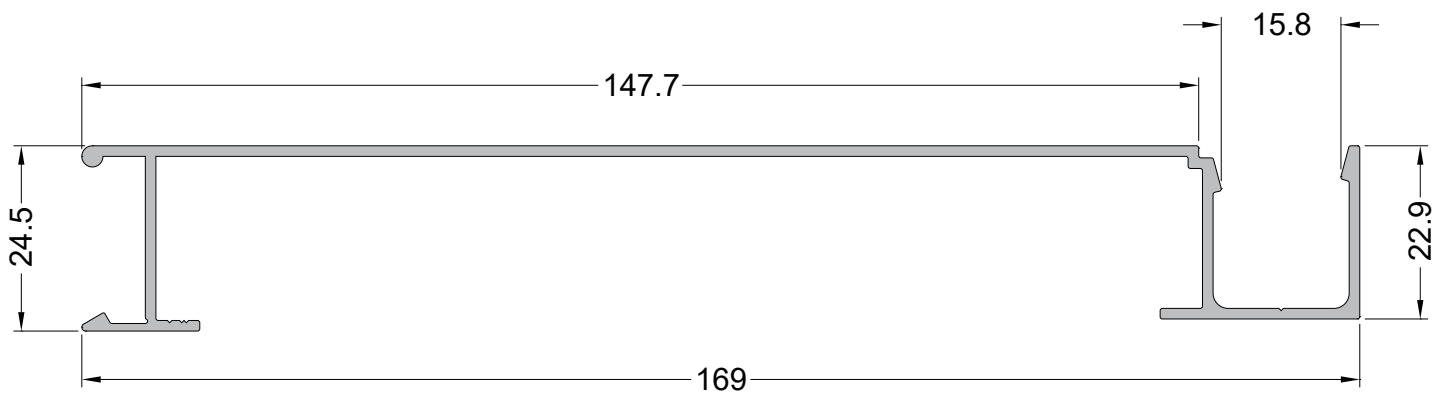

CX-641  
0.667 Kg/m  
Arremate

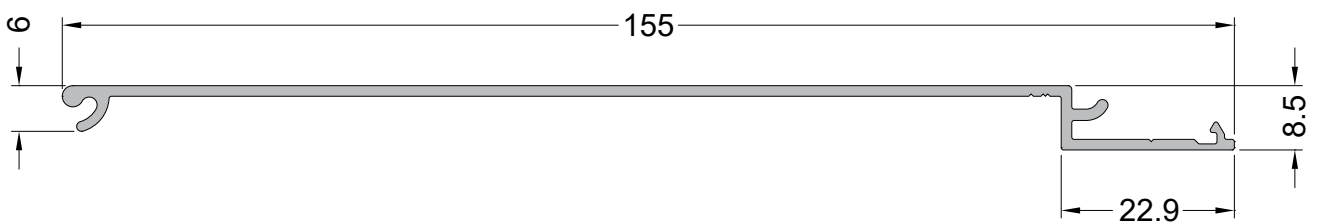

Y-418

0.279 Kg/m

Marco

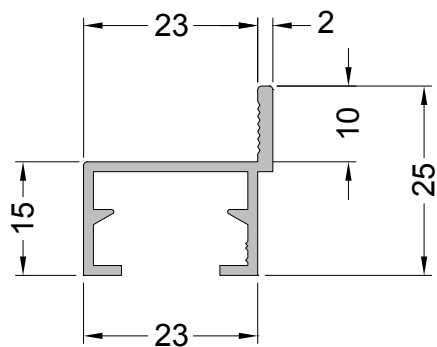

Y-420

0.384 Kg/m

Fixo

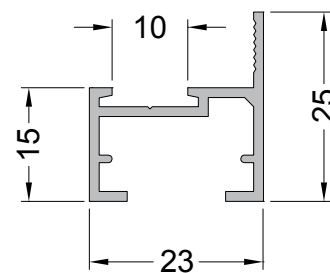

P-335 (23-005)

0.316 Kg/m

Folha

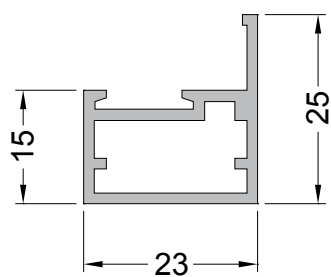

P-337 (23-001)

0.375 Kg/m

Folha

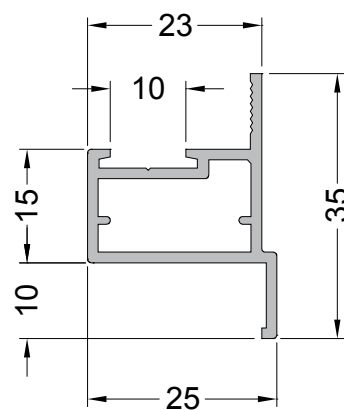

P-336  
0.357 Kg/m  
Folha

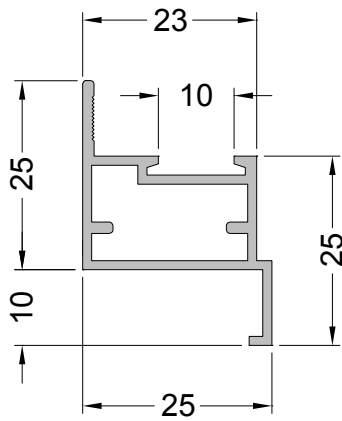

Y-473  
0.360 Kg/m  
Marco

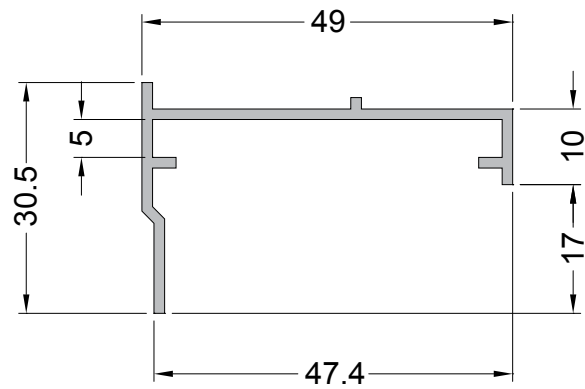

E-290 (E-482)

0.853 Kg/m

Marco Superior

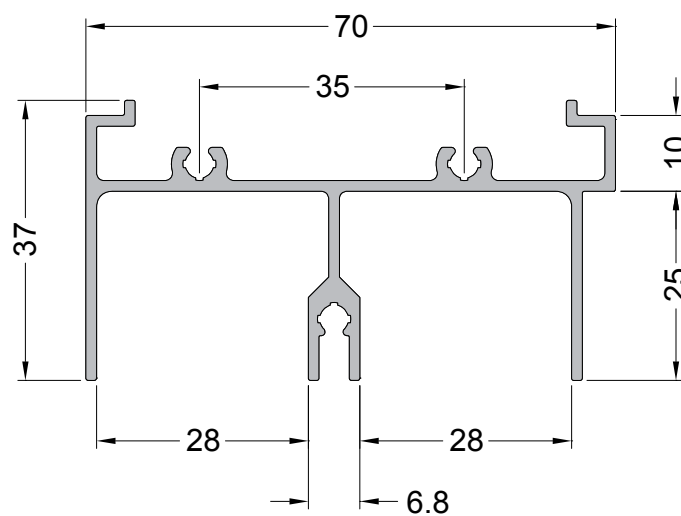

Z-176 (25-516)

0.812 Kg/m

Marco Inferior

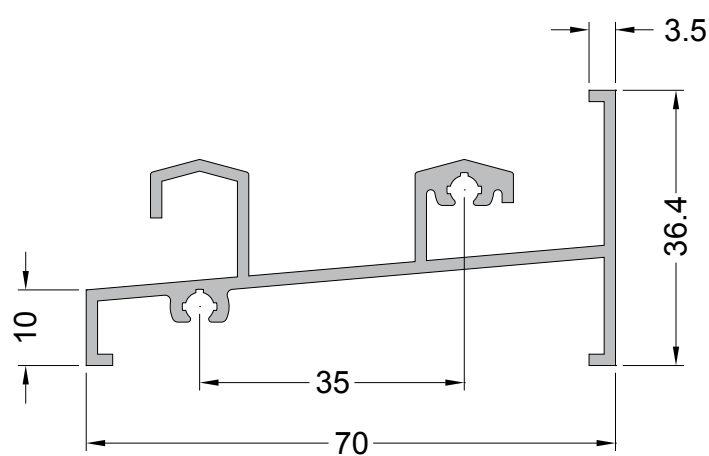

Z-174 (25-515)

0.661 Kg/m

Marco Inferior

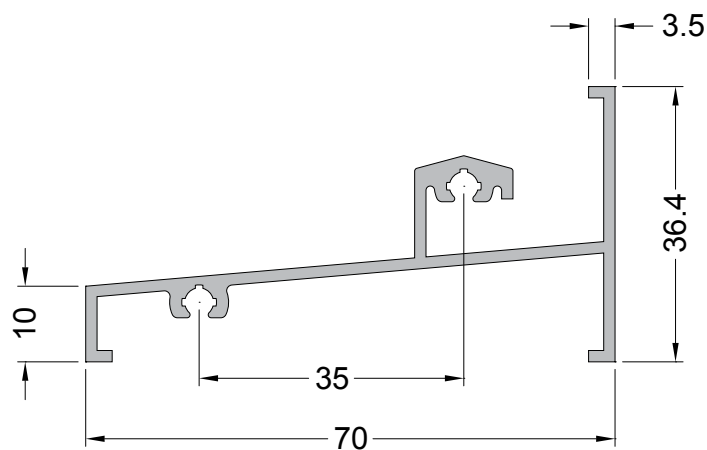

Z-175 (25-517)

0.539 Kg/m

Marco Travessa Liso

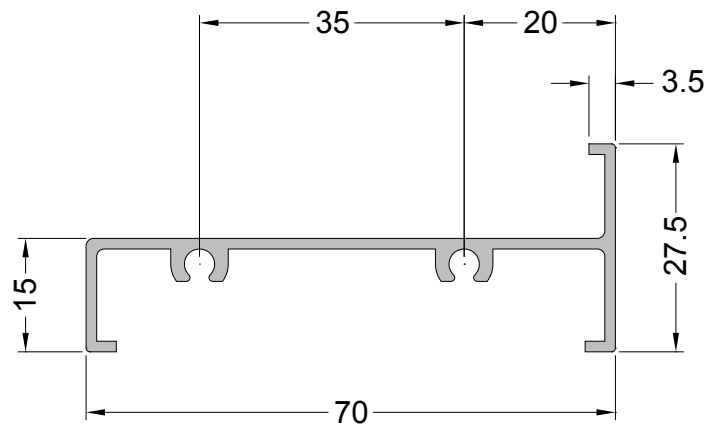

E-277 (25-514)

0.491 Kg/m

Marco Lateral

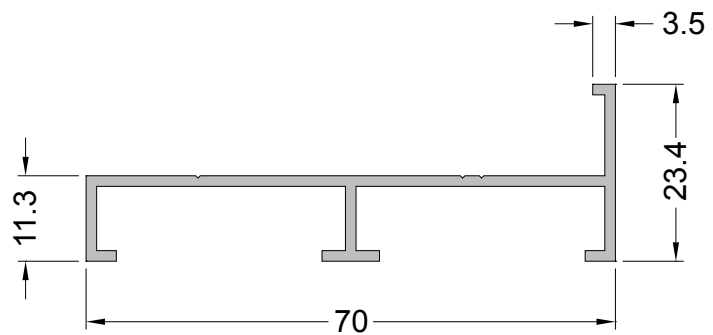

P-274 (FC-070)

0.954 Kg/m

Coluna

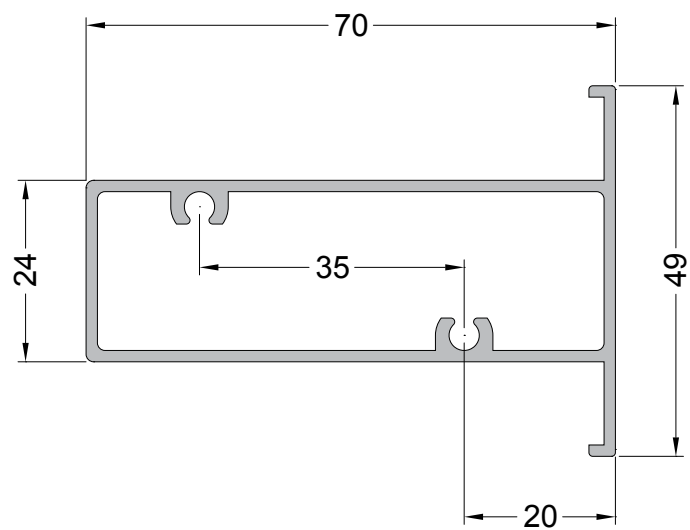



P-570 (PE-099)

1.248 Kg/m

Coluna

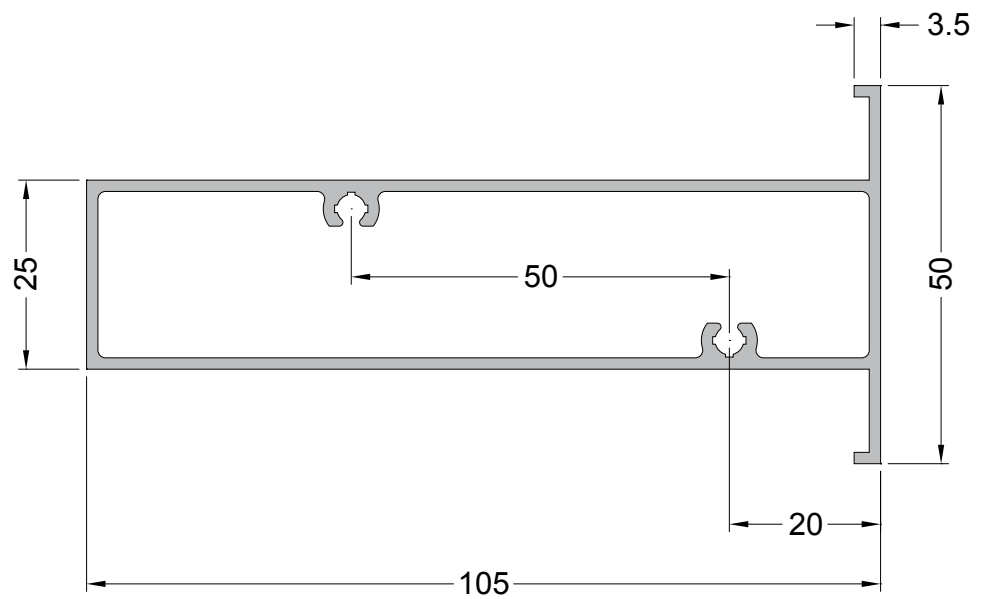

Z-114 (25-560)

0.531 Kg/m

Marco

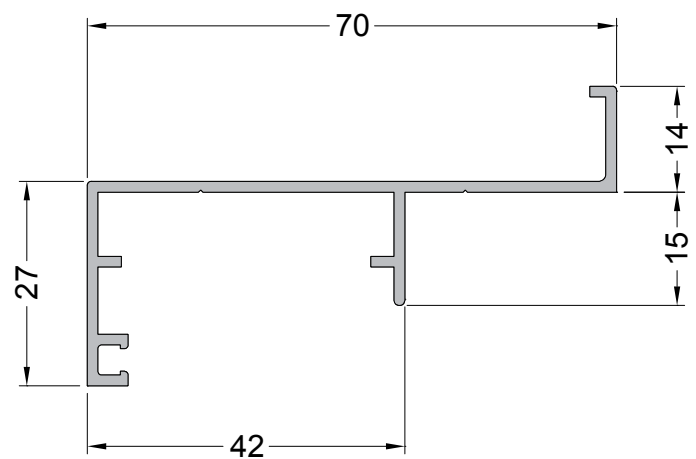

Z-192

0.780 Kg/m

Marco

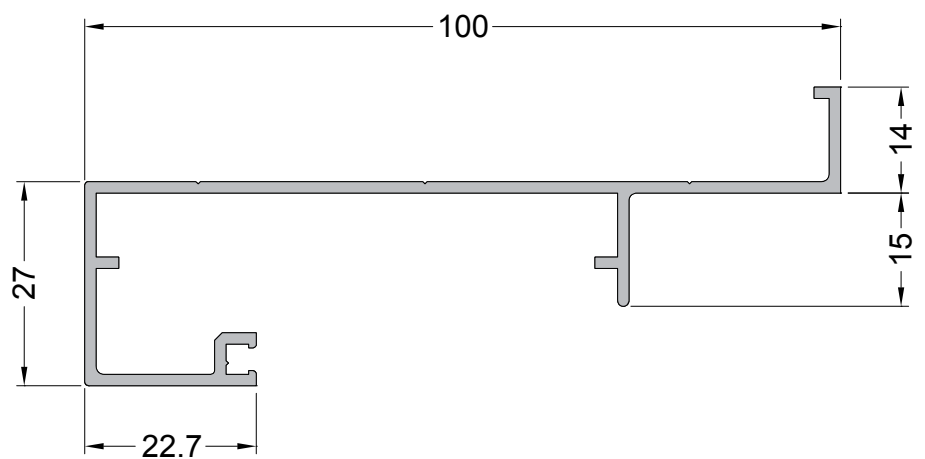

Y-195 (25-565)

0.474 Kg/m

Folha

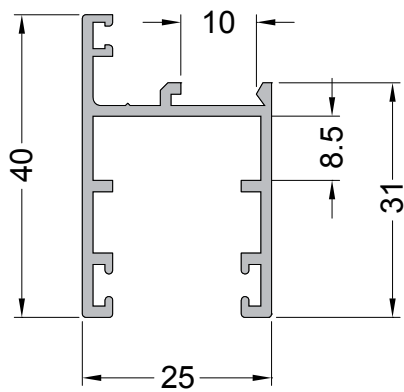

A-048 (25-502)

0.671 Kg/m

Folha

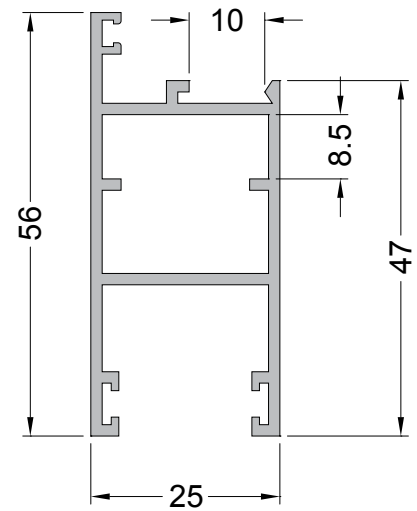

P-319 (25-508)

0.686 Kg/m

Folha

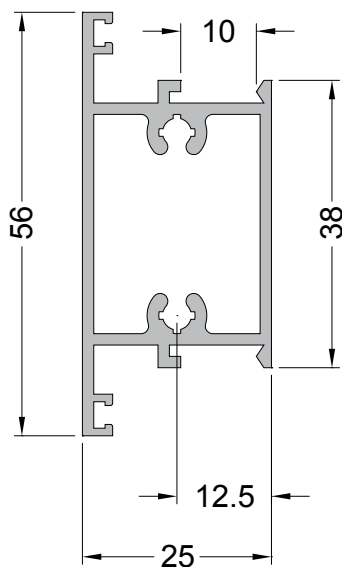

Y-196 (25-500)

0.462 Kg/m

Folha

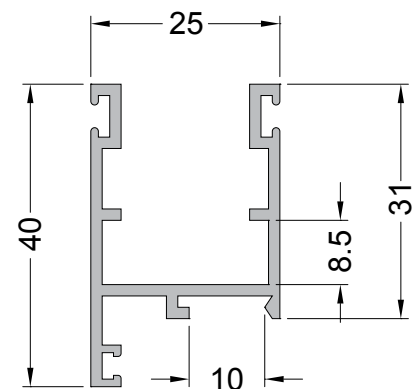

P-152 (25-569)

0.641 Kg/m

Folha

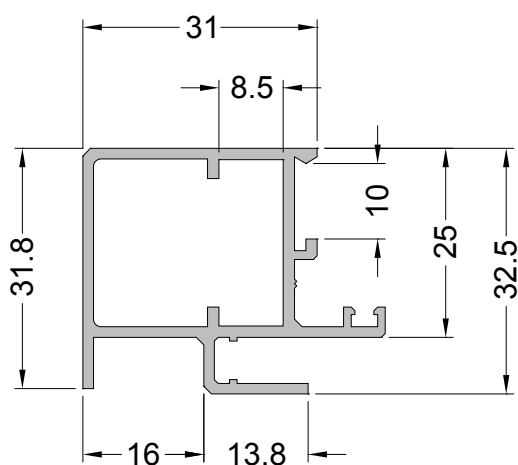

P-151 (25-568)

0.511 Kg/m

Folha

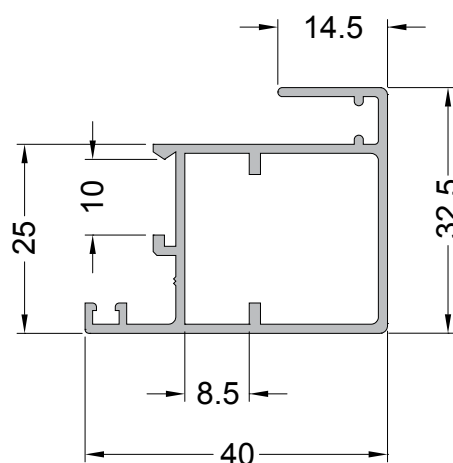

P-140 (25-570)

0.459 Kg/m

Folha

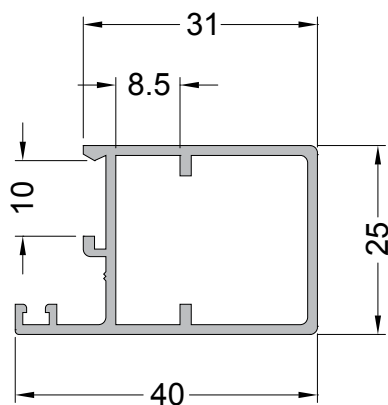

P-318 (25-504)

0.650 Kg/m

Folha

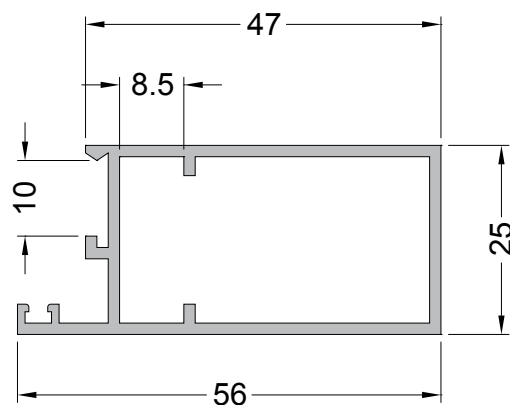

I-122 (25-019)

0.458 Kg/m

Folha

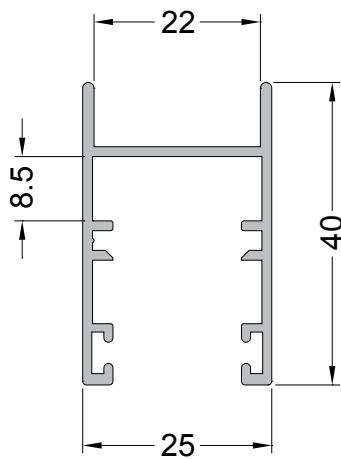

A-055 (25-012)

0.463 Kg/m

Folha

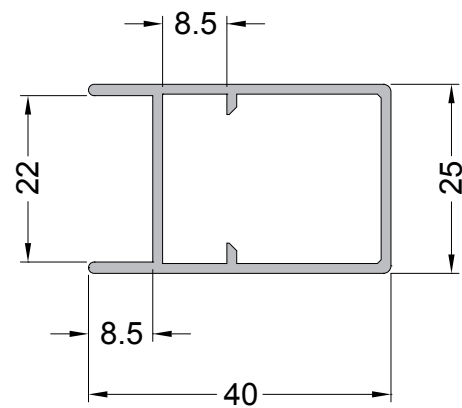

A-194 (25-679)

0.653 Kg/m

Folha

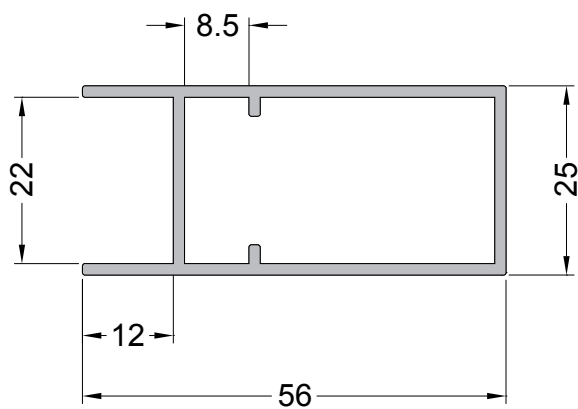

I-309 (25-697)

0.425 Kg/m

Folha

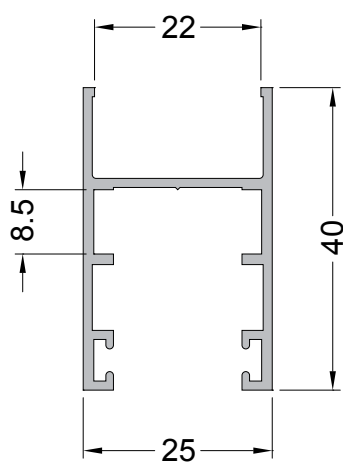

A-204 (25-334)

0.444 Kg/m

Folha

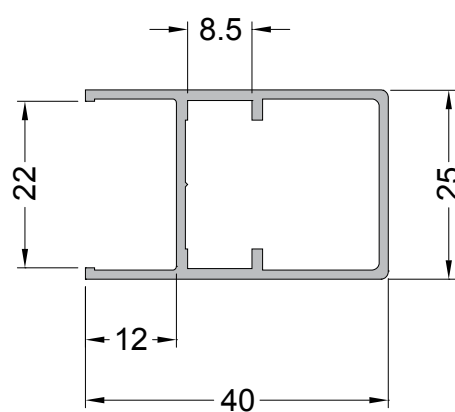

P-412 (25-540)

0.542 Kg/m

Marco

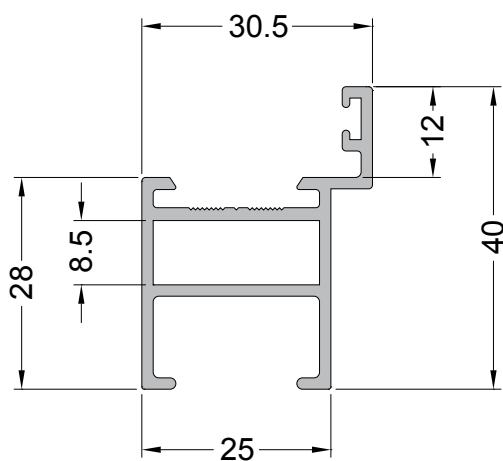

L-715 (25-548)

0.282 Kg/m

Mata Junta

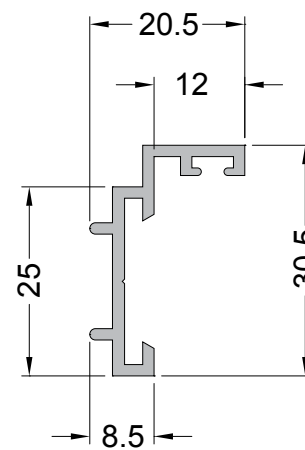

P-414 (25-542)

0.674 Kg/m

Folha

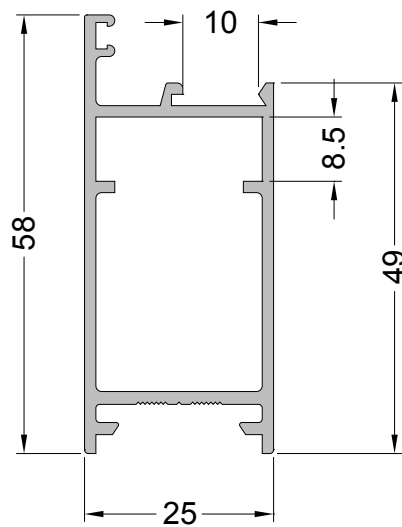

P-416 (25-546)

0.591 Kg/m

Folha

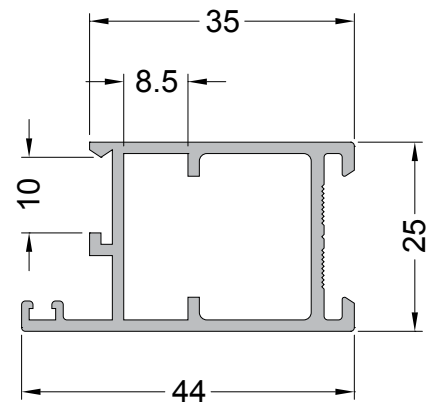

A-207 (25-333)

0.598 Kg/m

Folha

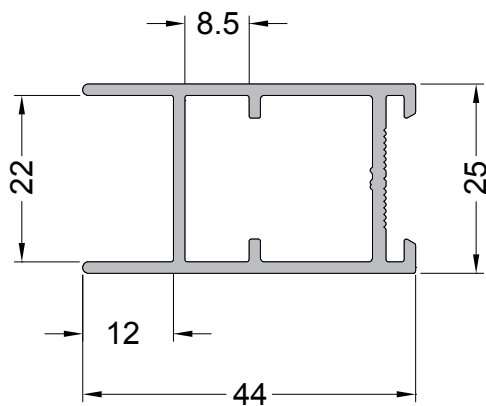

P-153 (25-026)

0.529 Kg/m

Travessa

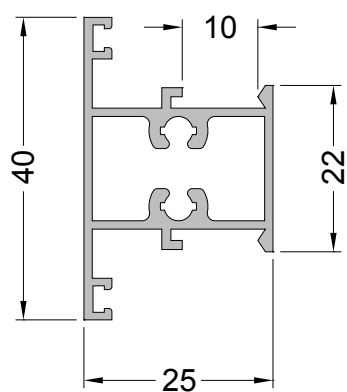

Y-215 (25-561)

0.534 Kg/m

Marco

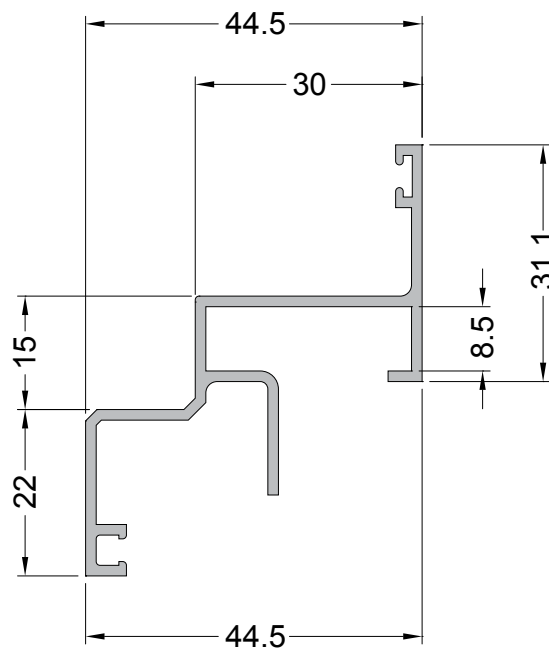

P-255 (25-023)

0.647 Kg/m

Travessa

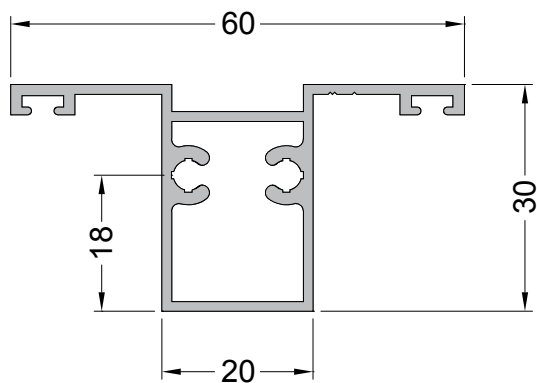

P-574 (25-669)

0.636 Kg/m

Travessa

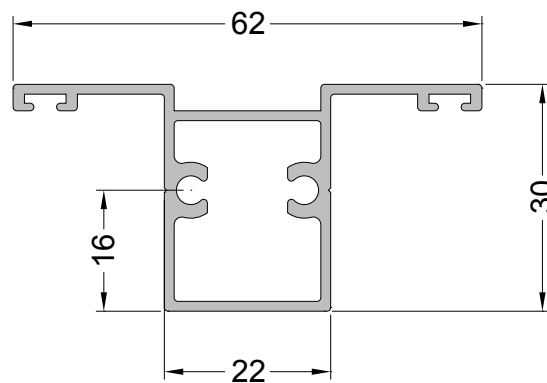

L-387 (CL-015)

0.220 Kg/m

Pingadeira

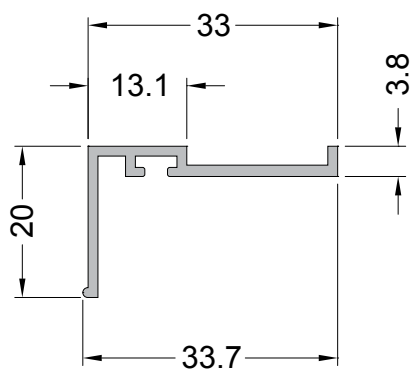

Y-200 (25-554)

0.257 Kg/m

Batedeira

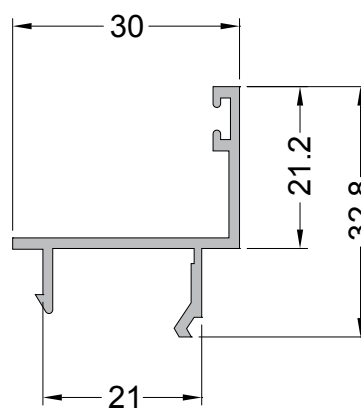

U-683 (CL-050)

0.149 Kg/m

Guia

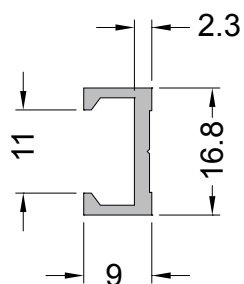

P-155 (25-522)

0.542 Kg/m

Folha

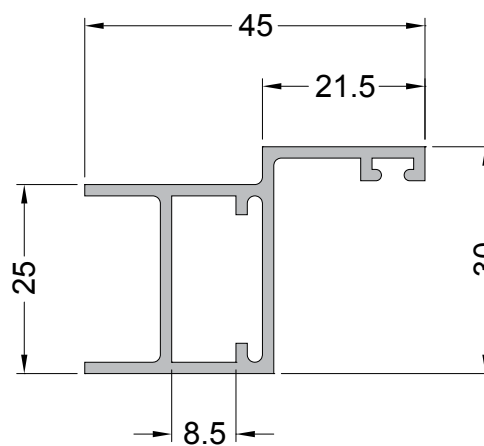



A-206

0.404 Kg/m

Folha

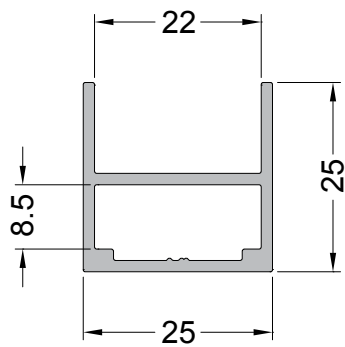

A-056

0.373 Kg/m

Folha

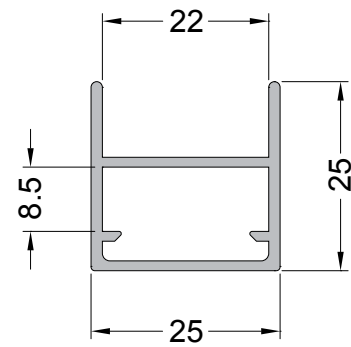

Y-126 (25-556)

0.333 Kg/m

Marco

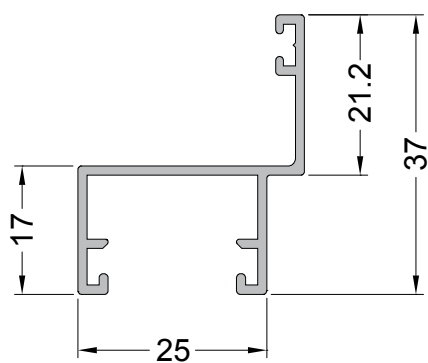

P-161 (25-004)

0.479 Kg/m

Folha

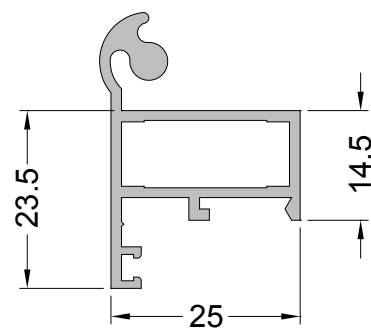

P-146 (25-559)

0.436 Kg/m

Folha

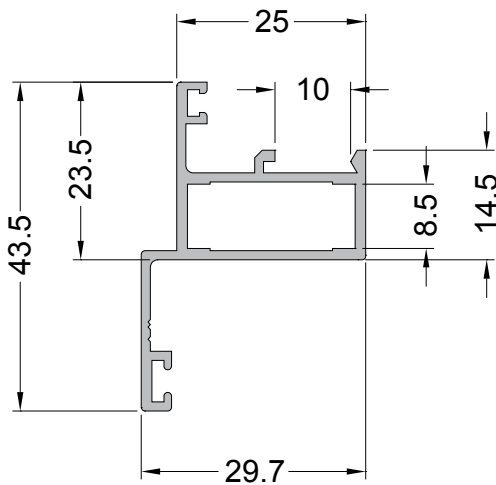

P-145 (25-572)

0.443 Kg/m

Folha

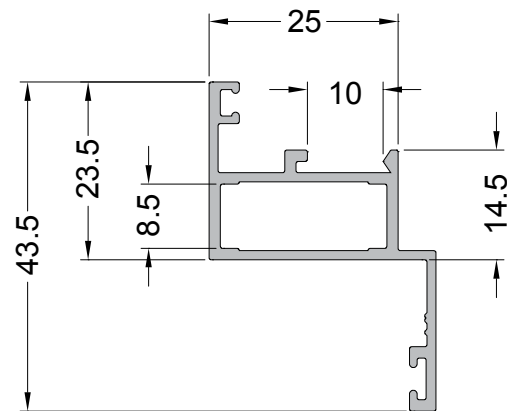

P-167 (25-523)

0.378 Kg/m

Folha

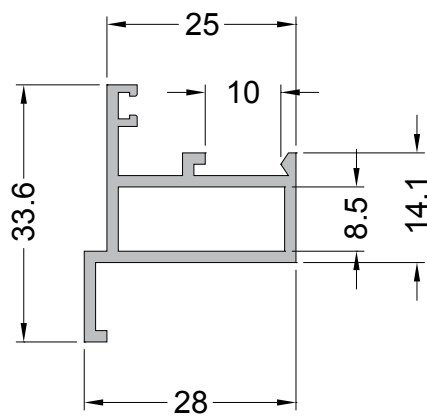

P-166 (25-524)

0.427 Kg/m

Folha

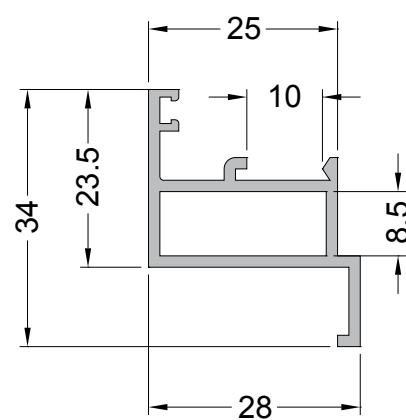

I-105 (DV-053)

0.229 Kg/m

Mata Junta

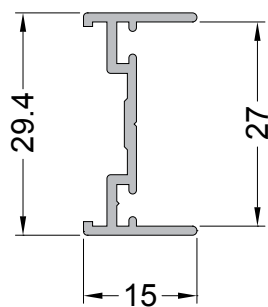

P-227 (25-549)

0.462 Kg/m

Folha

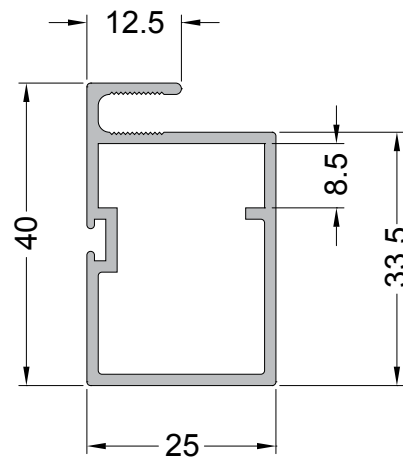

U-425 (25-510)

0.155 Kg/m

Trilho

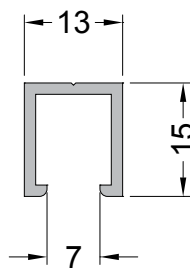

U-681 (25-032)

0.132 Kg/m

Guia

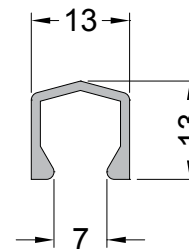

P-147 (25-555)

0.328 Kg/m

Folha

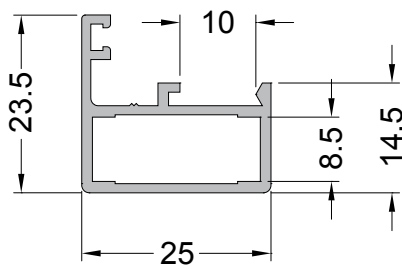

P-525

0.309 Kg/m

Folha

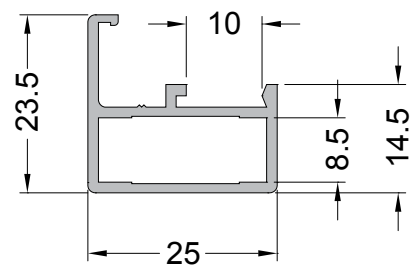

Y-197 (25-027)

0.280 Kg/m

Folha

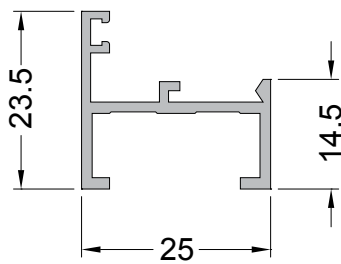

E-386 (20-197)

0.602 Kg/m

Marco

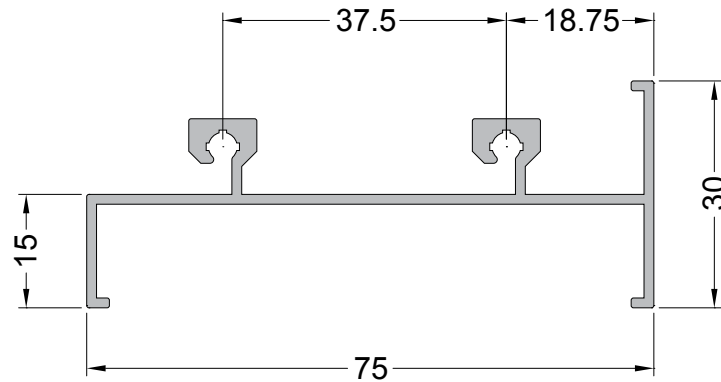

Y-487 (28-199)

0.593 Kg/m

Marco

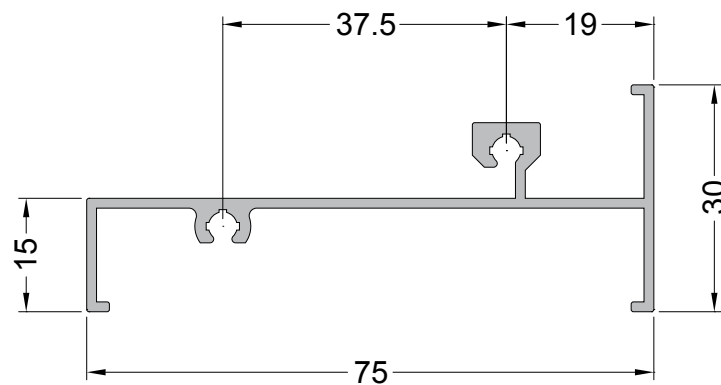

P-818 (28-057)

0.525 Kg/m

Marco Travessa Liso

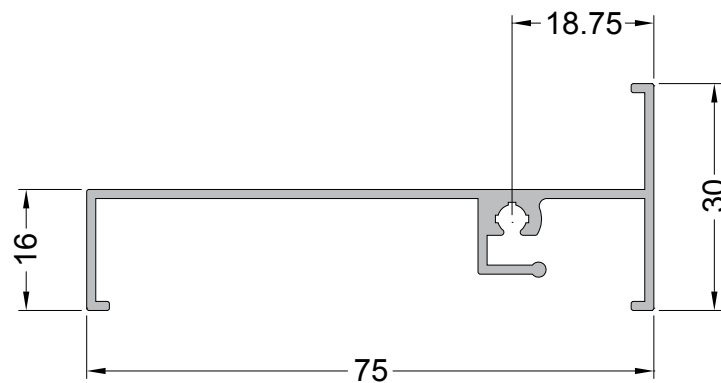

P-816 (28-049)

0.560 Kg/m

Marco Travessa Liso

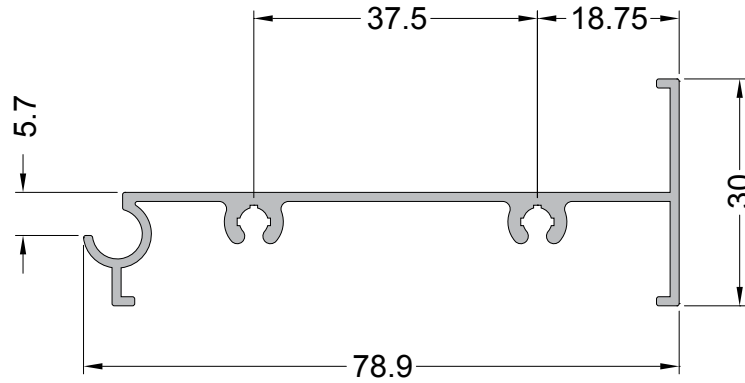

Y-632 (28-029)

0.398 Kg/m

Marco

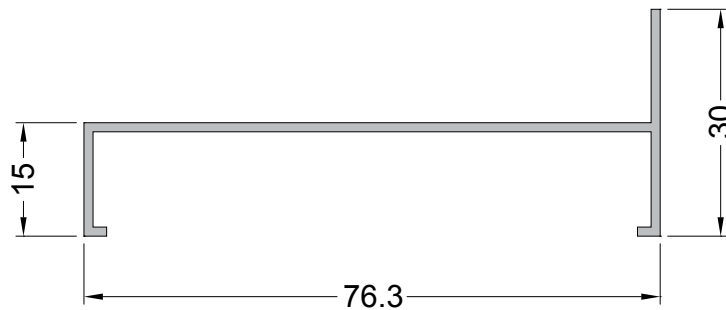

Y-301 (28-523)

0.431 Kg/m

Marco

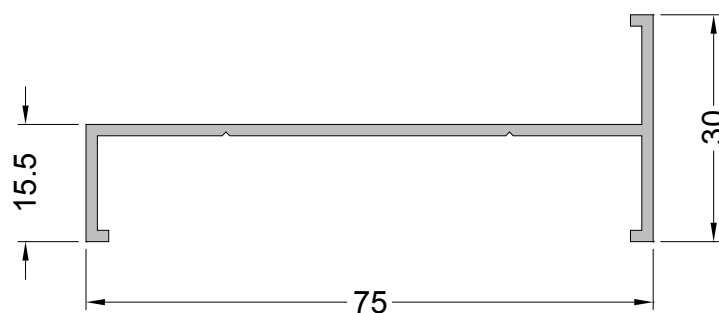

Y-325 (28-525)

0.586 Kg/m

Marco

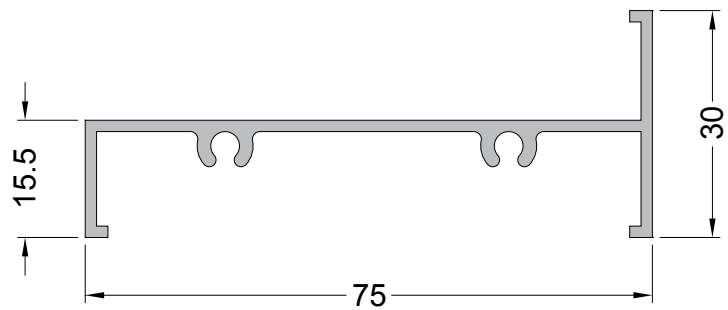

P-205 (28-205)

0.881 Kg/m

Coluna

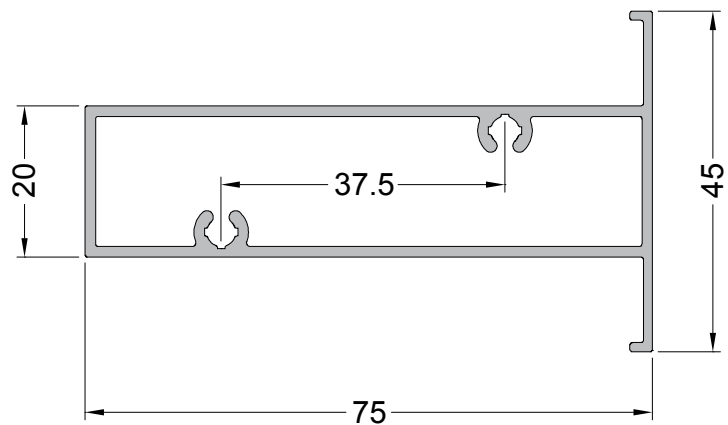

Y-626 (28-002)

0.266 Kg/m

Folha

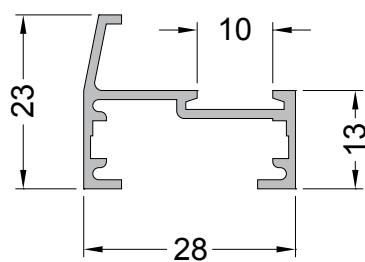

P-517 (28-001)

0.326 Kg/m

Folha

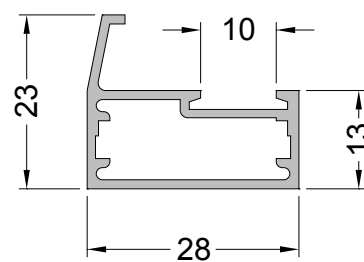

P-521 (28-048)

0.418 Kg/m

Folha

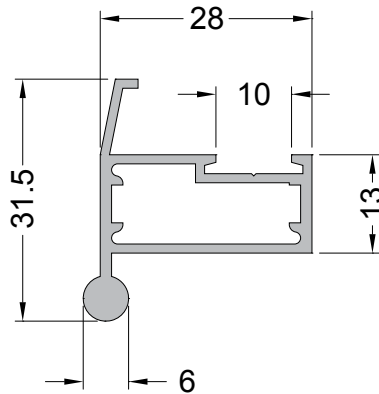

U-992 (28-051)

0.214 Kg/m

Marco

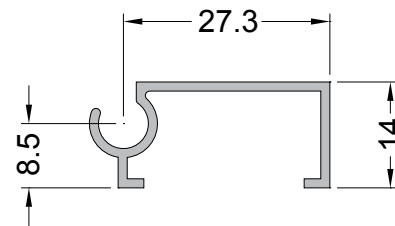

P-518 (28-004)

0.375 Kg/m

Folha

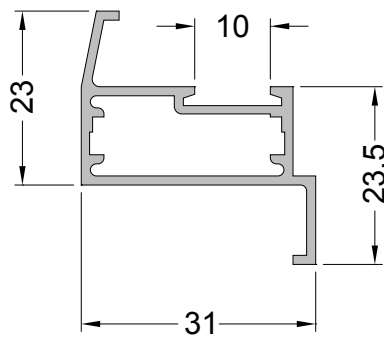

P-519 (28-003)

0.375 Kg/m

Folha

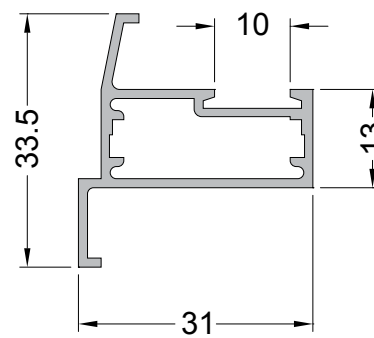

Y-625 (28-006)

0.385 Kg/m

Folha

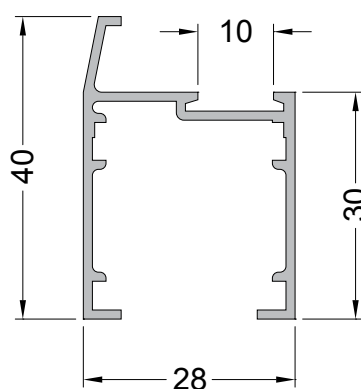

P-513 (28-005)

0.434 Kg/m

Folha

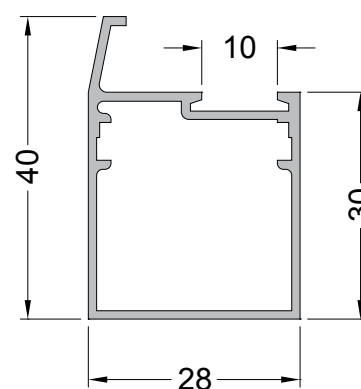



A-176 (28-010)

0.470 Kg/m

Folha

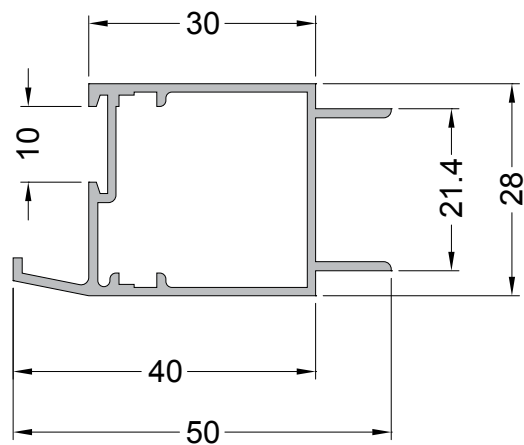

P-516 (28-009)

0.469 Kg/m

Folha

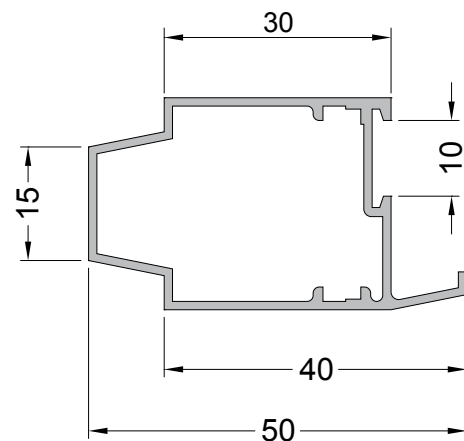

P-514 (28-008)

0.479 Kg/m

Folha

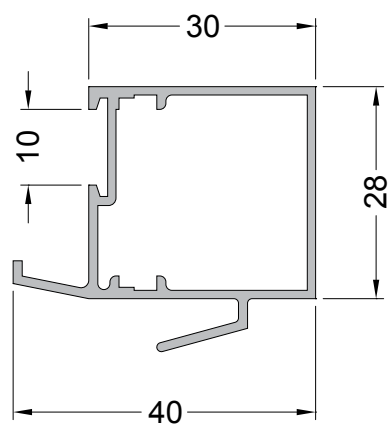

P-515 (28-007)

0.484 Kg/m

Folha

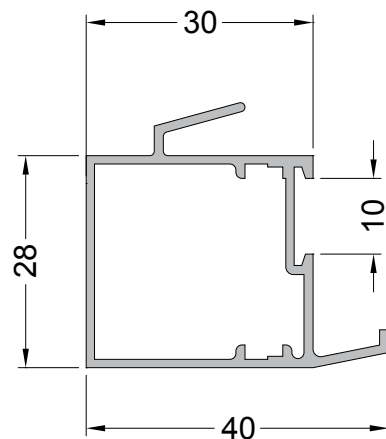

P-530 (28-012)

0.538 Kg/m

Folha

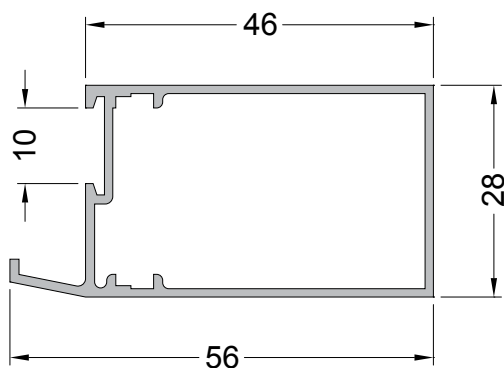

P-528 (28-928)

0.398 Kg/m

Travessa

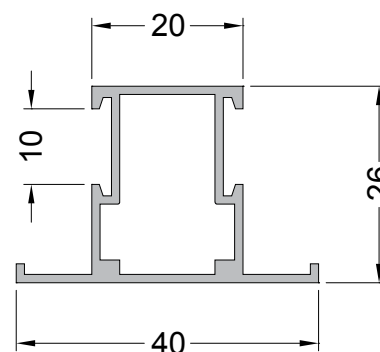

U-900 (28-514)

0.225 Kg/m

Marco

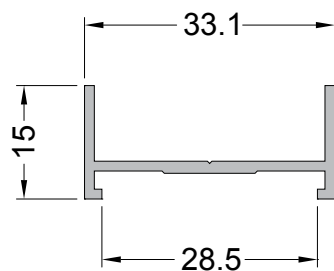

Y-628 (28-011)

0.234 Kg/m

Marco

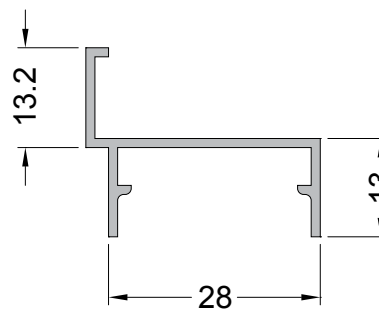

U-804 (BG-006)

0.100 Kg/m

Baguete

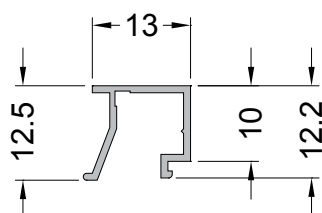

Z-182 (30-068)

0.541 Kg/m

Marco Travessa Liso

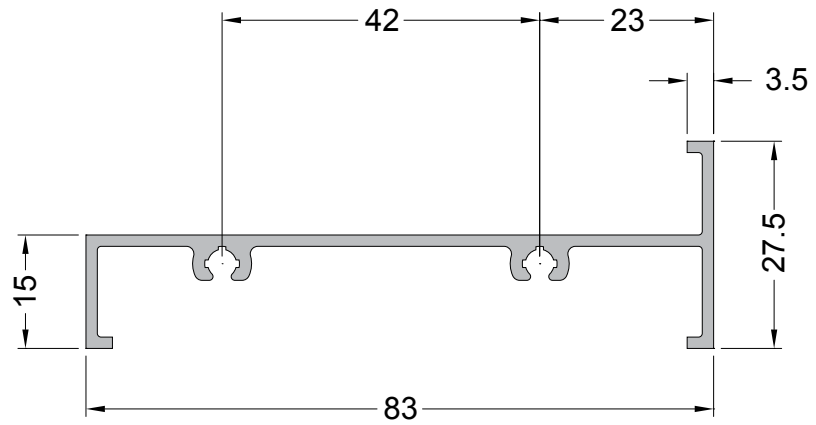

Z-181 (30-089)

0.561 Kg/m

Marco

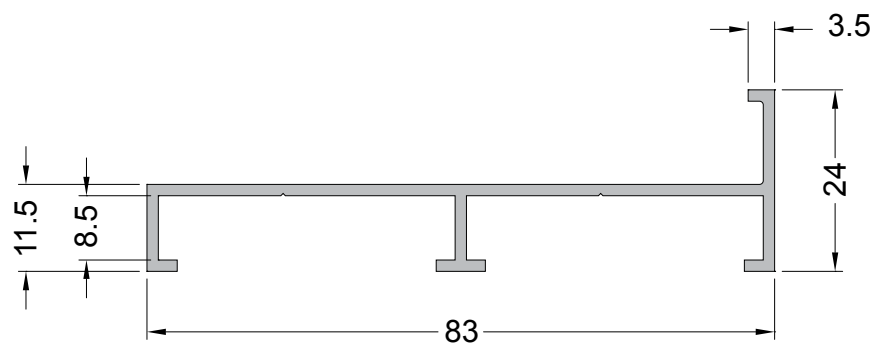

P-258 (30-067)

1.159 Kg/m

Coluna

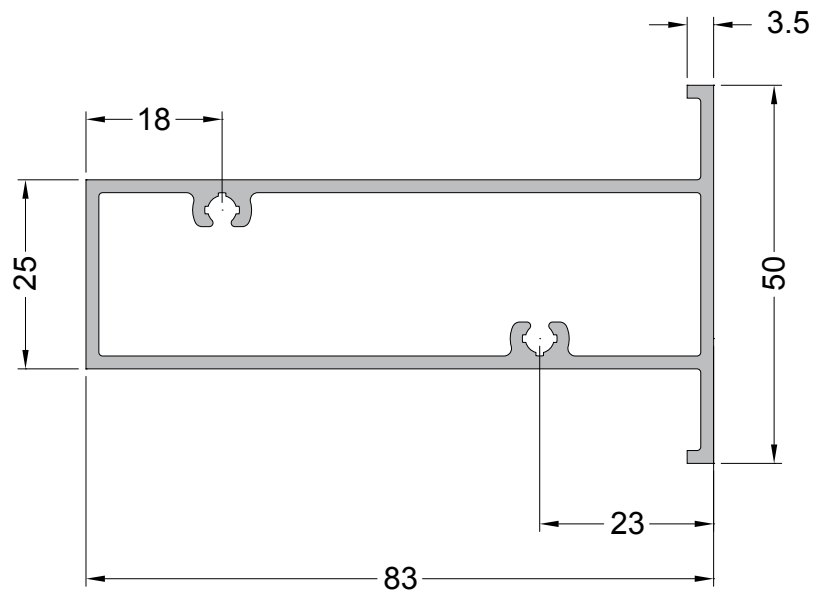

E-492 (30-261)

1.433 Kg/m

Marco Trilho

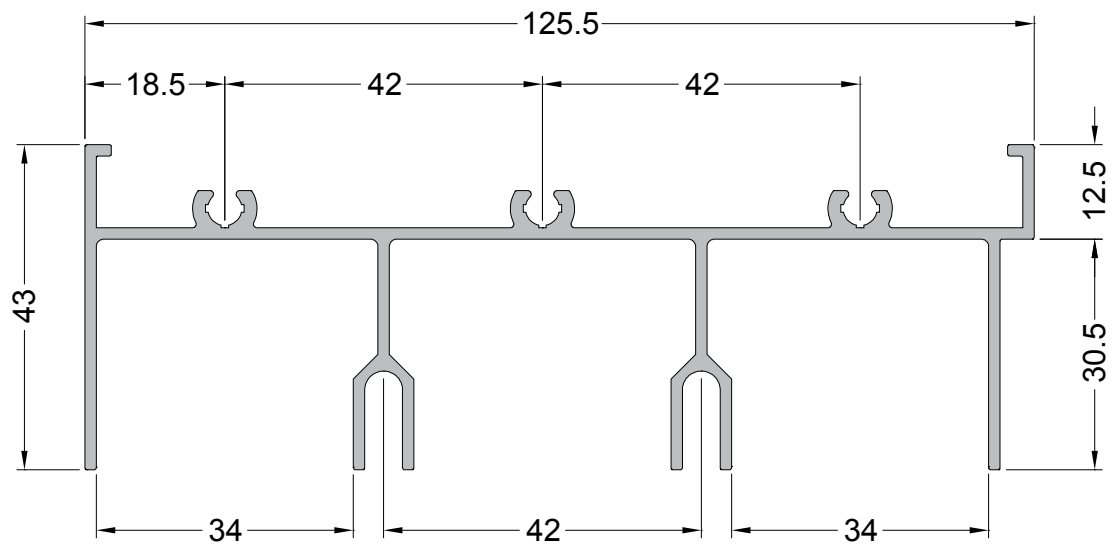

Z-262 (30-253)

0.734 Kg/m

Marco



P-578

1.504 Kg/m

Coluna

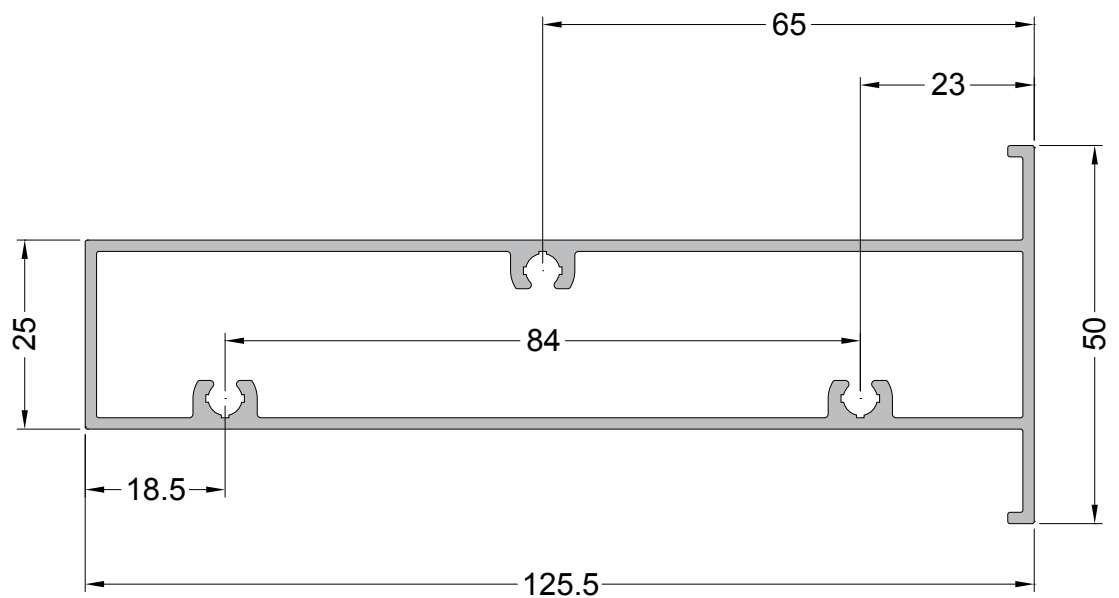

U-462

0.534 Kg/m

Marco

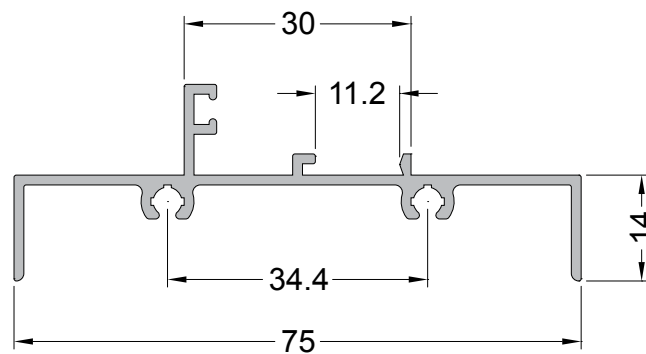

U-461

0.705 Kg/m

Marco

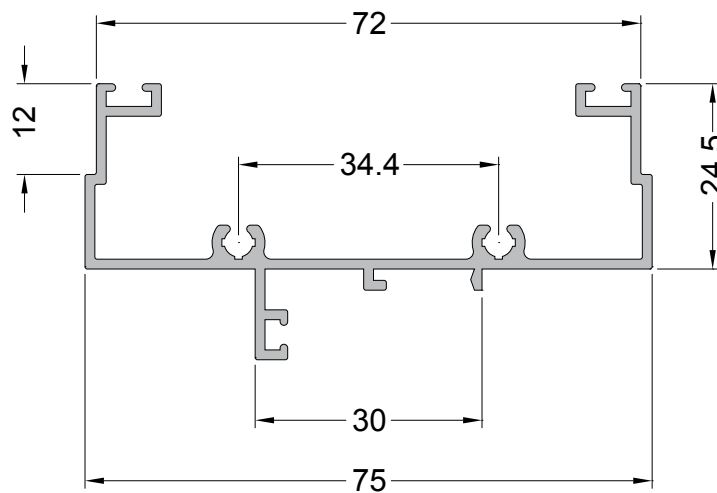

Y-199

0.802 Kg/m

Marco

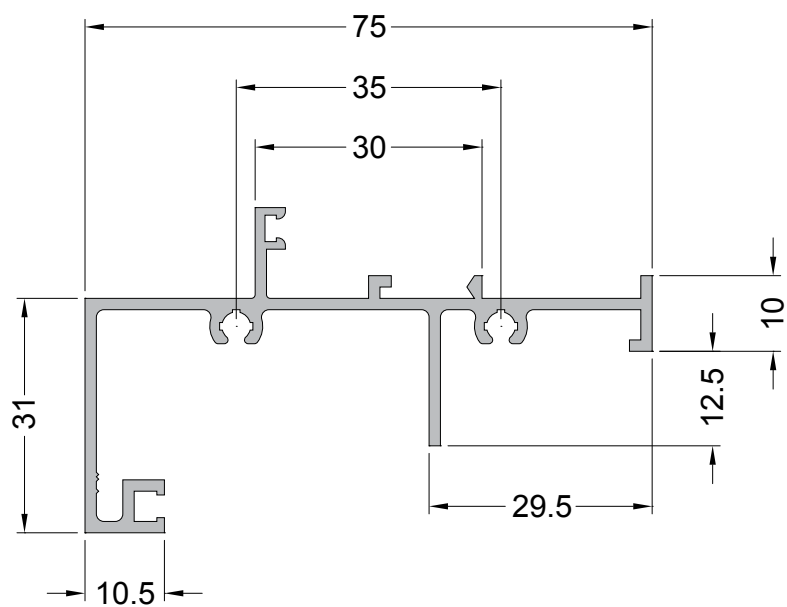

Y-131 (30-001)

0.458 Kg/m

Folha

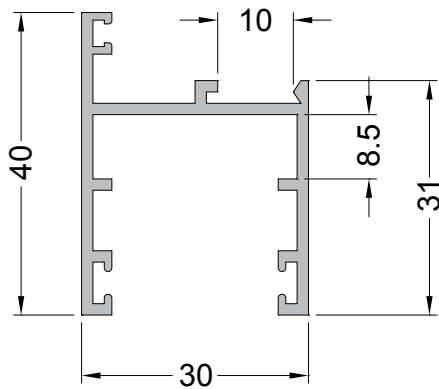

A-030 (30-004)

0.564 Kg/m

Folha

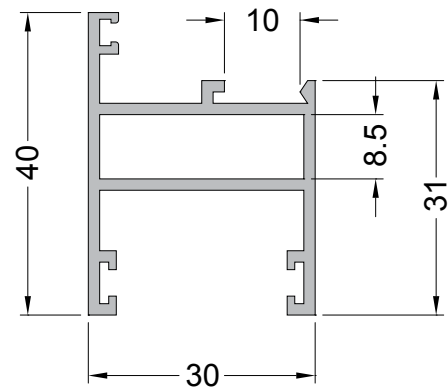

A-026 (30-009)

0.706 Kg/m

Folha

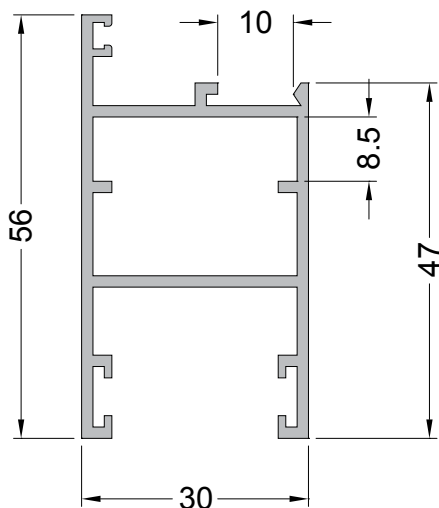

P-075 (30-036)

0.598 Kg/m

Coluna

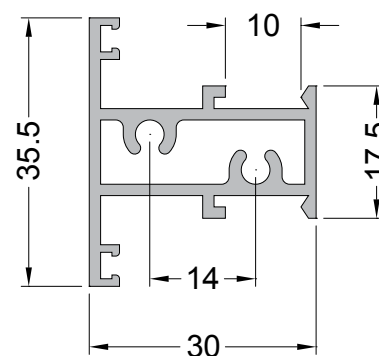

P-078 (30-025)

0.761 Kg/m

Travessa

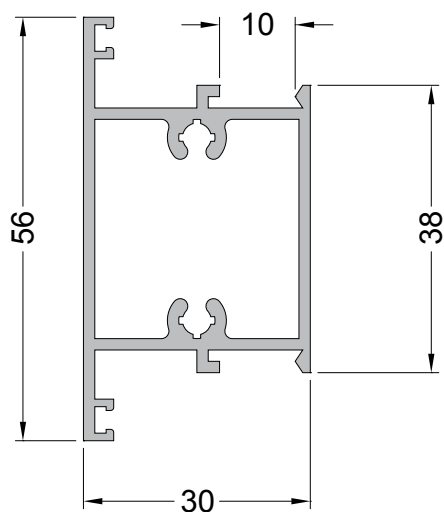

P-165 (30-030)

1.171 Kg/m

Travessa

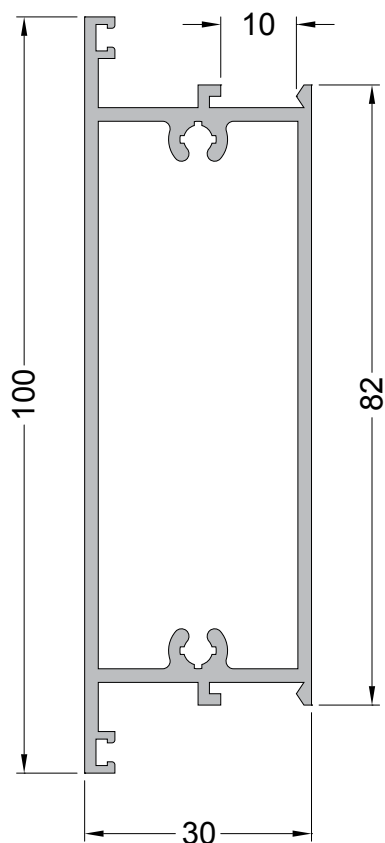

A-081 (30-028)

1.163 Kg/m

Folha

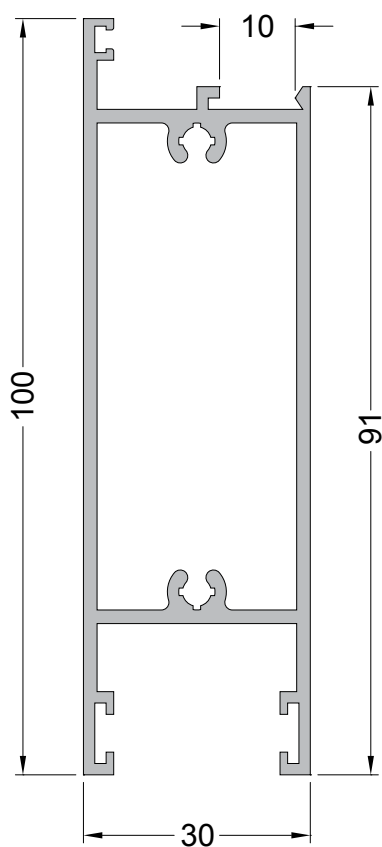

P-269 (30-024)

0.758 Kg/m

Travessa

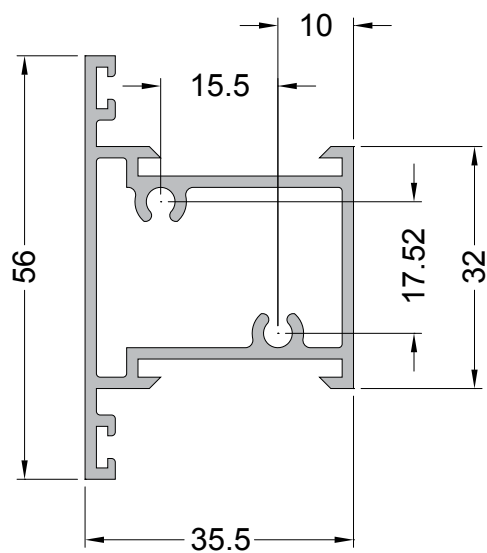

P-084 (30-003)

0.530 Kg/m

Folha

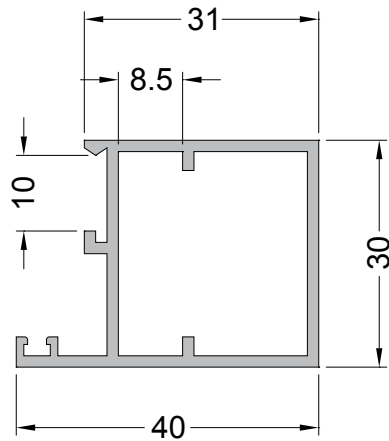

P-068 (30-008)

0.693 Kg/m

Folha

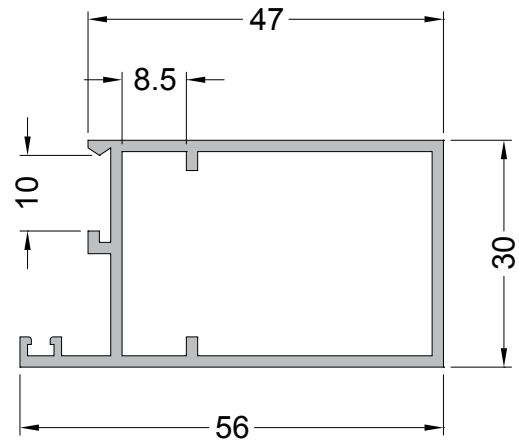

P-281 (30-011)

0.785 Kg/m

Folha

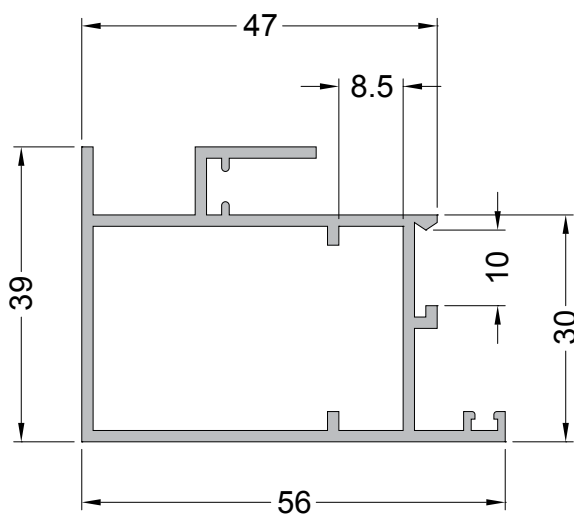

P-282 (30-012)

0.840 Kg/m

Folha

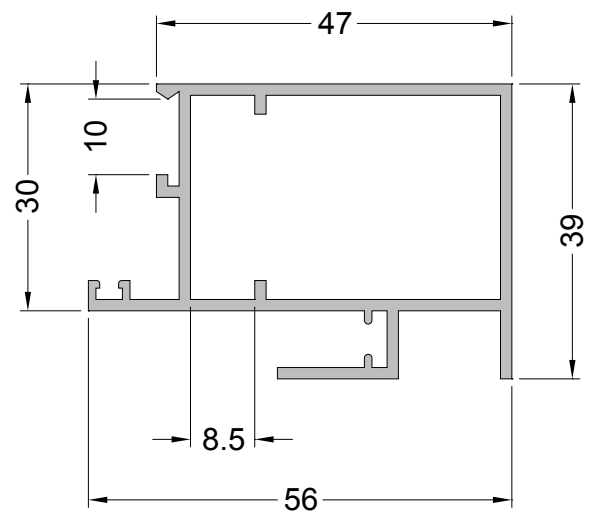



A-041 (30-014)

0.732 Kg/m

Folha

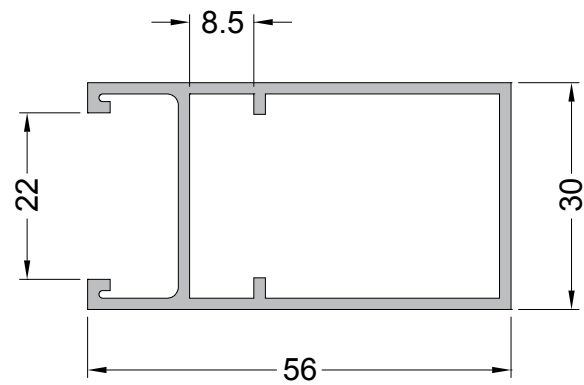

P-358 (30-033)

0.927 Kg/m

Folha

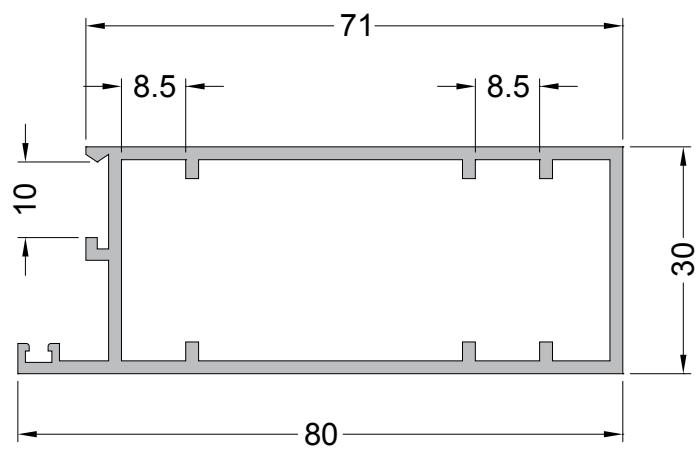

A-046

0.937 Kg/m

Folha

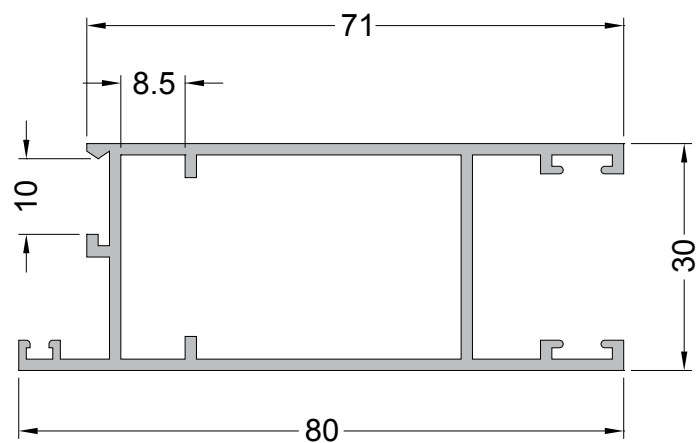

P-273 (30-023)

0.604 Kg/m

Marco

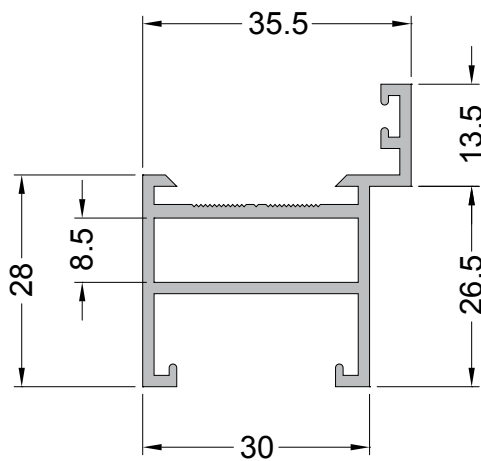

P-272 (30-027)

0.751 Kg/m

Marco

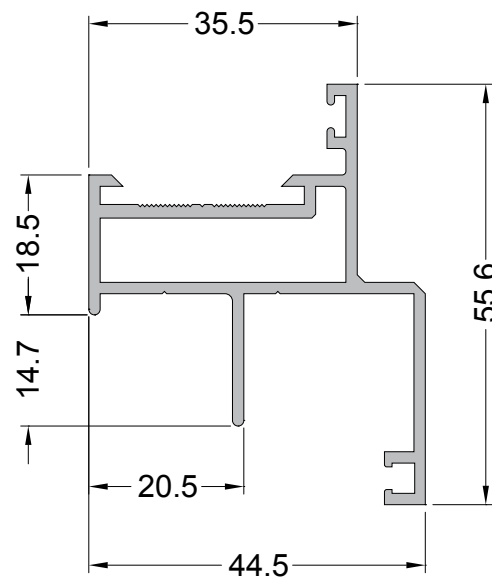

P-417 (30-079)

0.731 Kg/m

Travessa

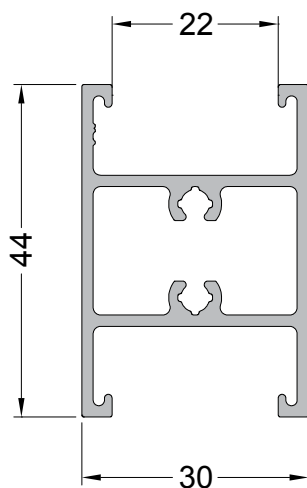

L-519 (30-034)

0.295 Kg/m

Mata Junta

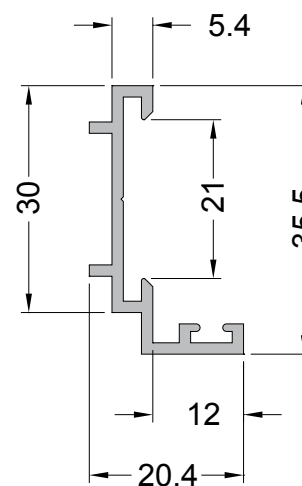

P-270 (30-026)

0.778 Kg/m

Folha

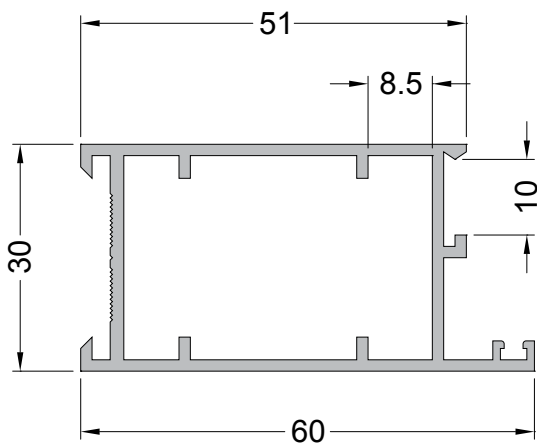

A-144 (30-077)

0.766 Kg/m

Folha

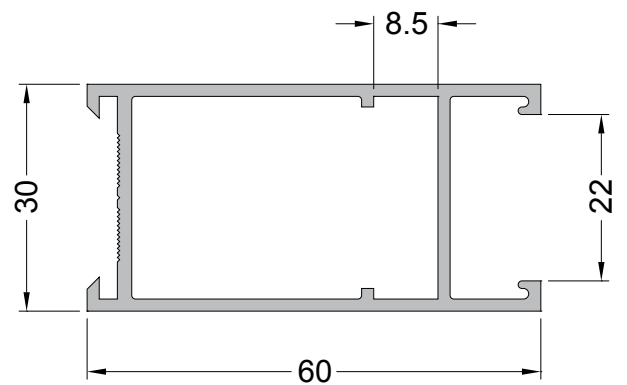

U-482 (BG-010)

0.113 Kg/m

Baguete

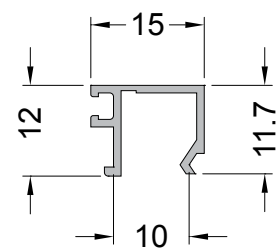

P-264 (30-082)

1.124 Kg/m

Folha

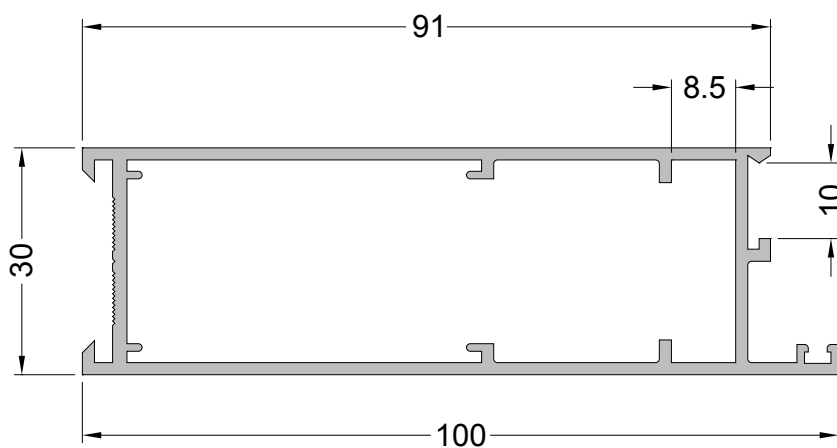

U-679 (BG-009)

0.168 Kg/m

Baguete

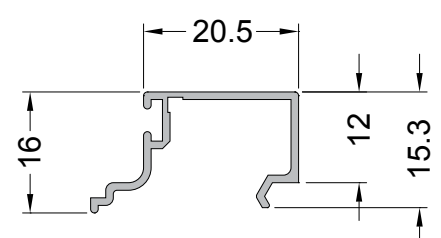

Y-140 (30-054)

0.406 Kg/m

Marco

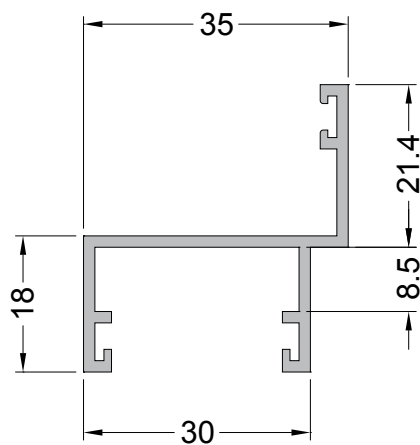

Y-214 (30-048)

0.595 Kg/m

Marco

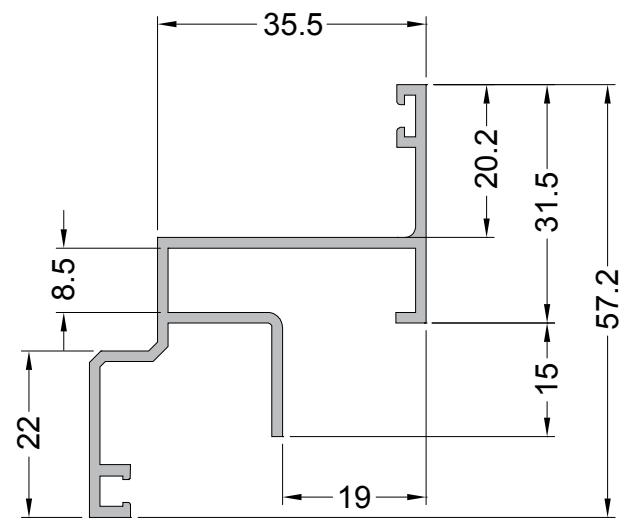

P-419 (30-235)

0.753 Kg/m

Travessa

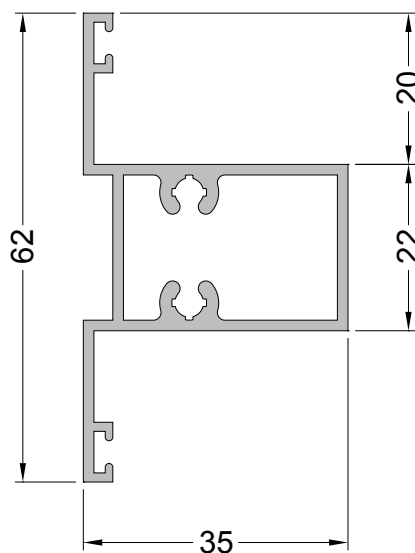

Y-346 (30-084)

0.499 Kg/m

Marco

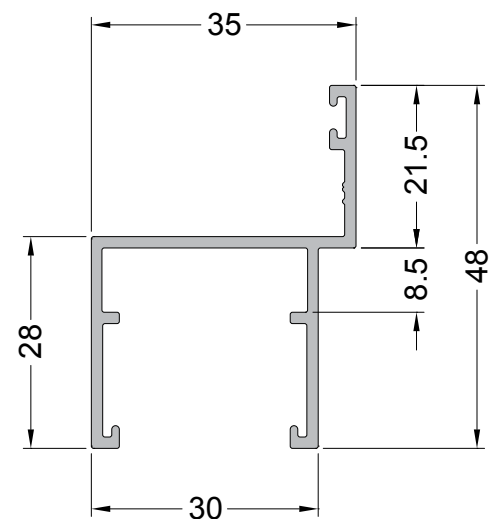

P-120 (30-049)

0.528 Kg/m

Folha

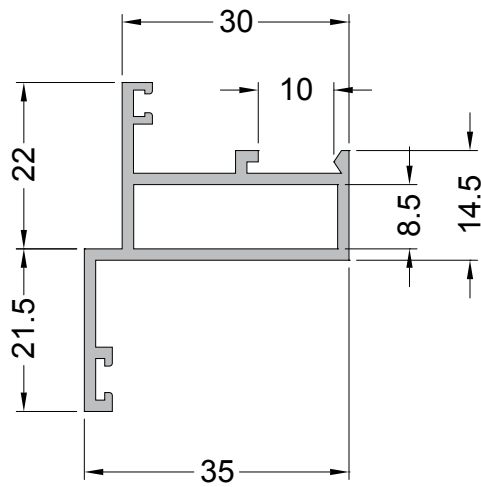

P-121 (30-050)

0.522 Kg/m

Folha

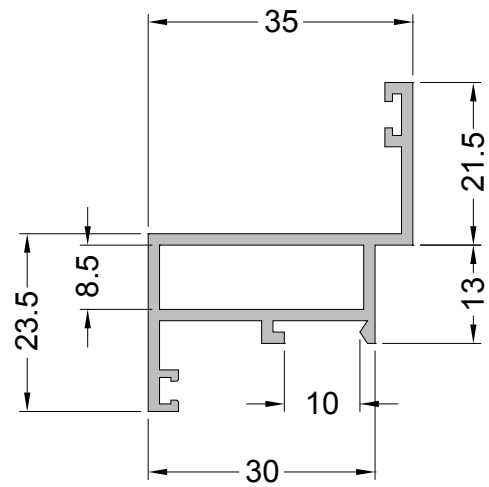

P-064 (30-051)

0.398 Kg/m

Folha

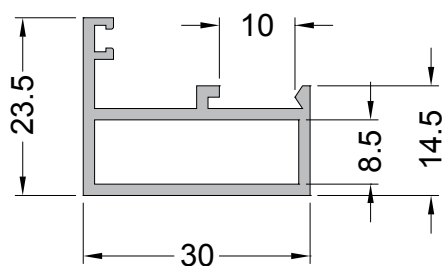

Y-113 (30-052)

0.338 Kg/m

Fixo

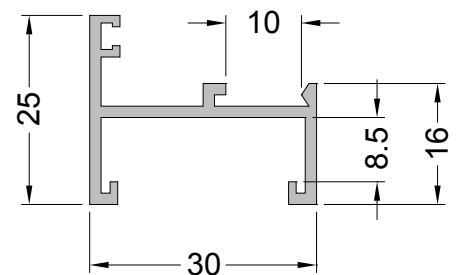

A-209 (30-270)

0.463 Kg/m

Complemento

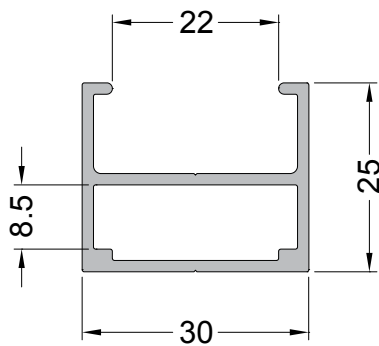

Y-148 (30-056)

0.330 Kg/m

Batedeira

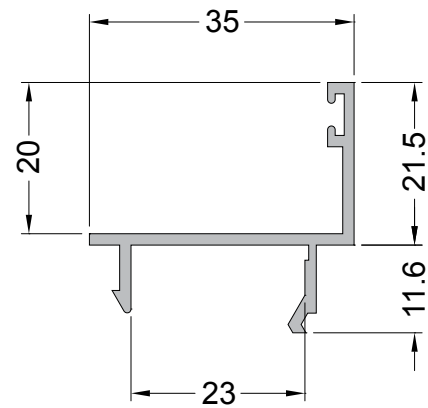

Z-118 (30-039)

0.624 Kg/m

Marco

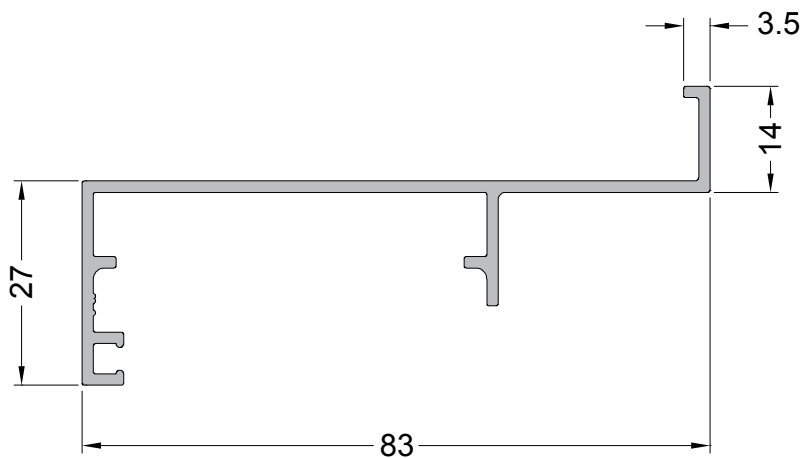

E-150 (30-019)

0.298 Kg/m

Mata Junta

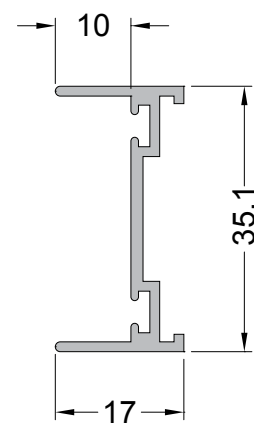

Z-082

0.341 Kg/m

Trilho

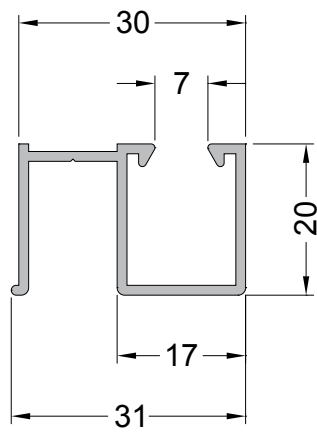

E-287 (42-001)

1.032 Kg/m

Marco Trilho Individual

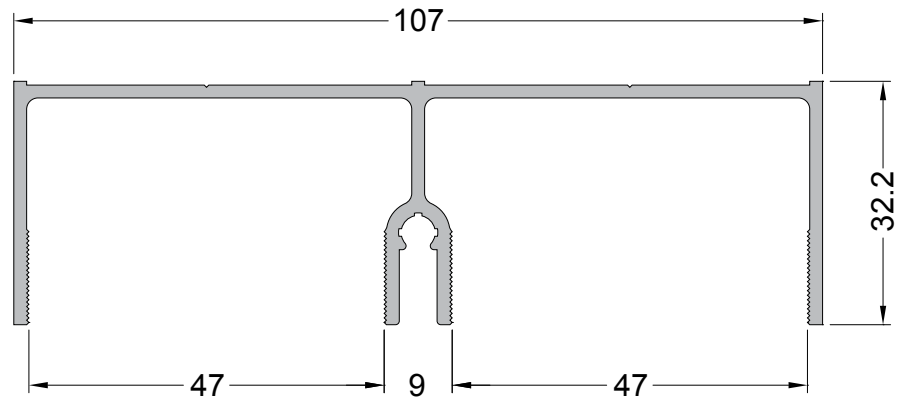

Y-350 (CL-016)

1.046 Kg/m

Marco Travessa Liso

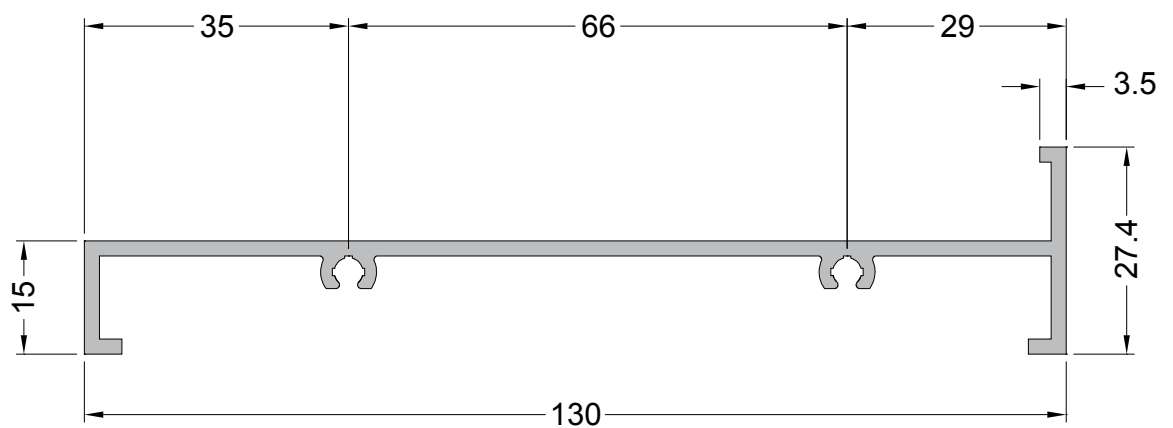

Z-265 (42-002)

1.048 Kg/m

Marco Trilho Inferior

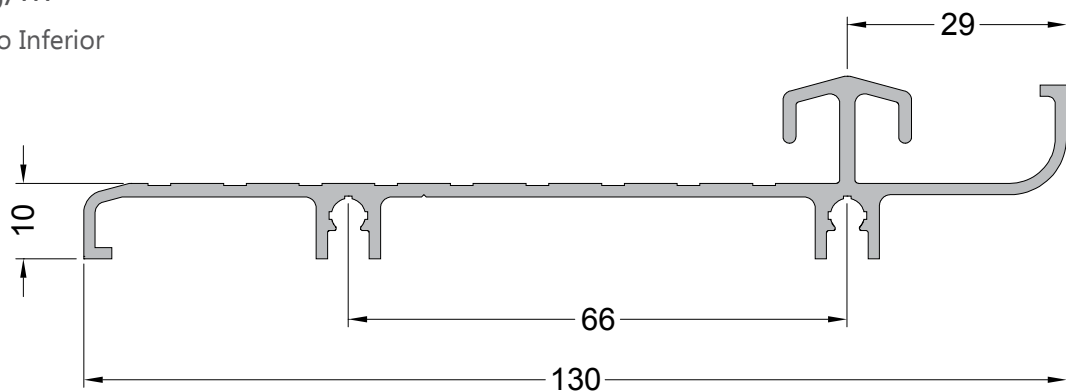



P-278 (CC-023)

2.179 Kg/m

Coluna

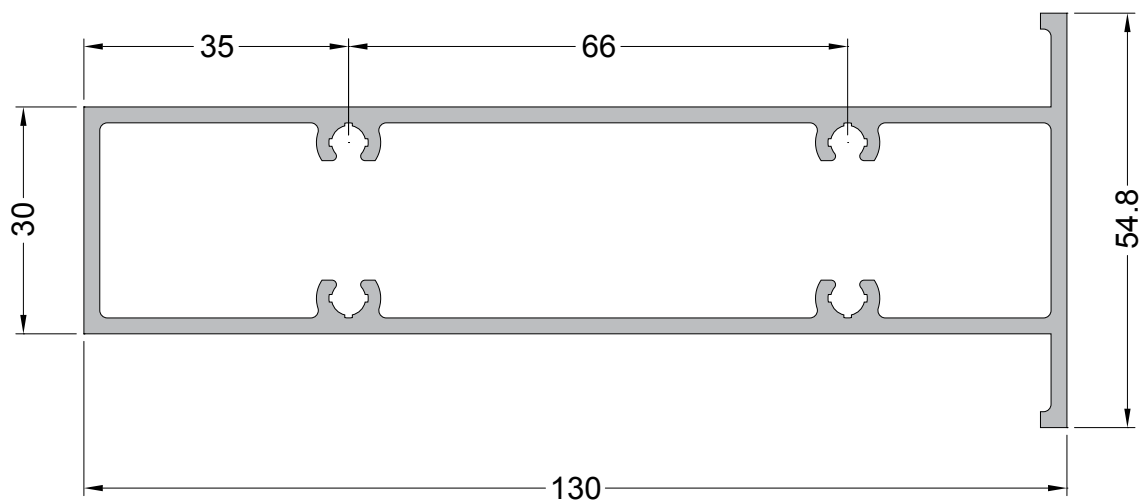

A-103 (42-006)

1.577 Kg/m

Folha

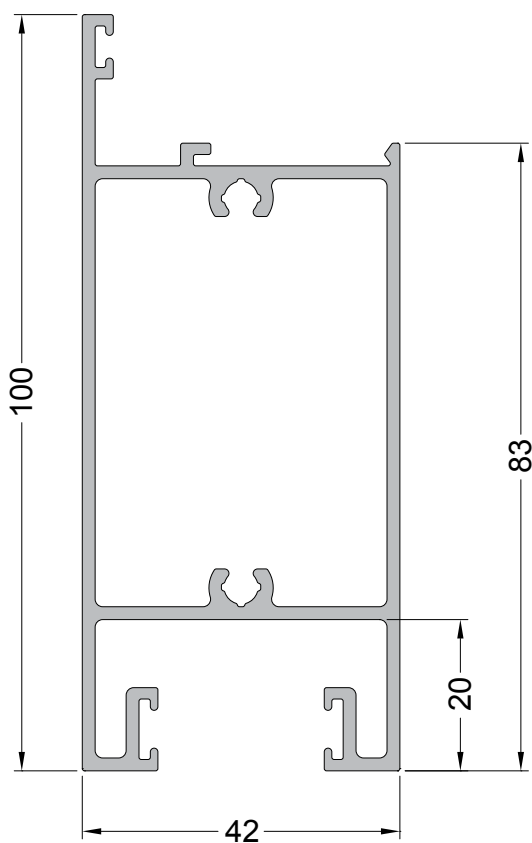

P-279 (42-007)

1.331 Kg/m

Travessa

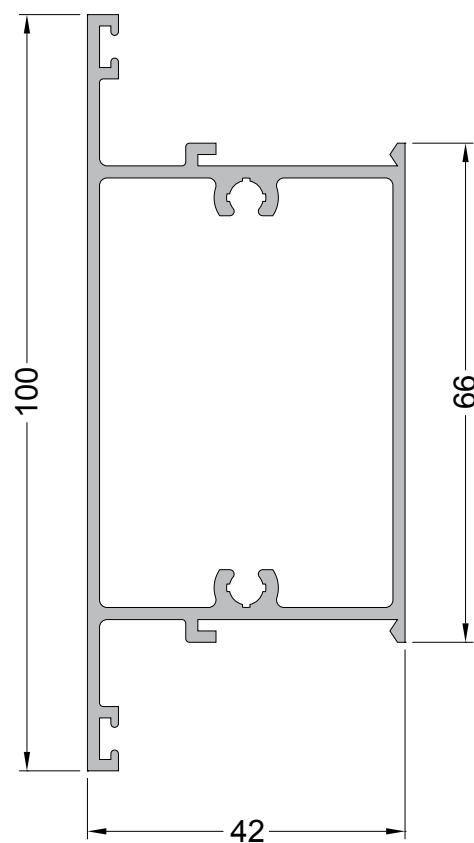

P-194 (42-025)

0.883 Kg/m

Travessa

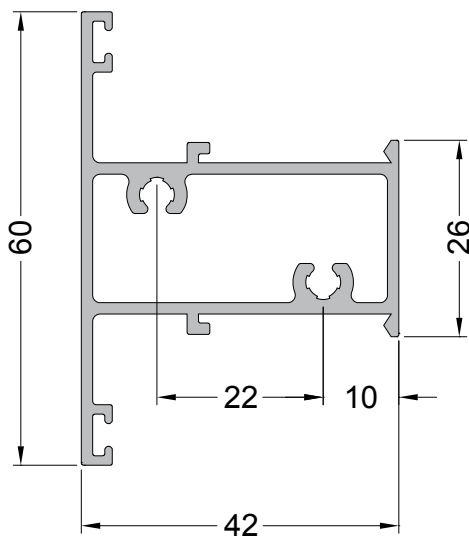

CX-3205

1.068 Kg/m

Folha

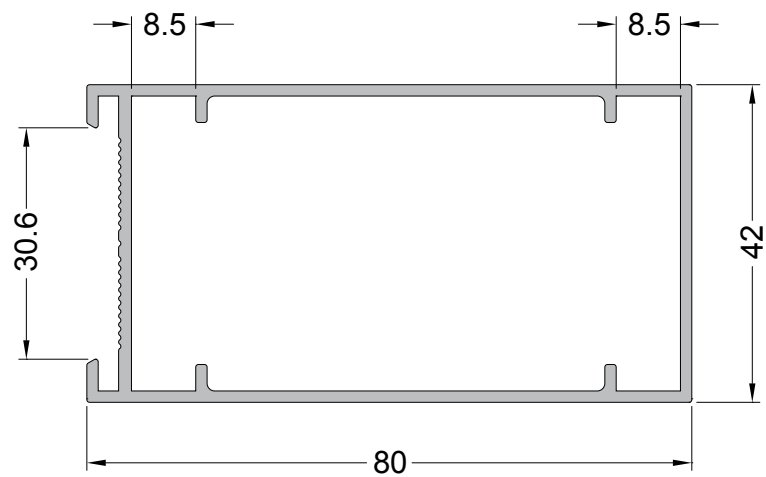

A-104

0.878 Kg/m

Folha

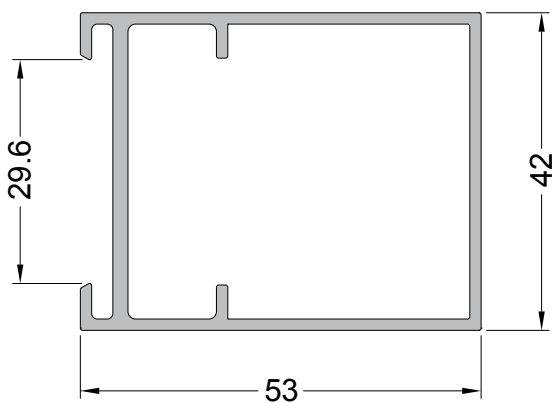

42-061

1.135 Kg/m

Folha

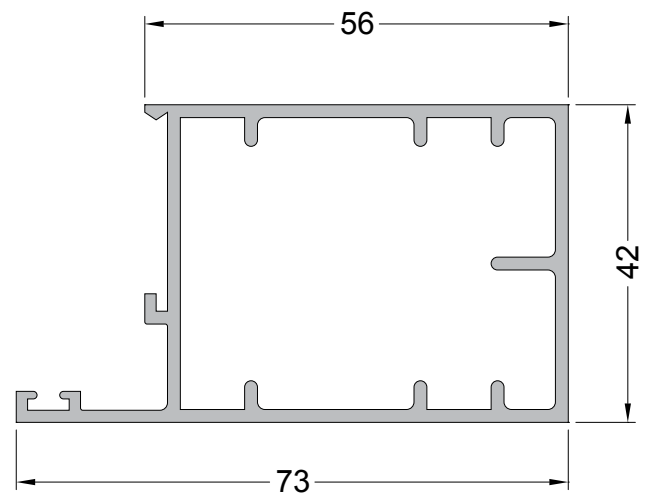

42-062

1.292 Kg/m

Folha

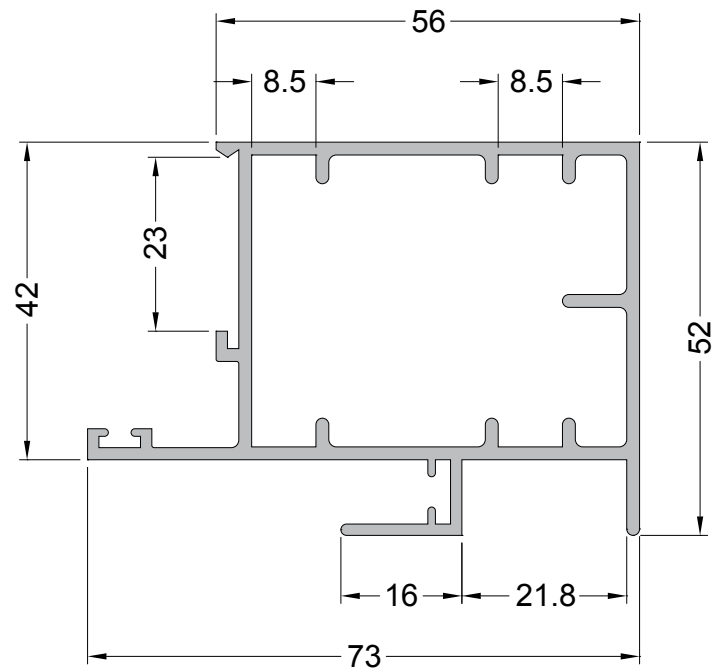

42-063

1.292 Kg/m

Folha

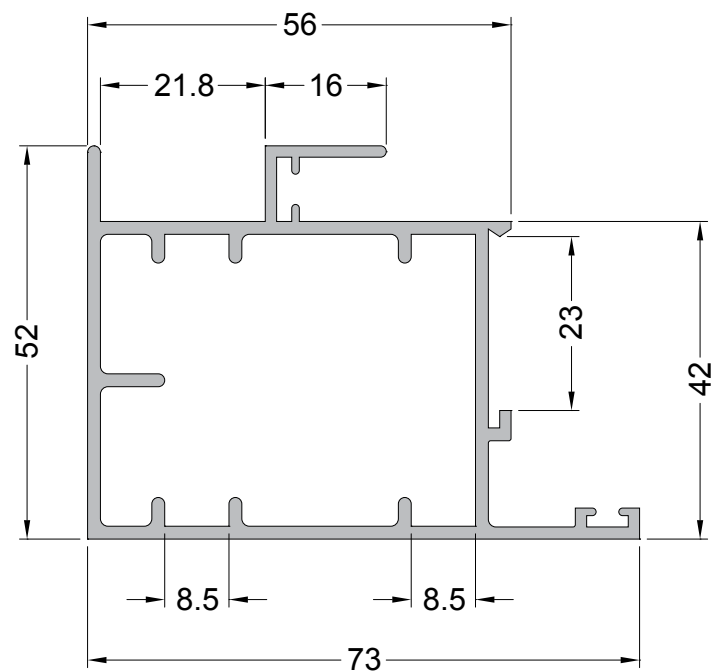

P-280 (42-012)

0.807 Kg/m

Marco

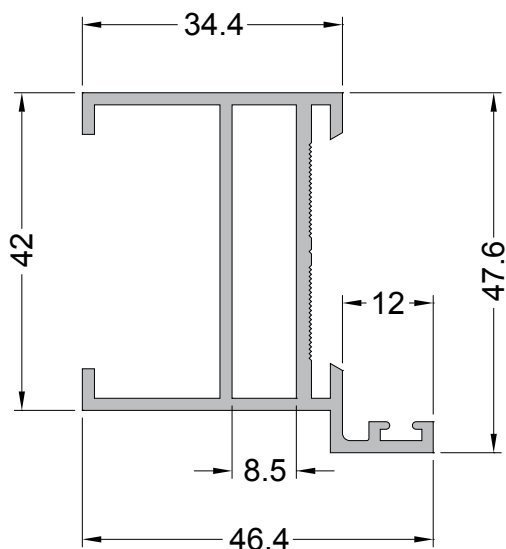

42-035

1.156 Kg/m

Folha

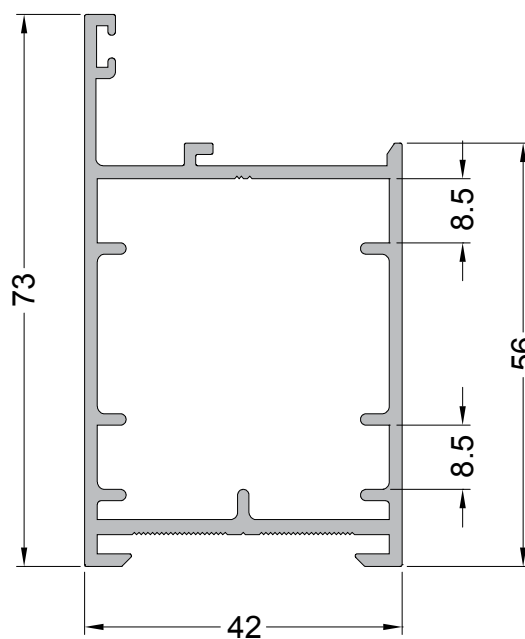

42-032

1.356 Kg/m

Folha

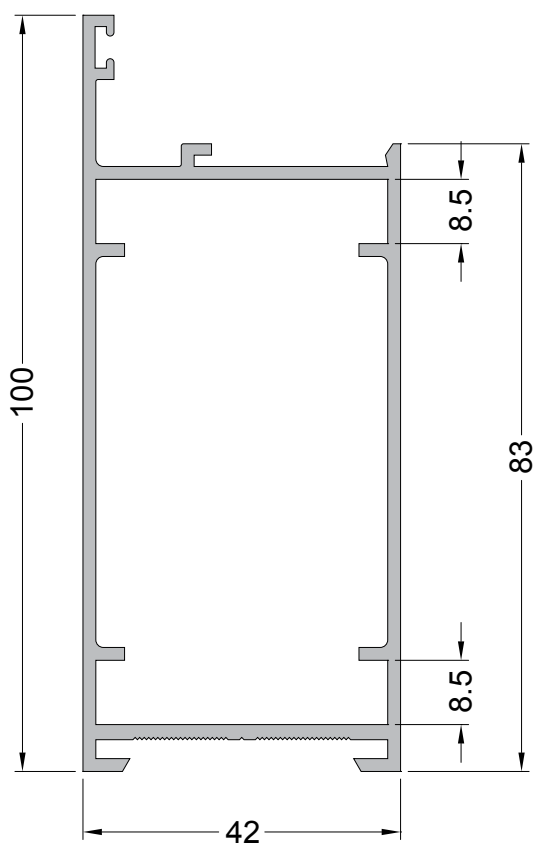

L-521 (42-014)

0.368 Kg/m

Mata Junta

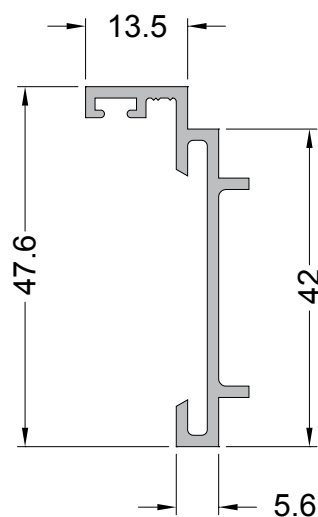

Y-181

0.523 Kg/m

Marco

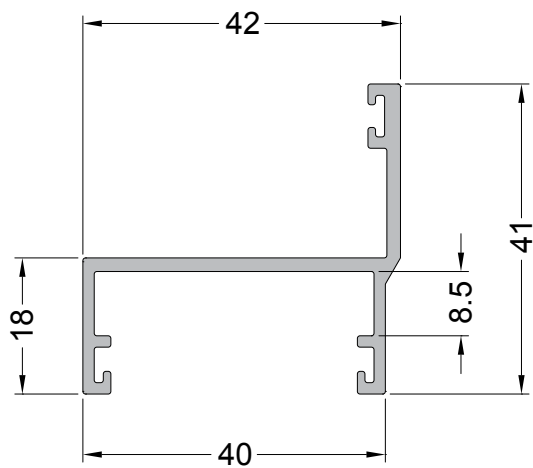

P-418

0.739 Kg/m

Folha

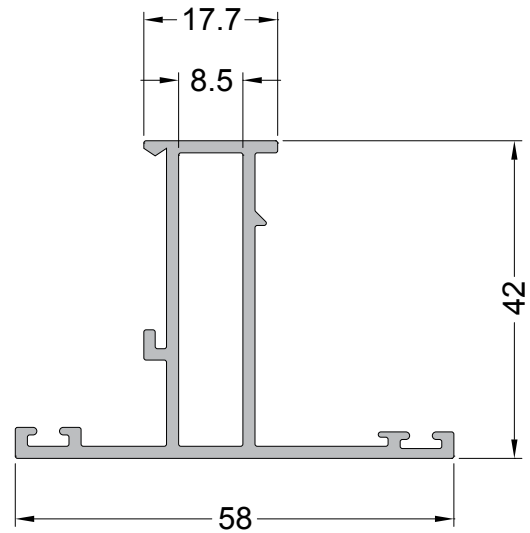

Y-351

0.439 Kg/m

Fixo

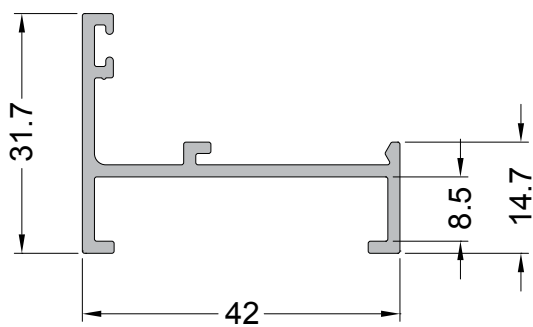

P-253 (42-023)

0.581 Kg/m

Folha

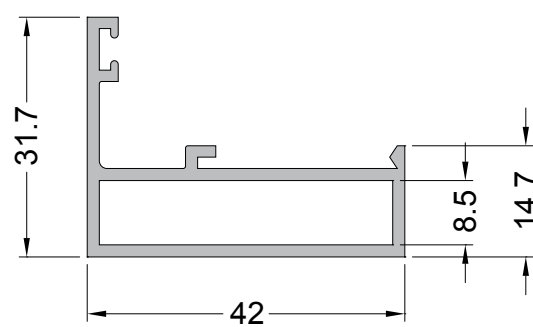

Y-271 (42-026)

0.593 Kg/m

Fixo

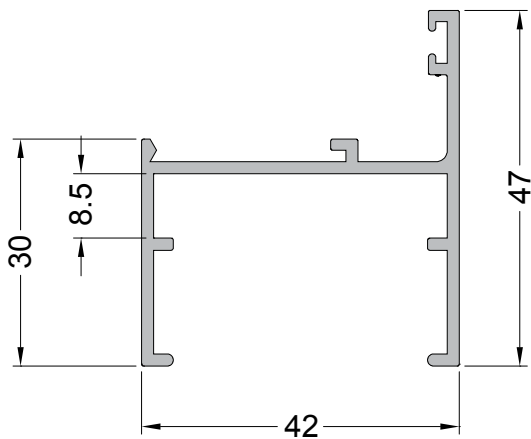

U-611 (BG-021)

0.209 Kg/m

Baguete

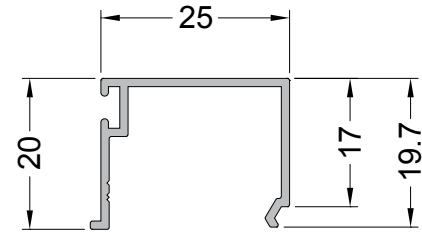

U-1076 (BG-037)

0.192 Kg/m

Baguete

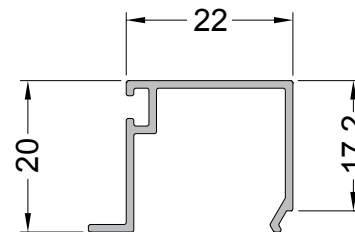

L-473 (BG-036)

0.165 Kg/m

Baguete

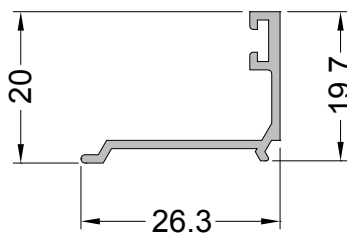

U-696 (BG-023)

0.200 Kg/m

Baguete

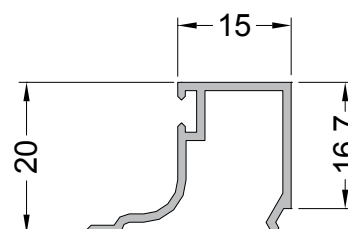

MB-009

0.175 Kg/m

Mata Junta

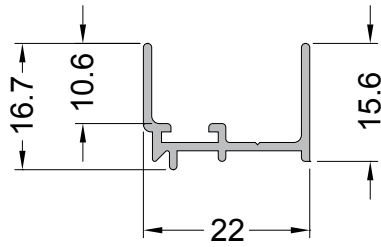

MB-011

0.341 Kg/m

Folha

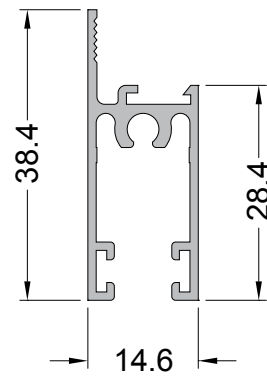

MP-357  
0.570 Kg/m  
Marco Trilho Superior

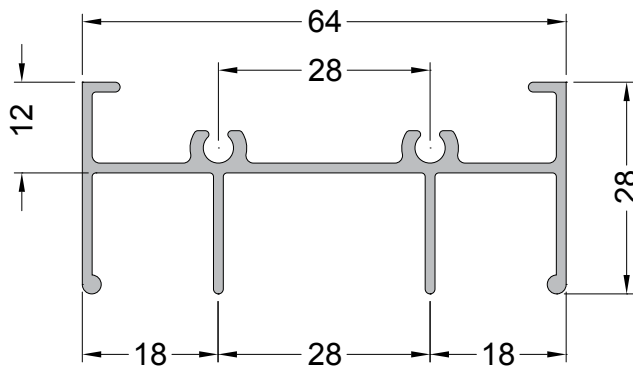

MP-415  
0.610 Kg/m  
Marco Trilho Inferior

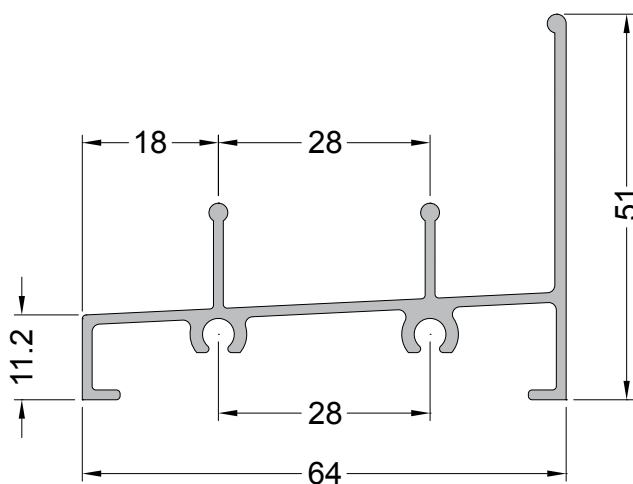

MP-409  
0.793 Kg/m  
Marco Trilho Inferior

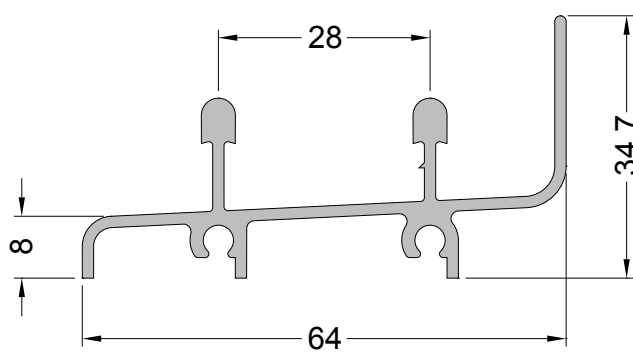



MP-404

0.820 Kg/m

Marco Trilho Inferior

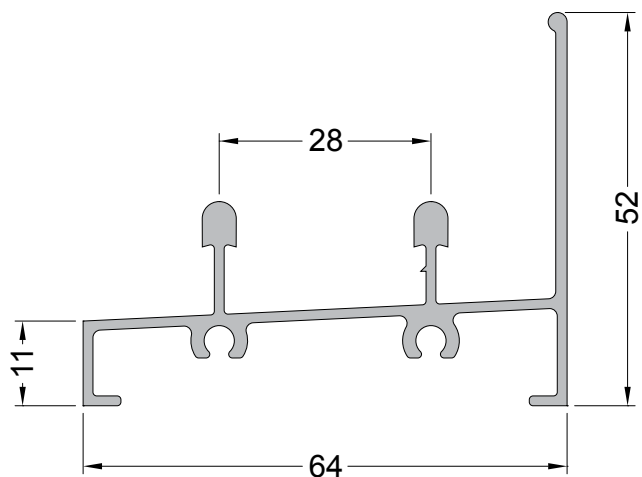

MP-344

0.947 Kg/m

Marco Trilho Superior

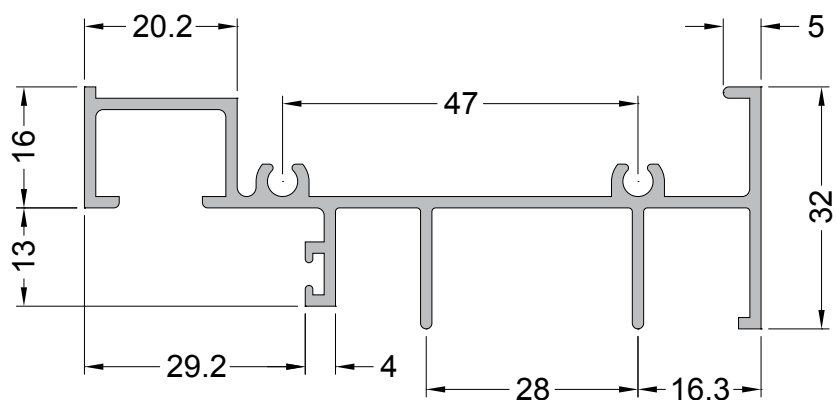

MP-406

1.173 Kg/m

Marco Trilho Inferior

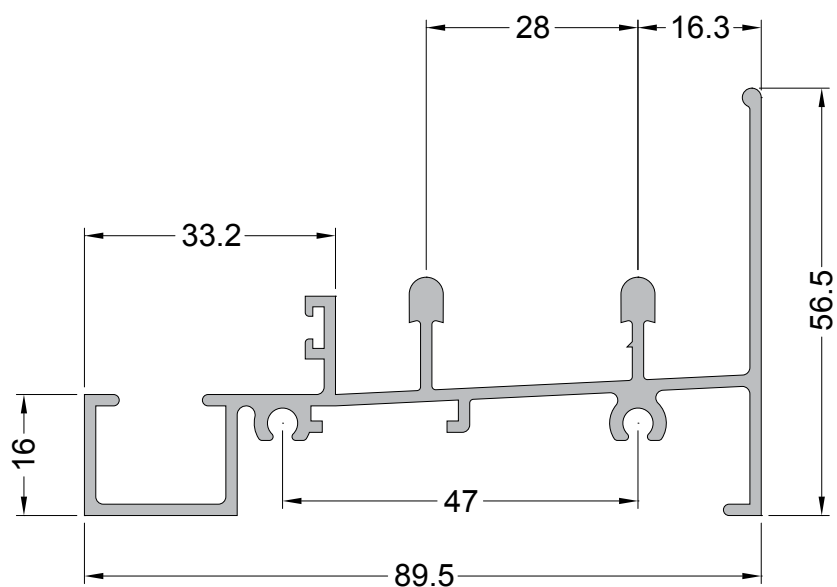

MP-363  
0.542 Kg/m  
Marco Travessa

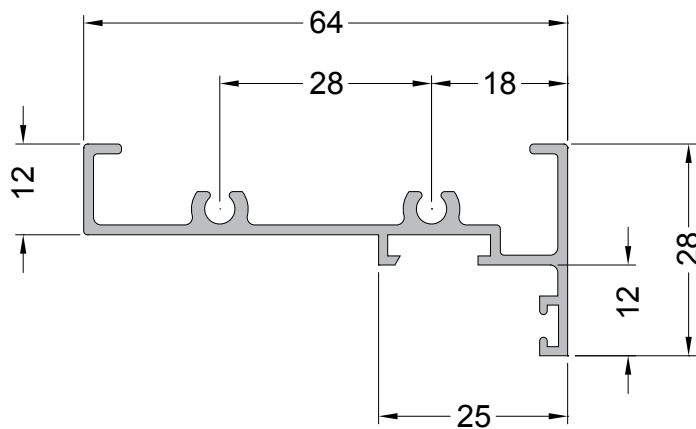

MP-361  
1.087 Kg/m  
Marco Trilho Interm. Superior

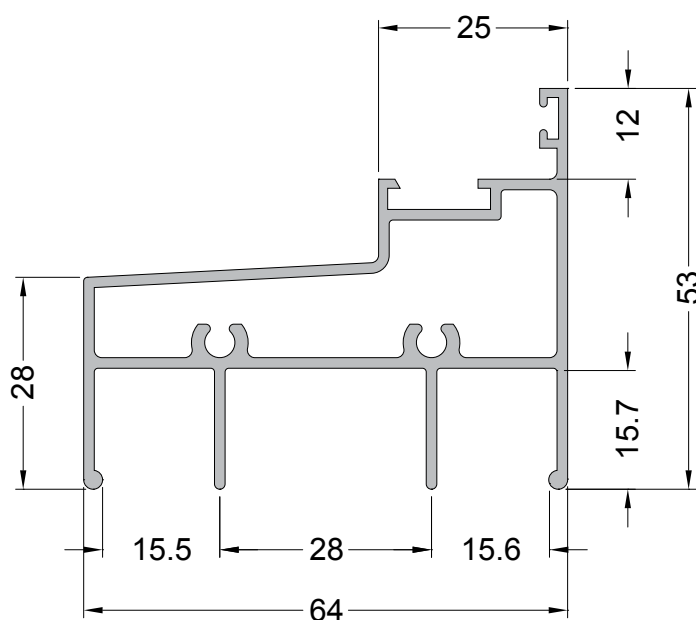

MP-405  
1.024 Kg/m  
Marco Trilho Interm. Inferior

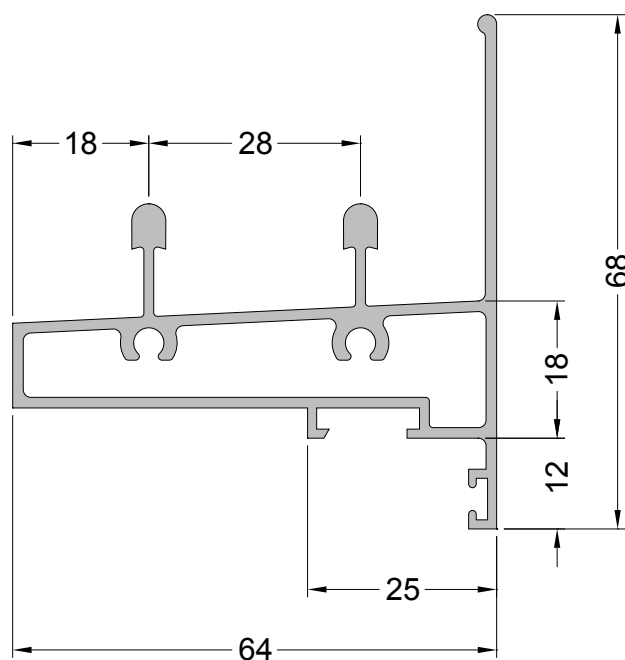

MP-389

0.477 Kg/m

Marco Travessa Liso

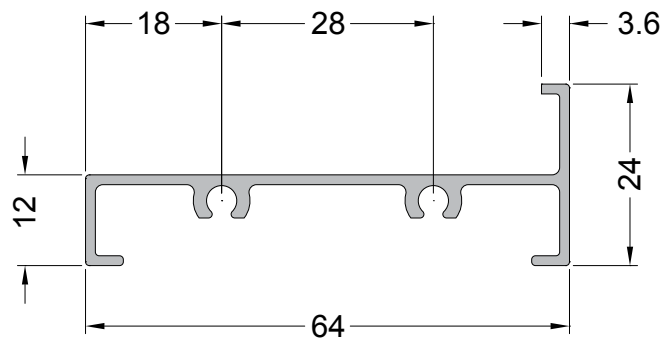

MP-397

0.379 Kg/m

Marco

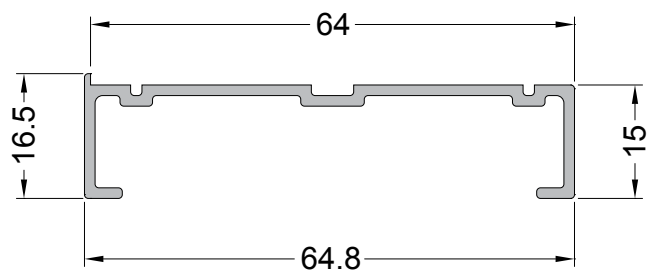

MP-360

0.442 Kg/m

Marco

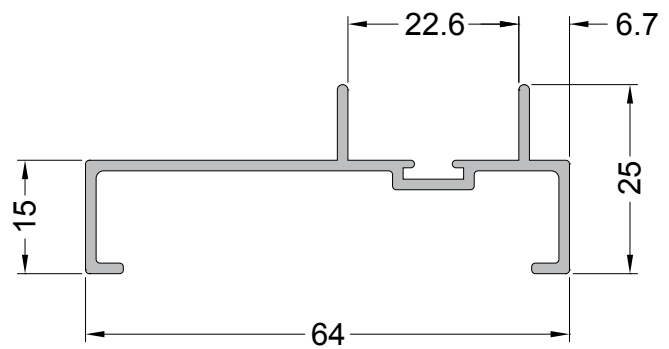

MP-345  
0.710 Kg/m  
Marco

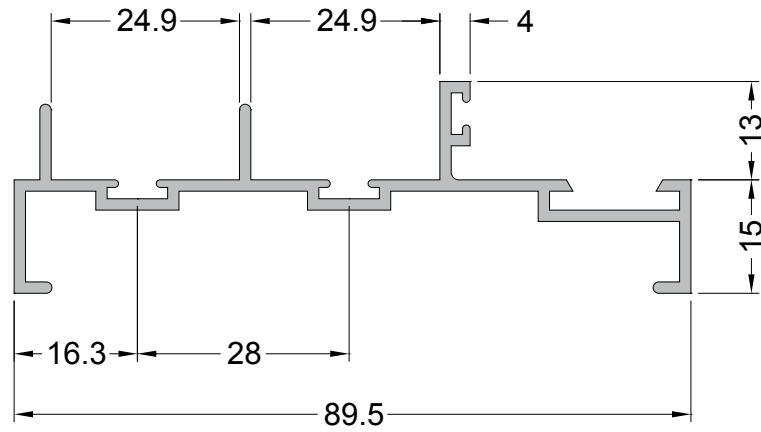

MP-352  
0.200 Kg/m  
Mata Junta

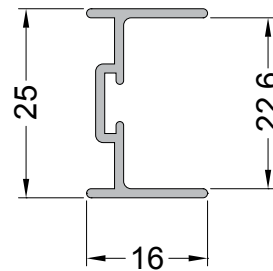

MP-366  
0.877 Kg/m  
Marco Trilho Superior

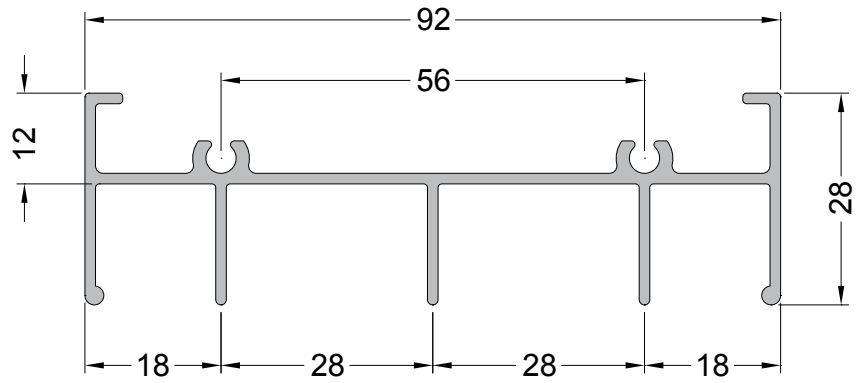

MP-416  
0.827 Kg/m  
Marco Trilho Inferior

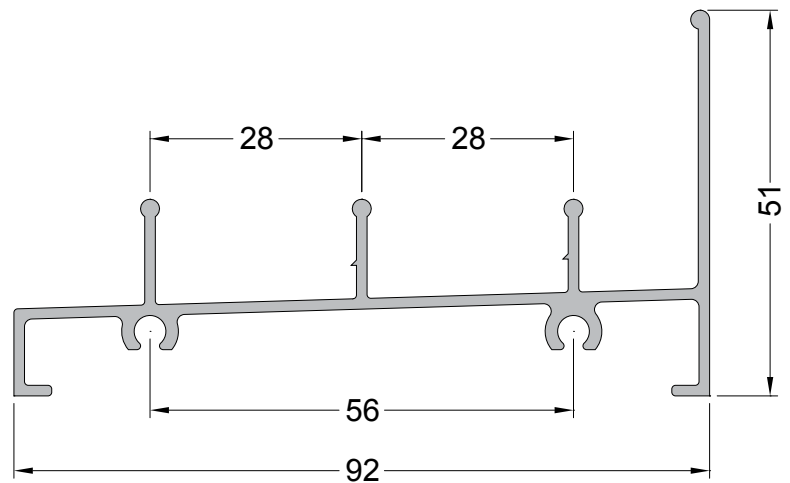

MP-407  
1.028 Kg/m  
Marco Trilho Inferior

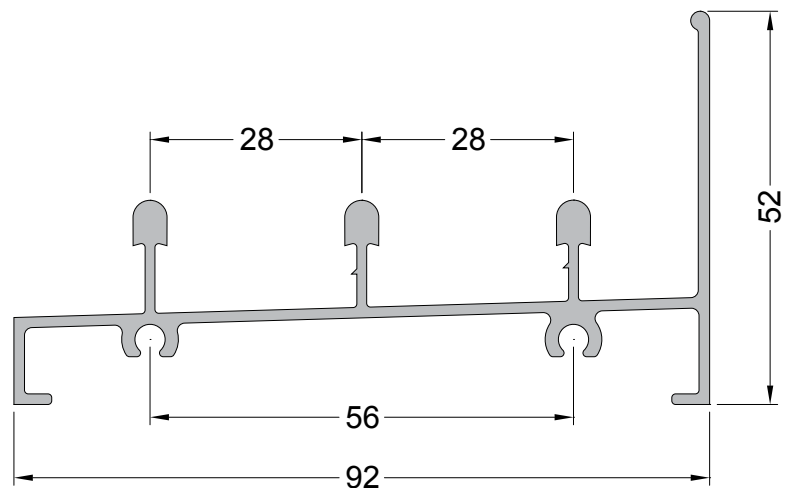

MP-395  
0.528 Kg/m  
Marco

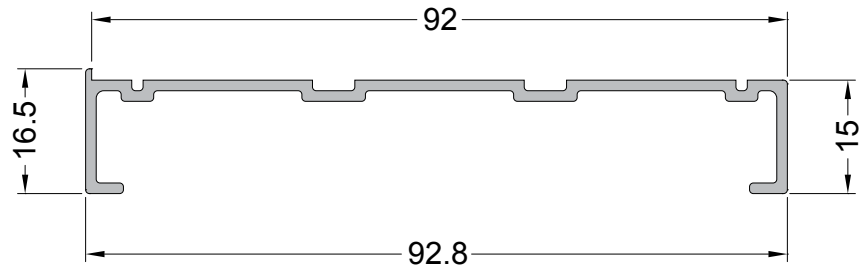

MP-368  
0.678 Kg/m  
Marco

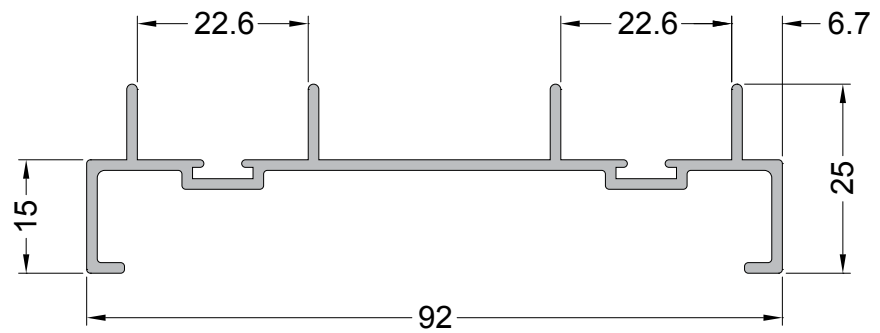

MP-369  
0.583 Kg/m  
Marco

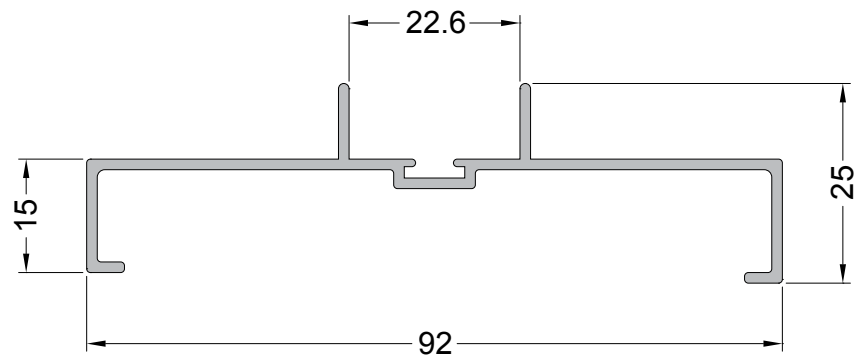

MP-309  
0.426 Kg/m  
Folha

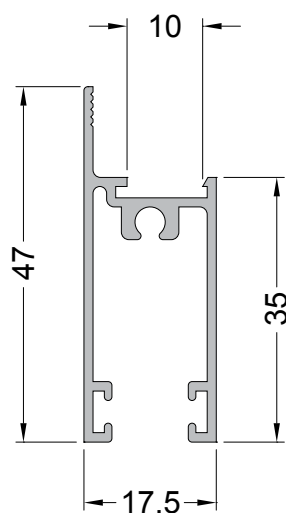

MP-332  
0.580 Kg/m  
Travessa

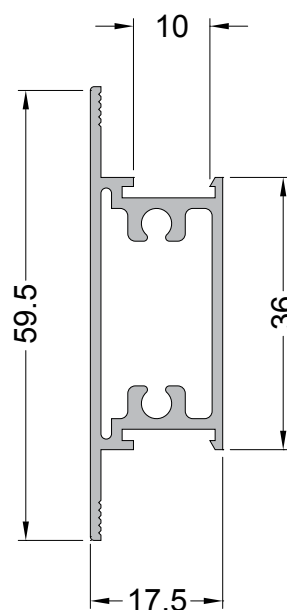

MP-354  
0.983 Kg/m  
Folha

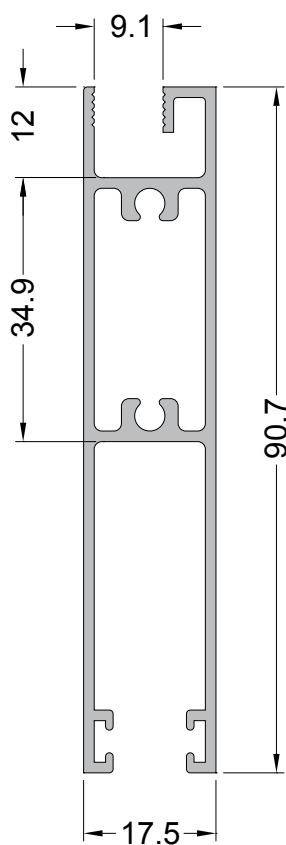

MP-378  
0.356 Kg/m  
Folha

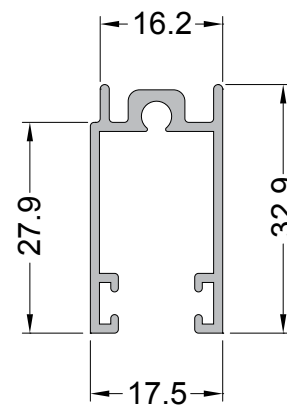

MP-300  
0.361 Kg/m  
Folha

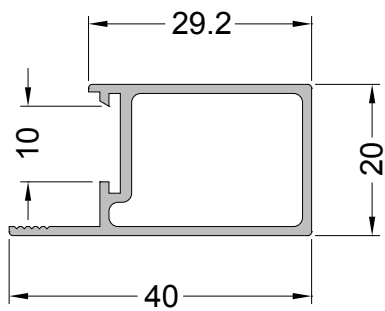

MP-373  
0.401 Kg/m  
Folha

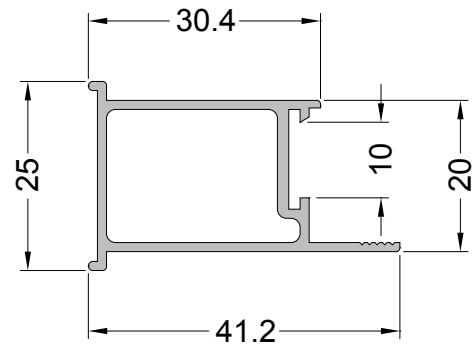

MP-374  
0.577 Kg/m  
Folha

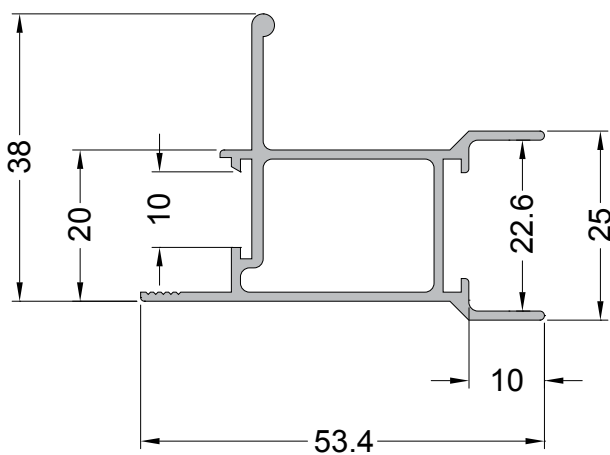

MP-372  
0.458 Kg/m  
Folha

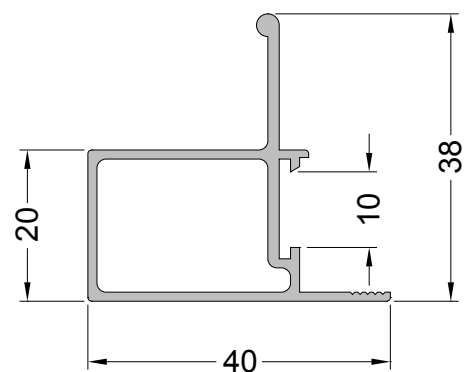



MP-321

0.468 Kg/m

Folha

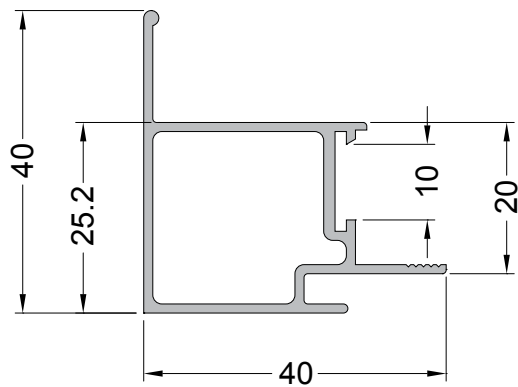

MP-302

0.442 Kg/m

Folha

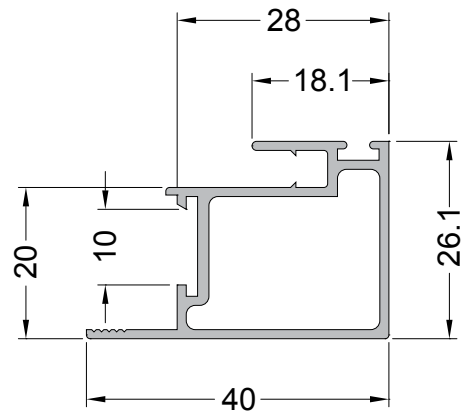

MP-336

0.463 Kg/m

Folha

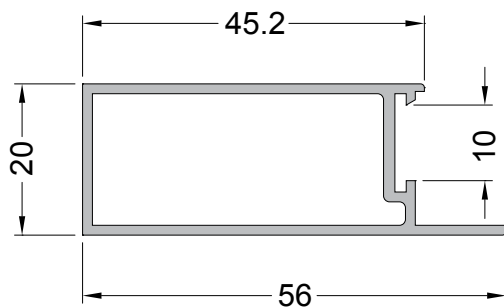

BG-202

0.113 Kg/m

Baguete

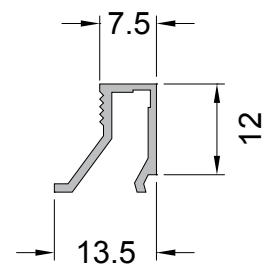

MP-305  
0.368 Kg/m  
Folha

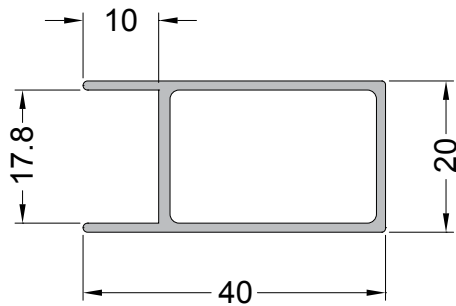

MP-303  
0.450 Kg/m  
Folha

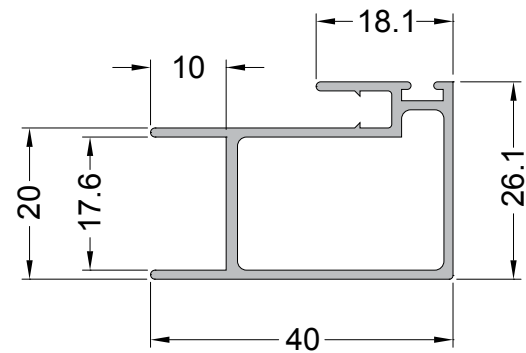

MP-379  
0.924 Kg/m  
Folha

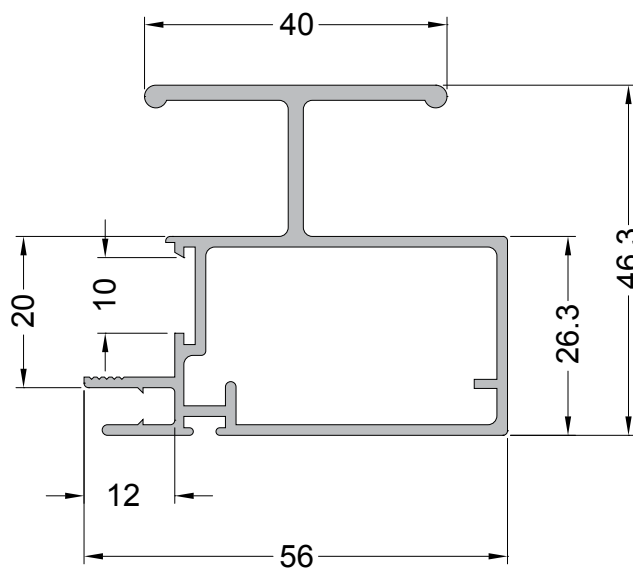

MP-073  
0.105 Kg/m  
Porta Palheta

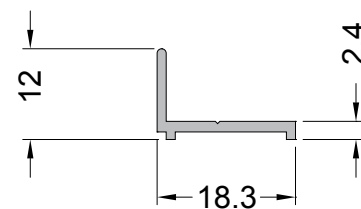

ME-011  
0.887 Kg/m  
Marco Superior

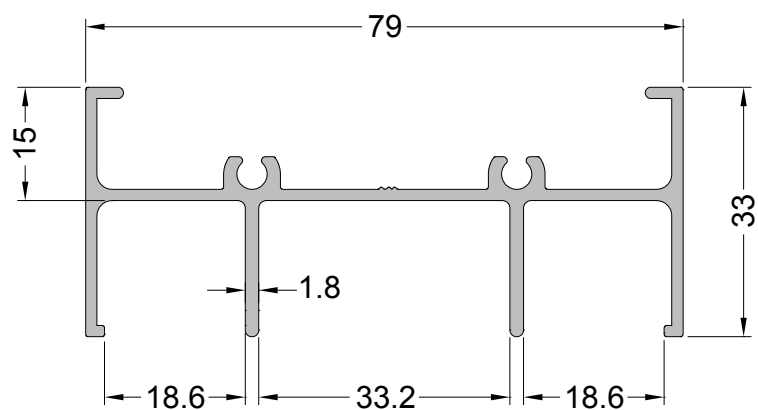

ME-178  
0.532 Kg/m  
Folha

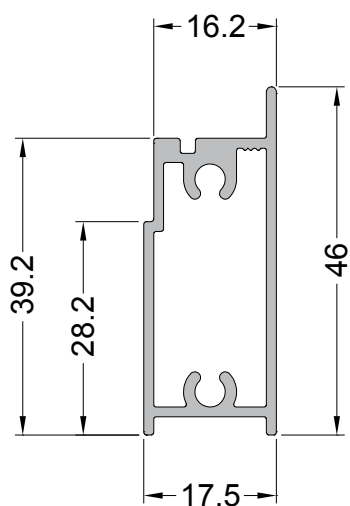

ME-072  
0.336 Kg/m  
Folha

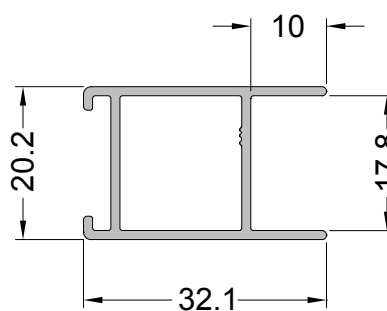

ME-071  
0.368 Kg/m  
Folha

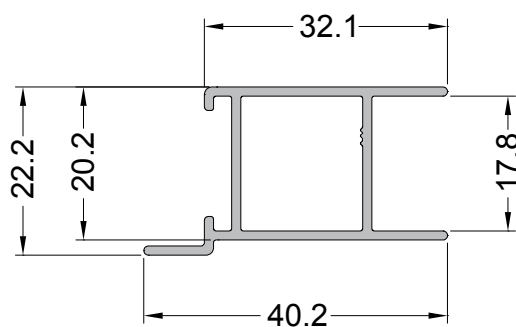

ME-078  
1.128 Kg/m  
Folha

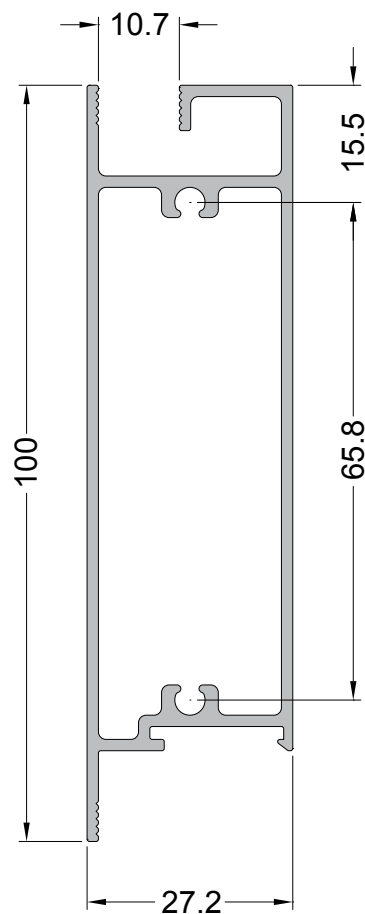

ME-075  
0.763 Kg/m  
Folha

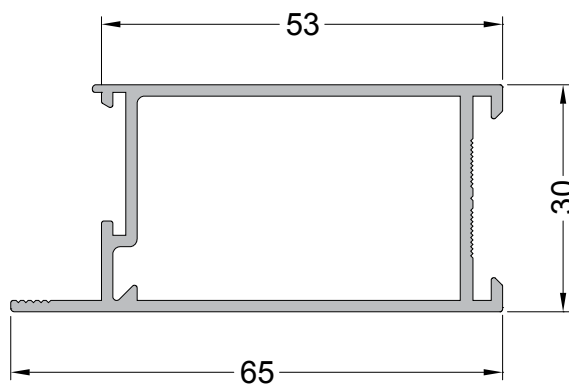

25-311  
0.336 Kg/m  
Marco

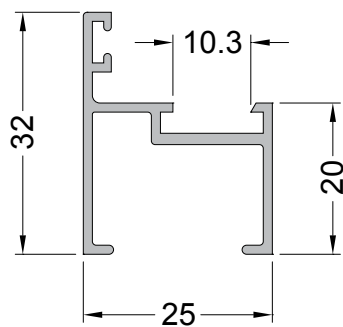

25-312  
0.336 Kg/m  
Marco

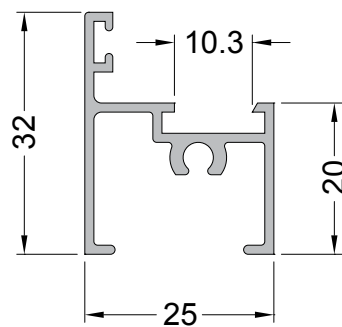

MM-376  
0.500 Kg/m  
Coluna

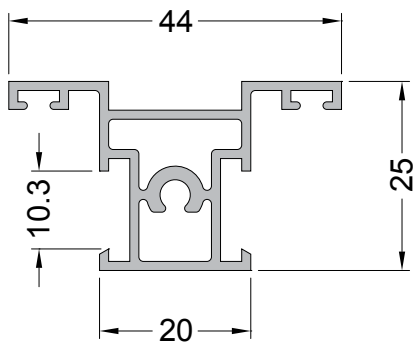

25-308  
0.459 Kg/m  
Coluna

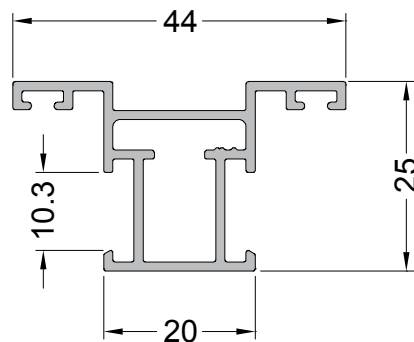

ME-056  
0.197 Kg/m  
Pingadeira

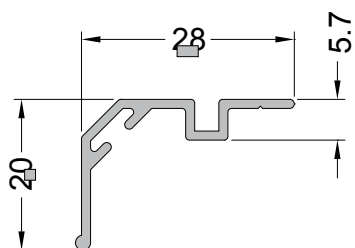

MM-375  
0.417 Kg/m  
Folha

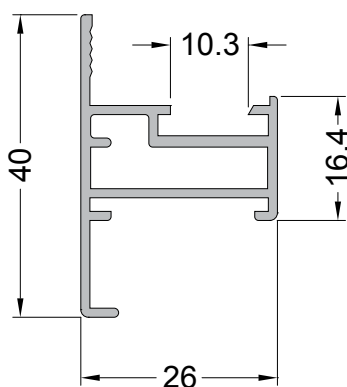

25-315  
0.434 Kg/m  
Folha

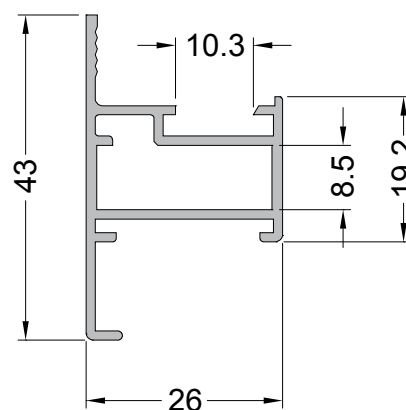

25-301  
0.347 Kg/m  
Folha

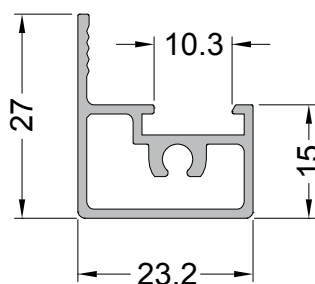

BG-035  
0.118 Kg/m  
Bague

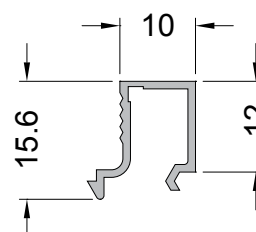

MN-001

1.377 Kg/m

Marco Superior

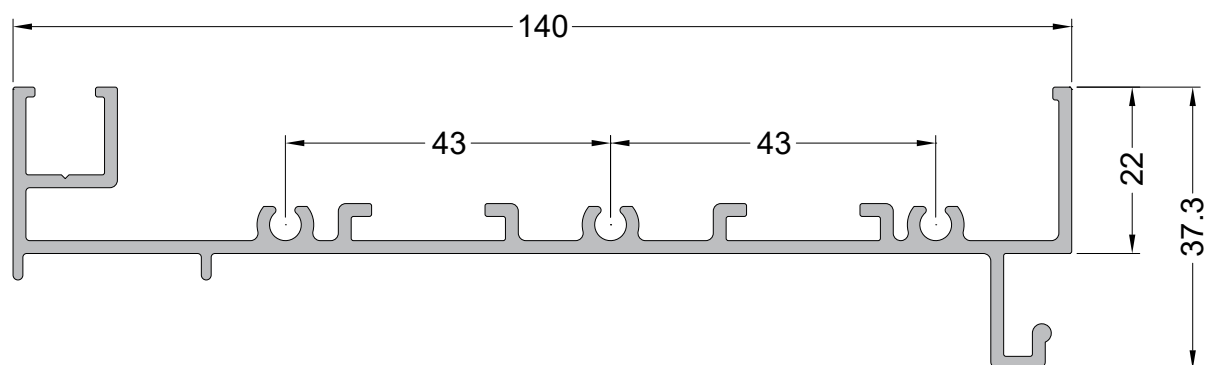

MN-049 (ALG-940)

1.312 Kg/m

Marco Intermediário

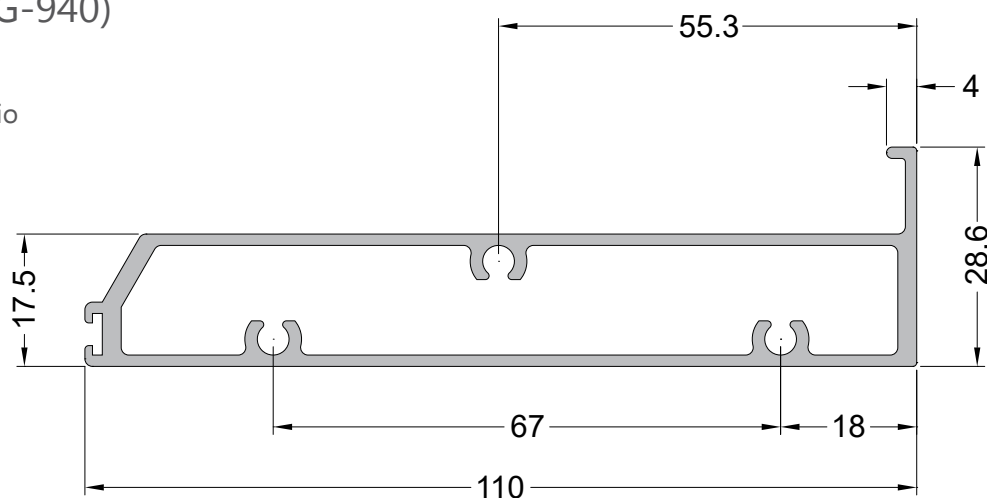

MN-023

0.688 Kg/m

Marco Intermediário

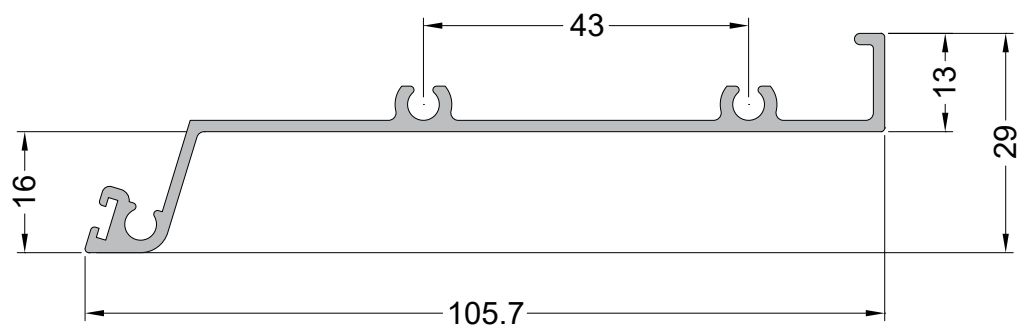

MN-010

1.495 Kg/m

Marco Inferior

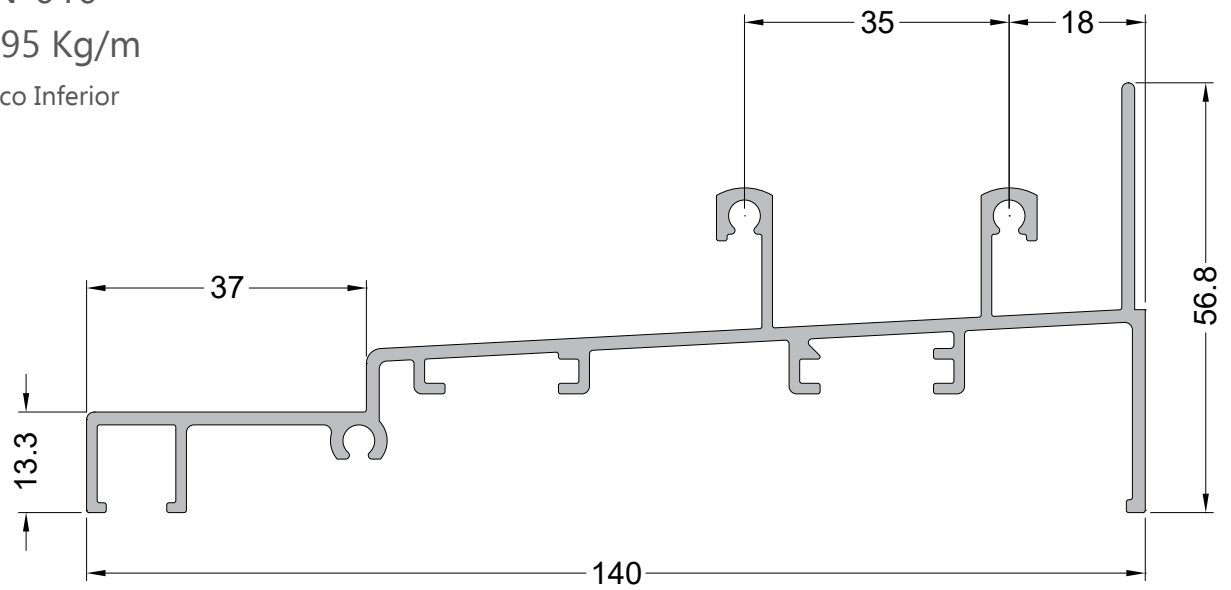

MN-003

1.091 Kg/m

Marco

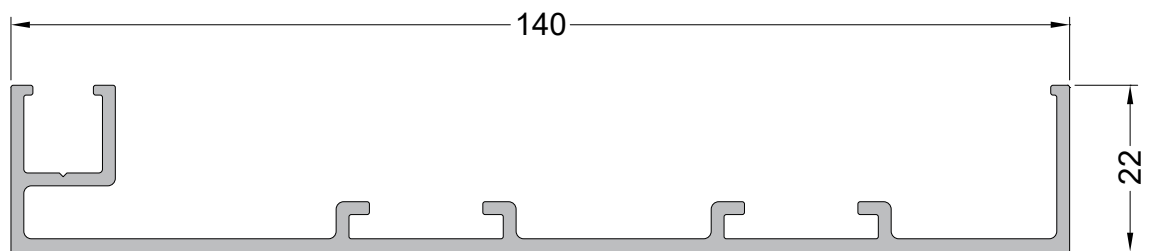



MN-050

0.738 Kg/m

Caixa do Recolhedor

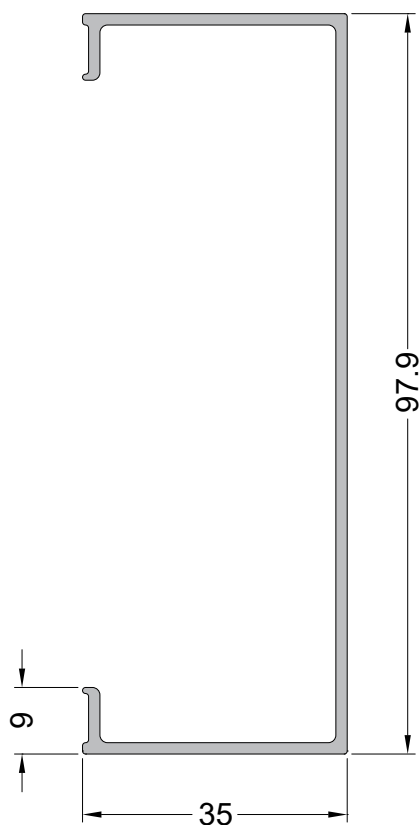

MN-055

0.376 Kg/m

Terminal

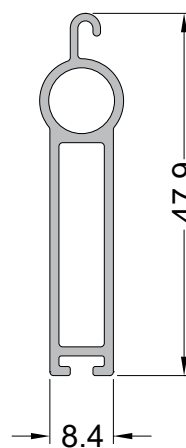

MN-007

0.710 Kg/m

Guia Persiana

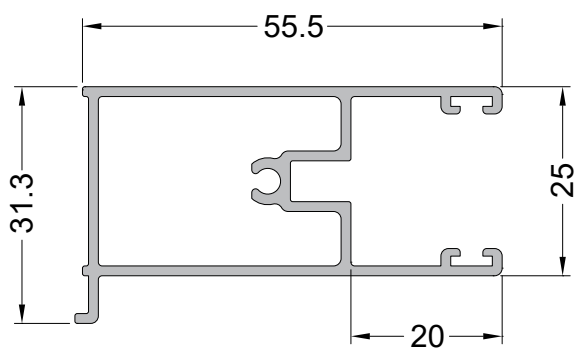

MN-004

0.176 Kg/m

Remate

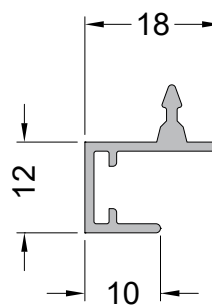

MN-031  
1.396 Kg/m  
Tampa Interna

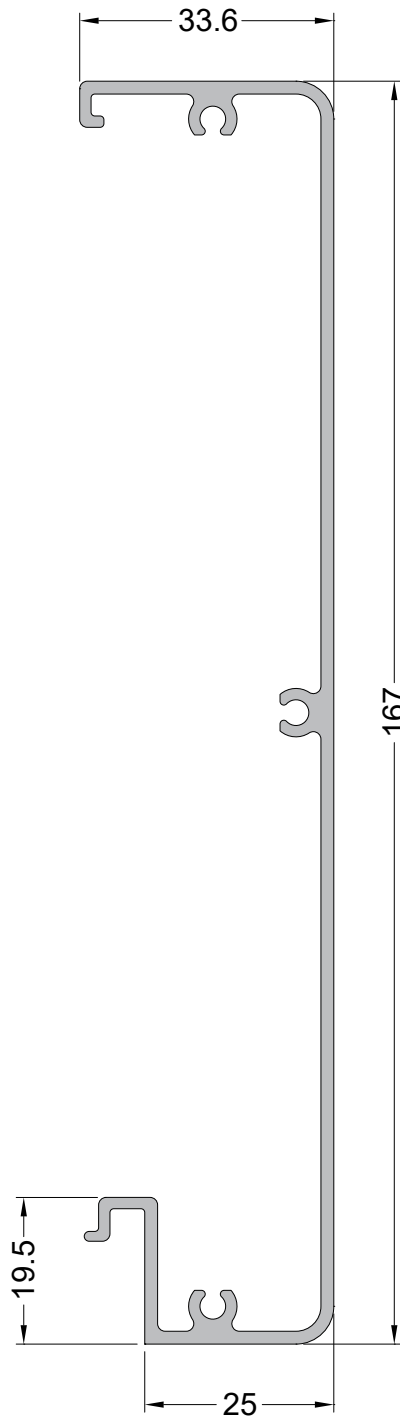

MN-039  
1.348 Kg/m  
Tampa Externa

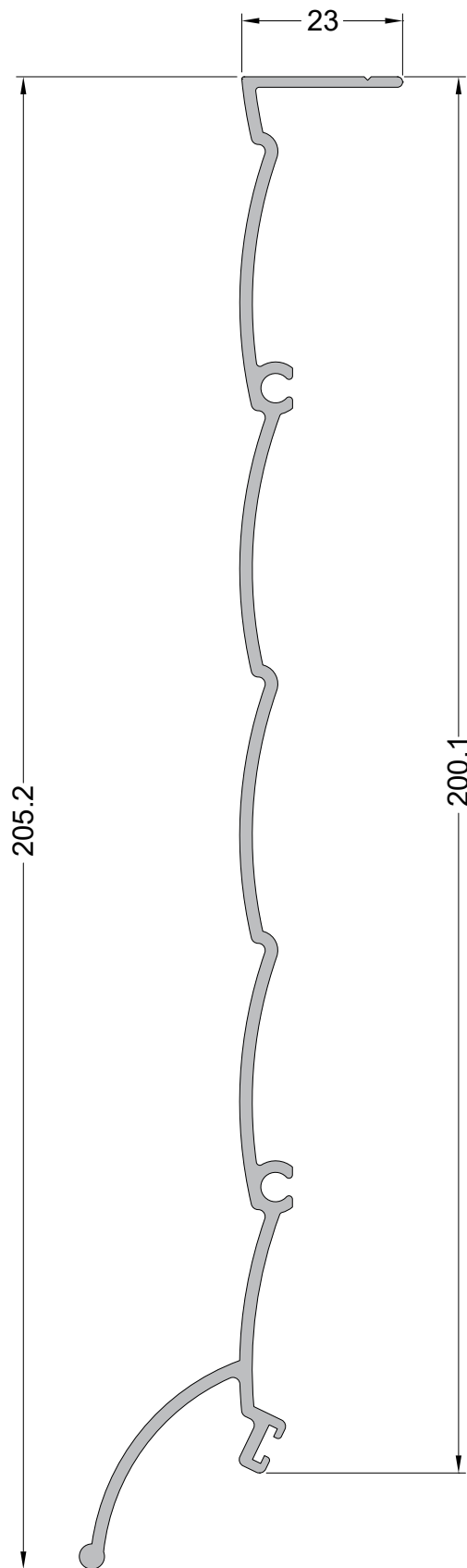

DS-238  
0.485 Kg/m  
Tubo Recolhedor

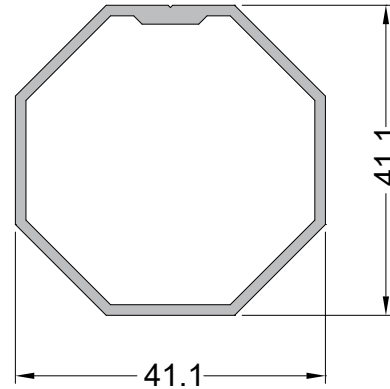

MN-015  
0.843 Kg/m  
Tubo Recolhedor

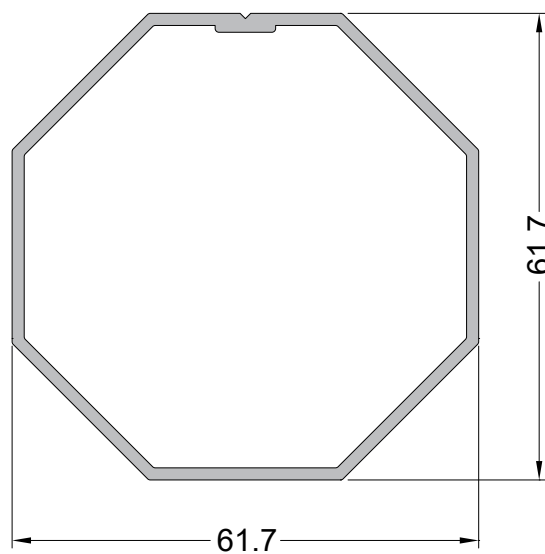

U-621 (FC-013)

0.281 Kg/m

Tampa

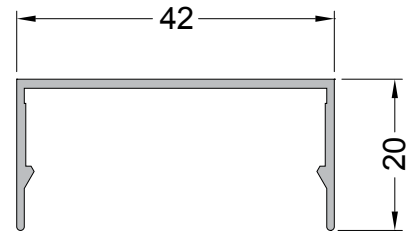

U-615 (FC-014)

0.362 Kg/m

Contra Tampa

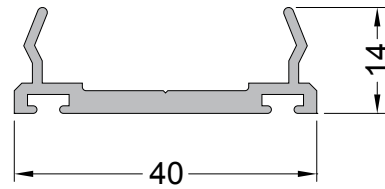

A-072 (FC-012)

1.269 Kg/m

Coluna

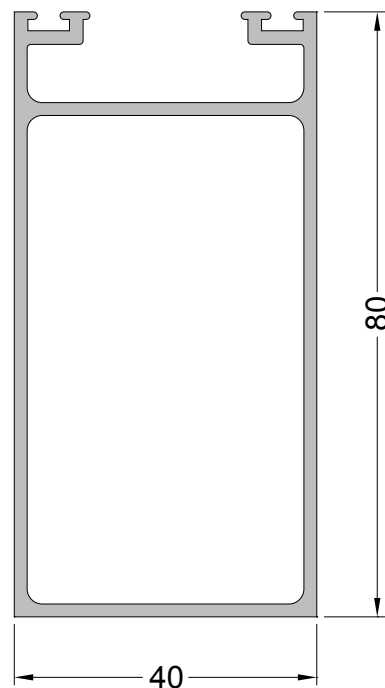

U-877 (FC-542)

0.339 Kg/m

Tampa

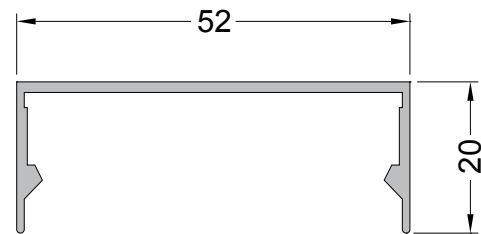

U-878 (FC-543)

0.371 Kg/m

Contra Tampa

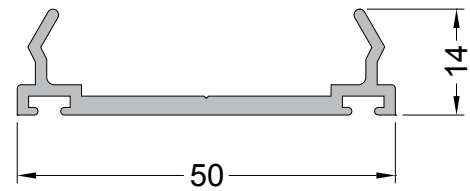

A-096 (FC-017)

1.860 Kg/m

Coluna

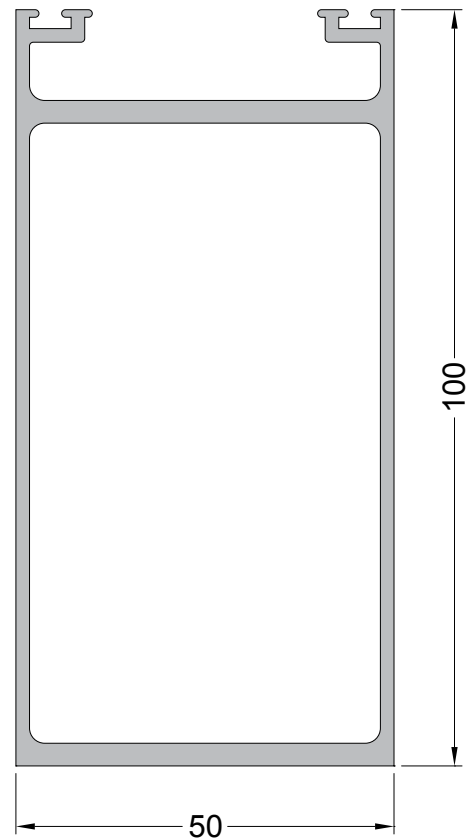

FC-544 (U-1312)

0.366 Kg/m

Tampa

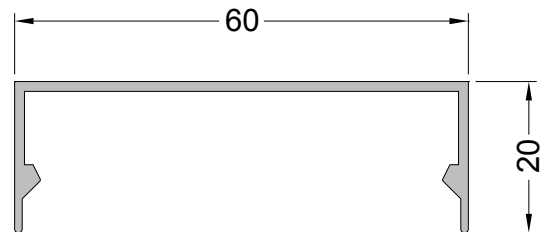

U-1086 (FC-419)

0.398 Kg/m

Contra Tampa

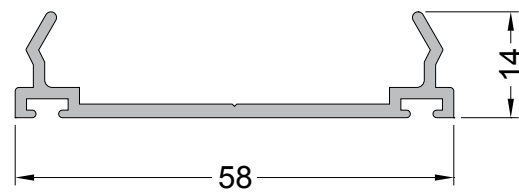

A-025 (FC-007)

2.062 Kg/m

Coluna

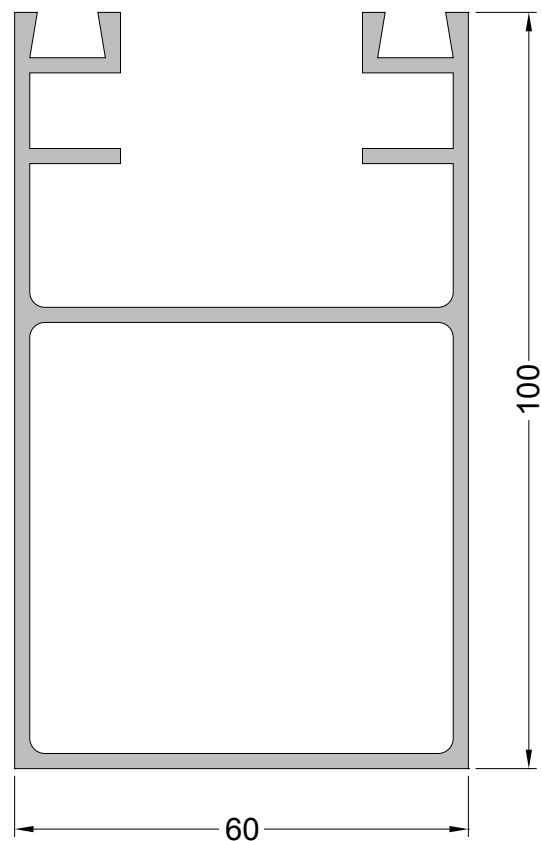

FC-124  
3.526 Kg/m  
Coluna

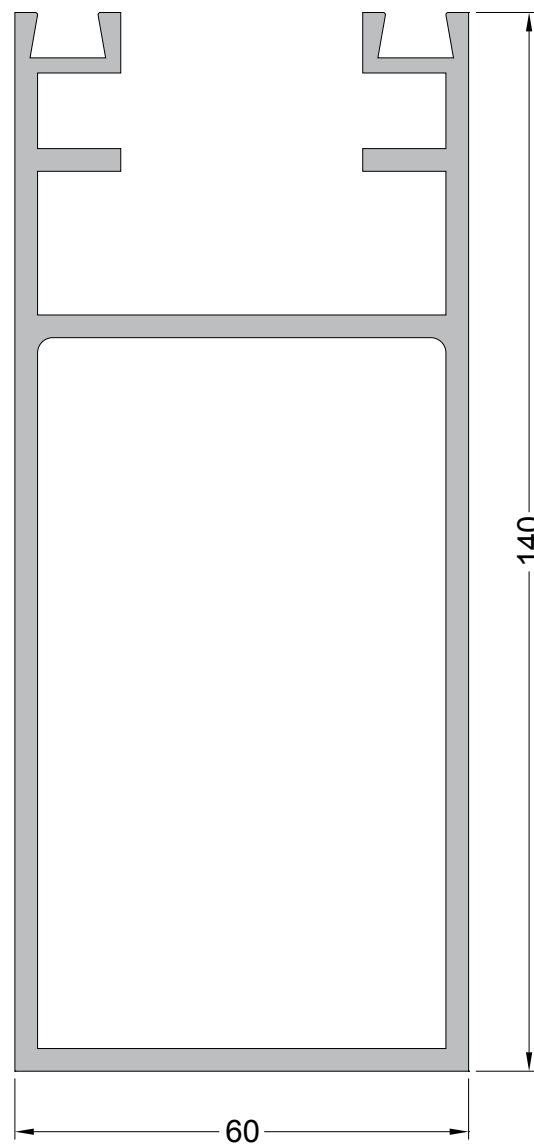



U-487

0.474 Kg/m

Tampa

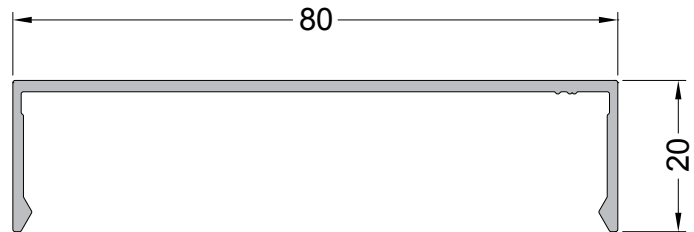

U-486

0.533 Kg/m

Contra Tampa

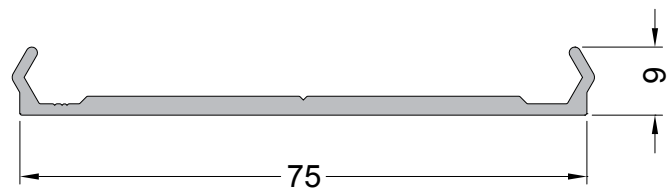

U-531

0.175 Kg/m

Tampa

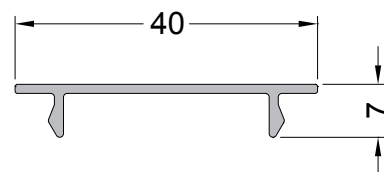

FC-265  
1.396 Kg/m  
Arremate

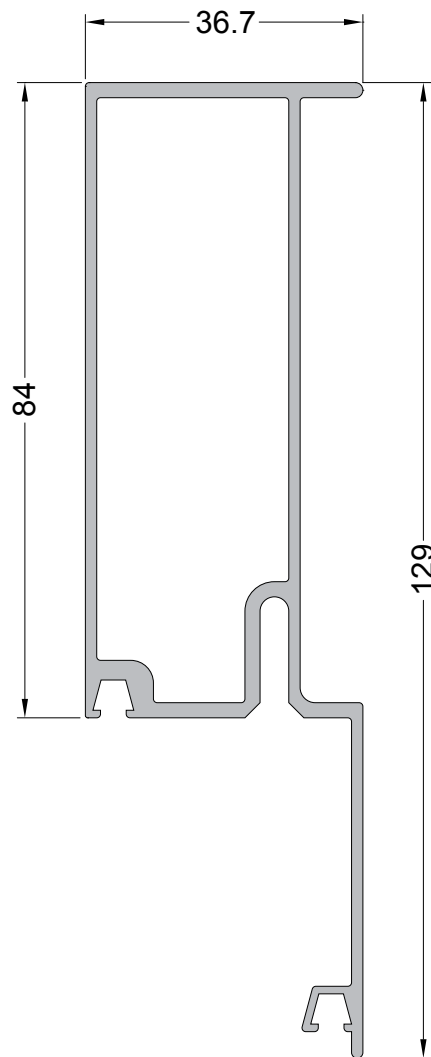

FC-202  
1.798 Kg/m  
Coluna

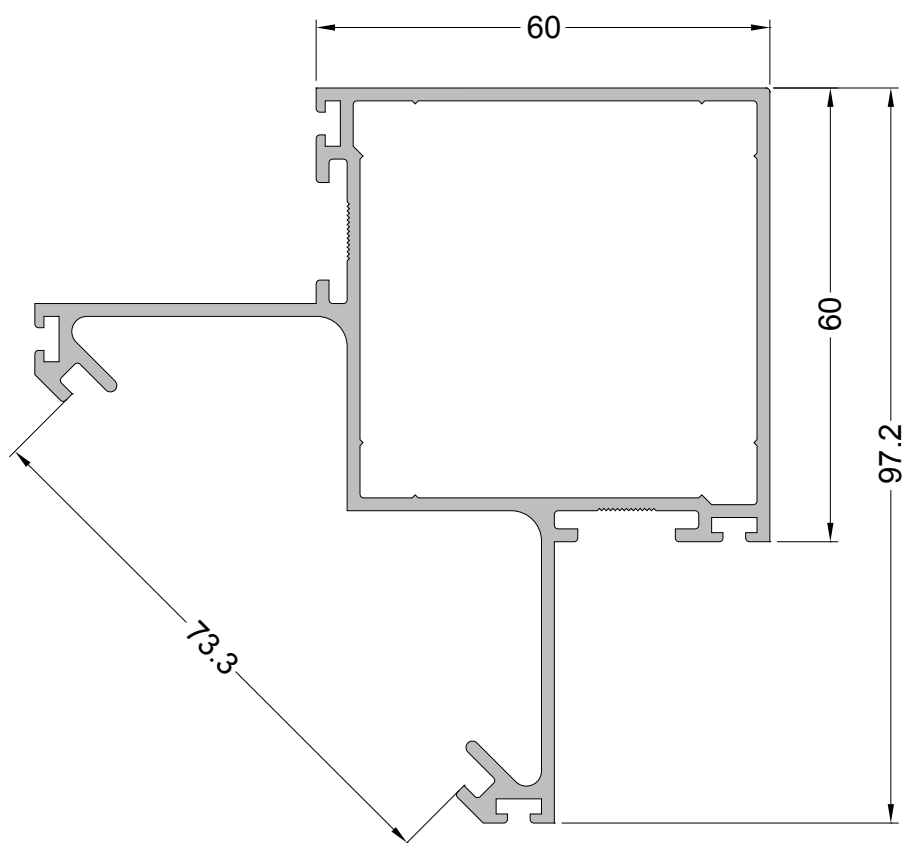
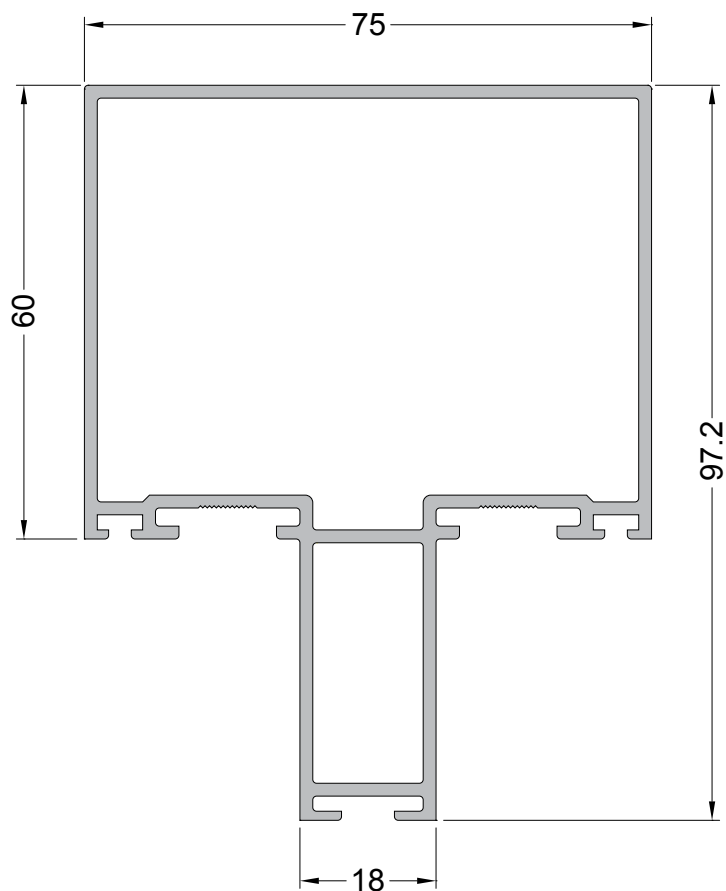

FC-244  
1.786 Kg/m  
Marco

FC-241  
1.807 Kg/m  
Coluna

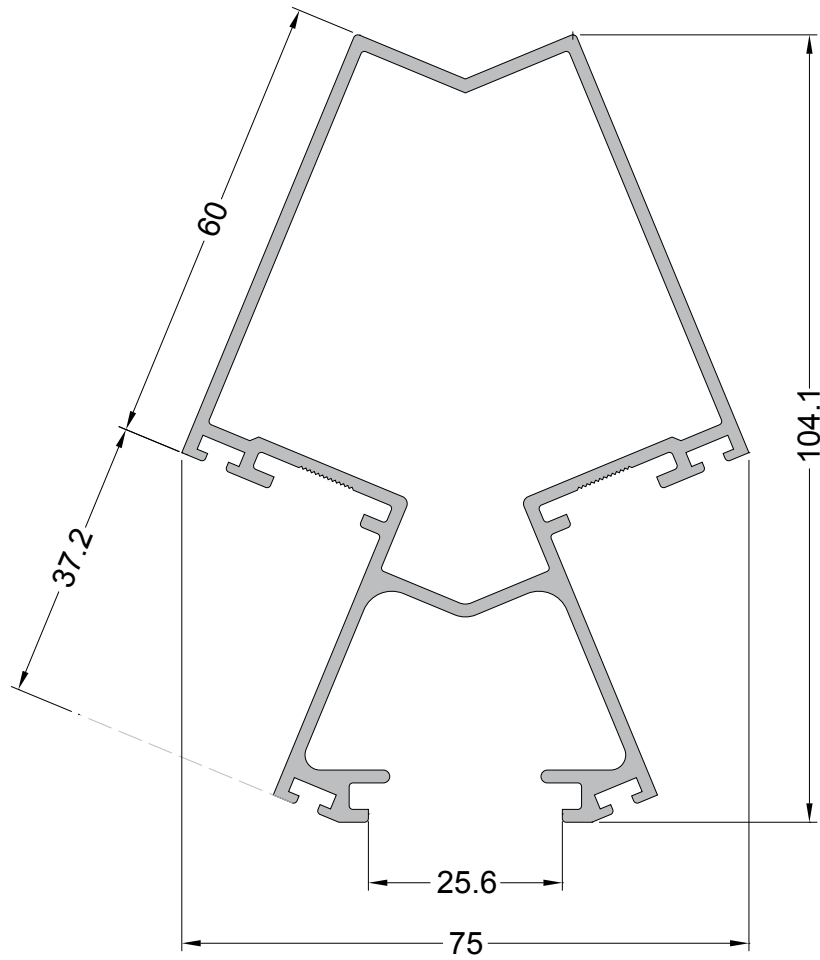

FC-232

1.320 Kg/m

Coluna

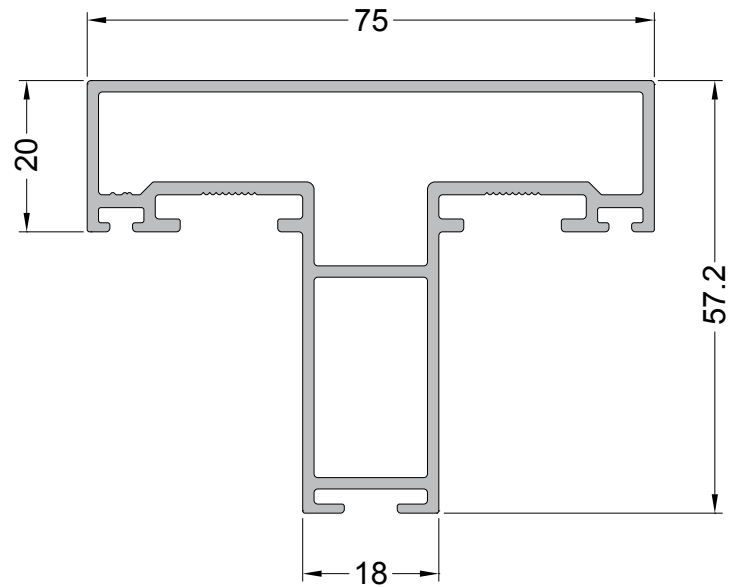

FC-231

1.077 Kg/m

Travessa

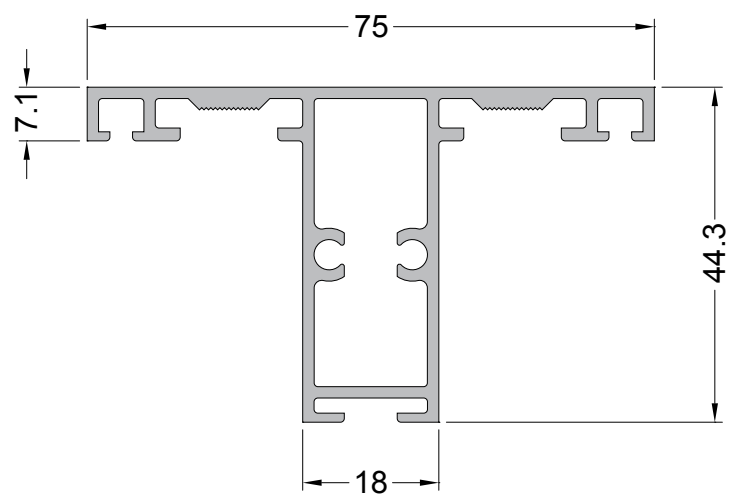

FC-243  
1.057 Kg/m  
Marco

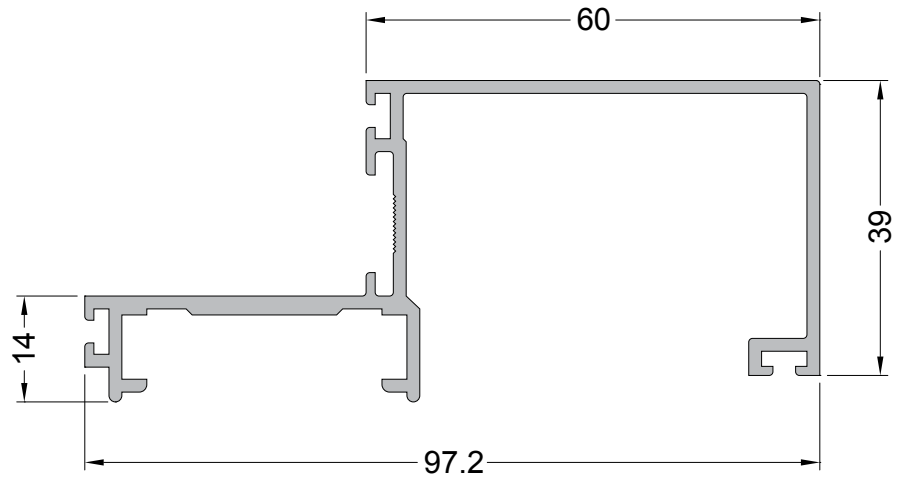

FC-225  
0.642 Kg/m  
Marco Max

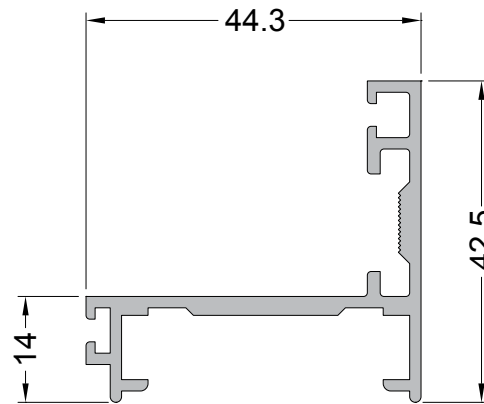

CX-329 (FC-687)  
0.462 Kg/m  
Pingadeira

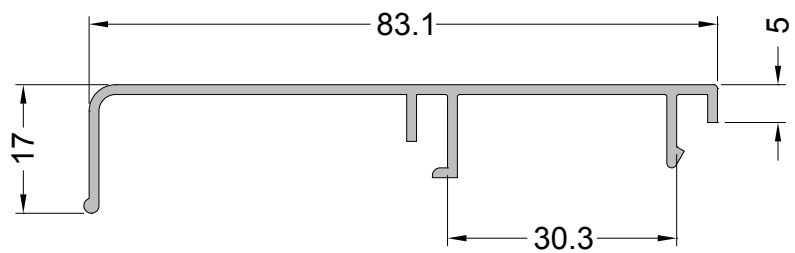

FC-254

0.621 Kg/m

Folha

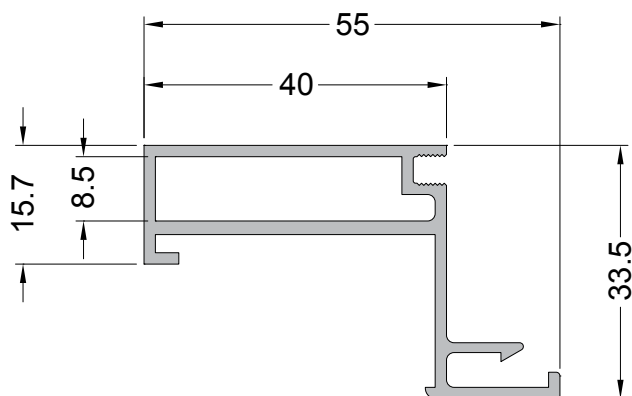

FC-293

0.645 Kg/m

Folha

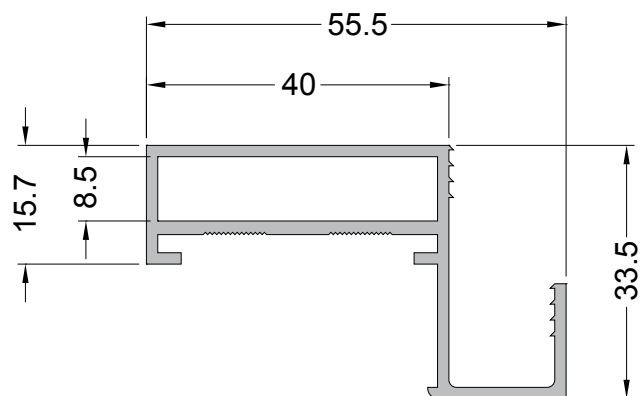

FC-228

0.565 Kg/m

Folha

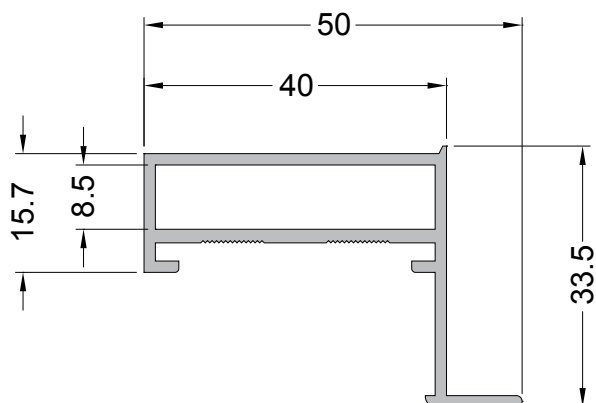

FC-261

0.555 Kg/m

Folha

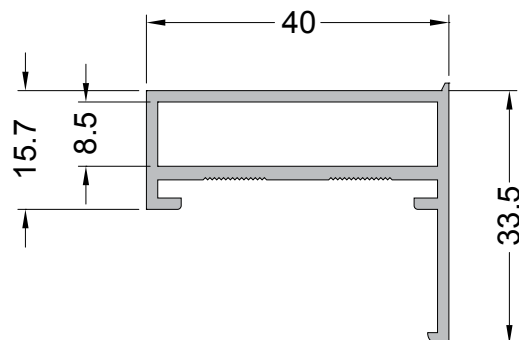

FC-227  
0.674 Kg/m  
Batedeira

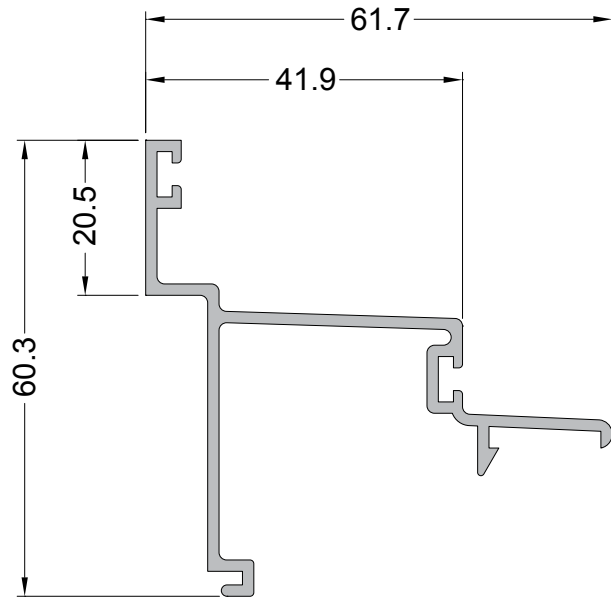

FC-249  
0.604 Kg/m  
Pingadeira

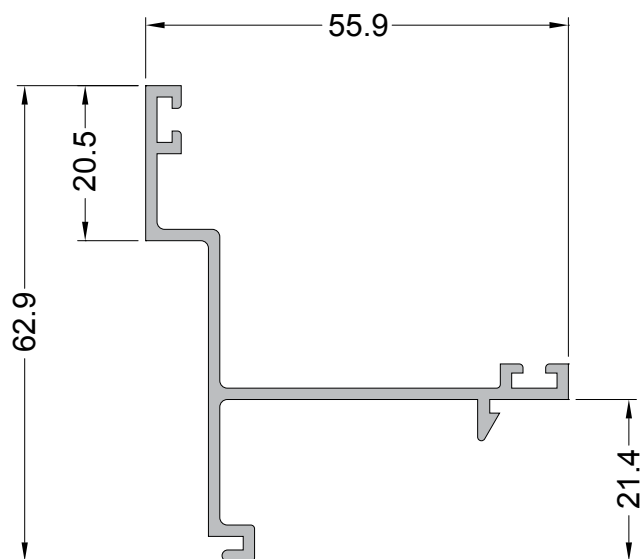



FC-222

0.789 Kg/m

Batedeira

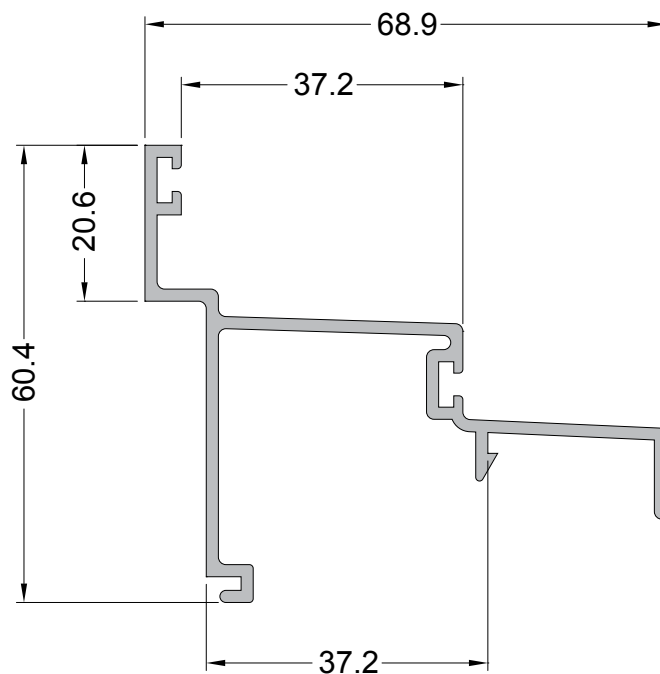

FC-226

0.748 Kg/m

Pingadeira

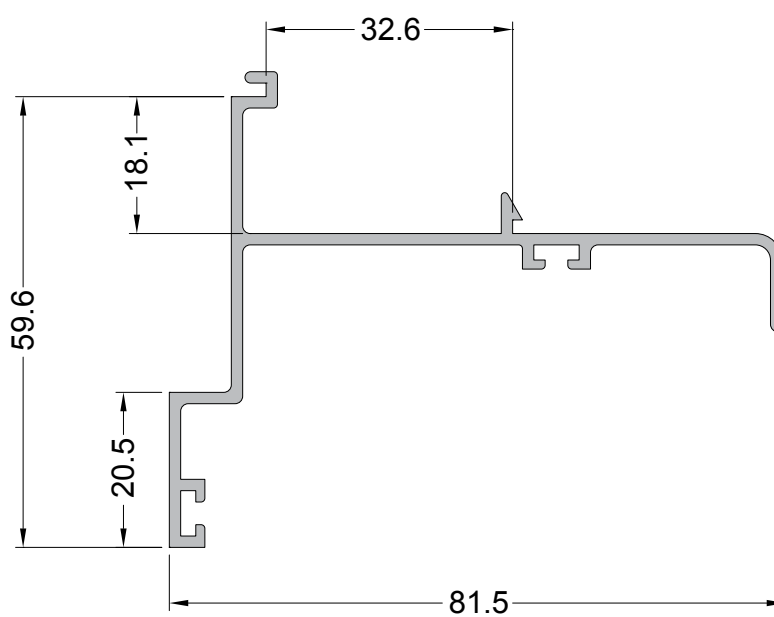

FC-245  
0.794 Kg/m  
Arremate

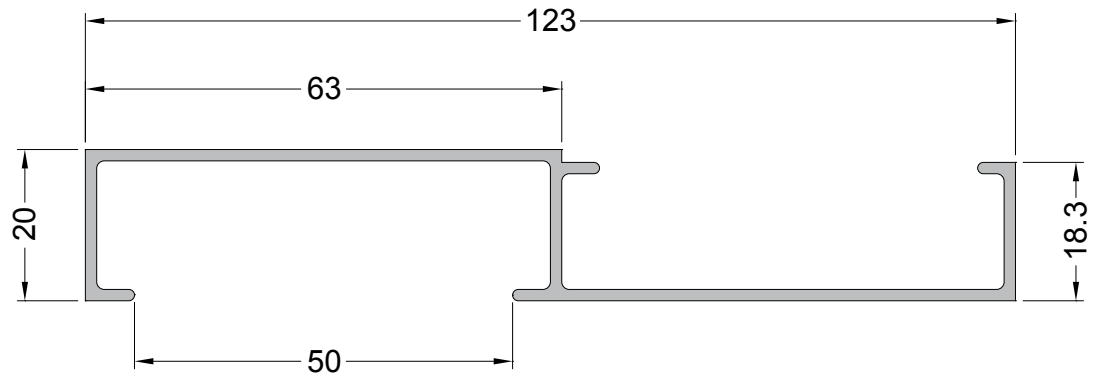

FC-250  
0.742 Kg/m  
Arremate

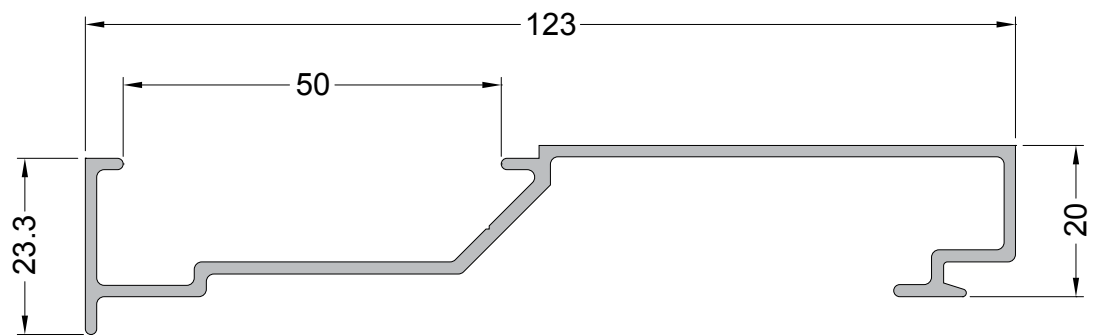

FC-256  
0.409 Kg/m  
Arremate

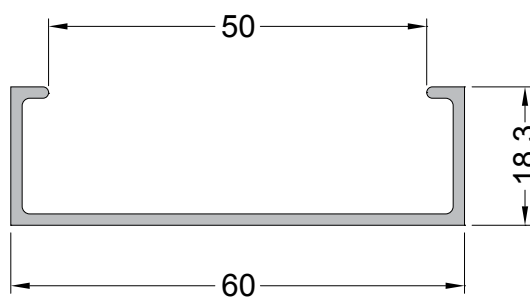

FC-085  
0.258 Kg/m  
Tampa

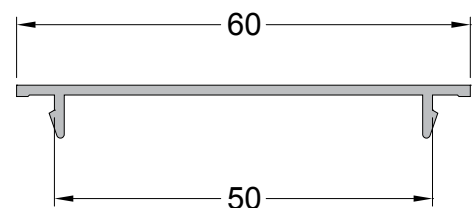

FC-258

0.485 Kg/m

Arremate

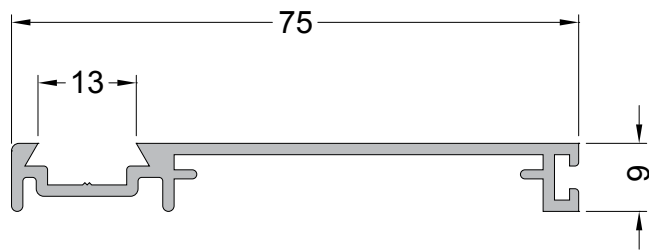

FC-247

0.414 Kg/m

Arremate

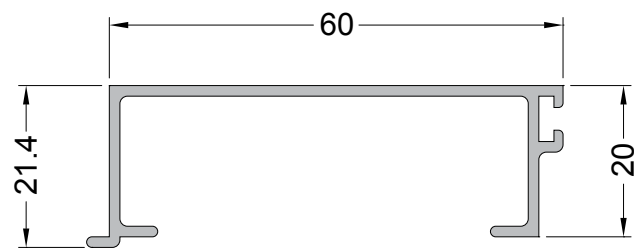

FC-246

0.767 Kg/m

Arremate

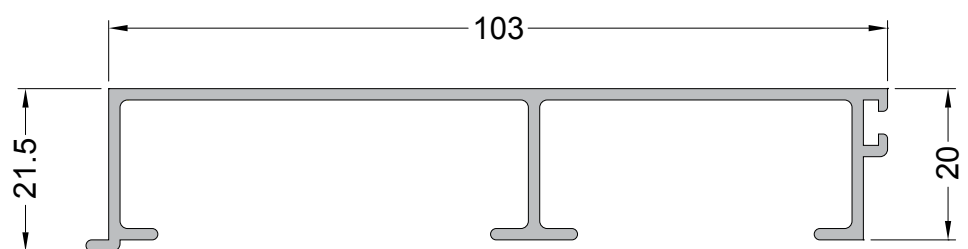

FC-087  
1.021 Kg/m  
Rufo

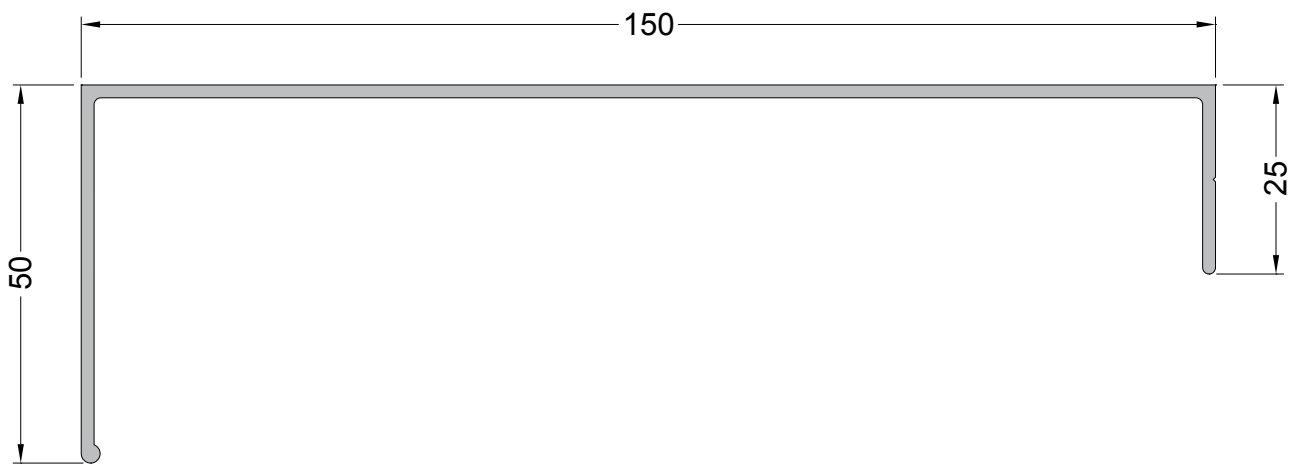

FC-088  
0.844 Kg/m  
Rufo

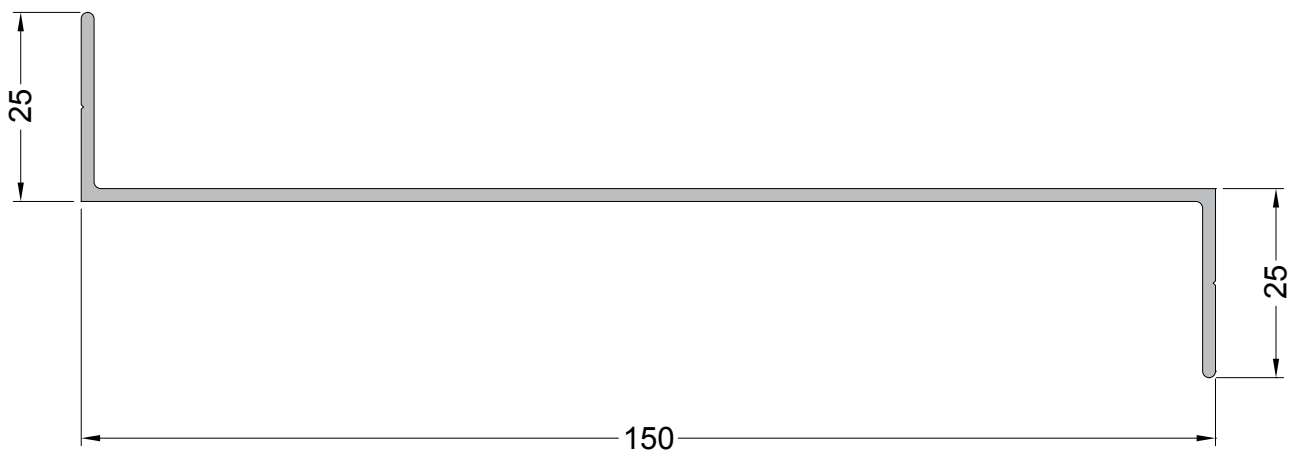

CG-143

1.948 Kg/m

Corrimão

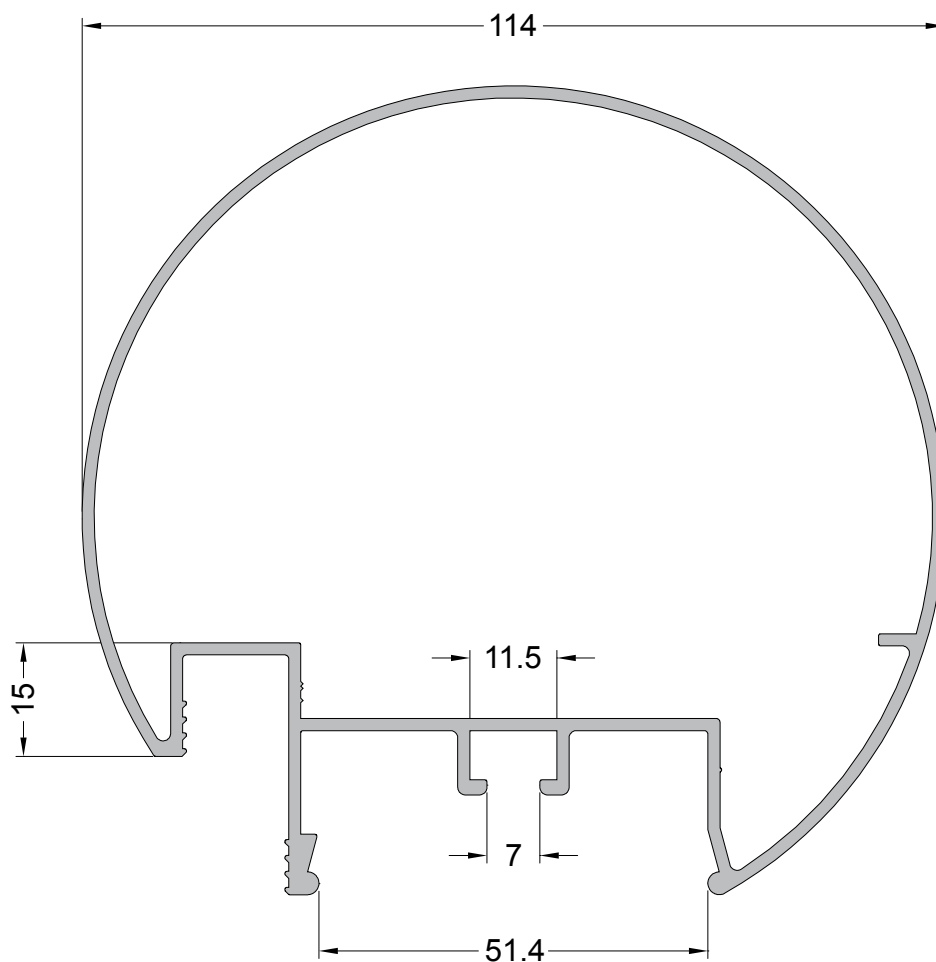

CG-083

1.403 Kg/m

Corrimão

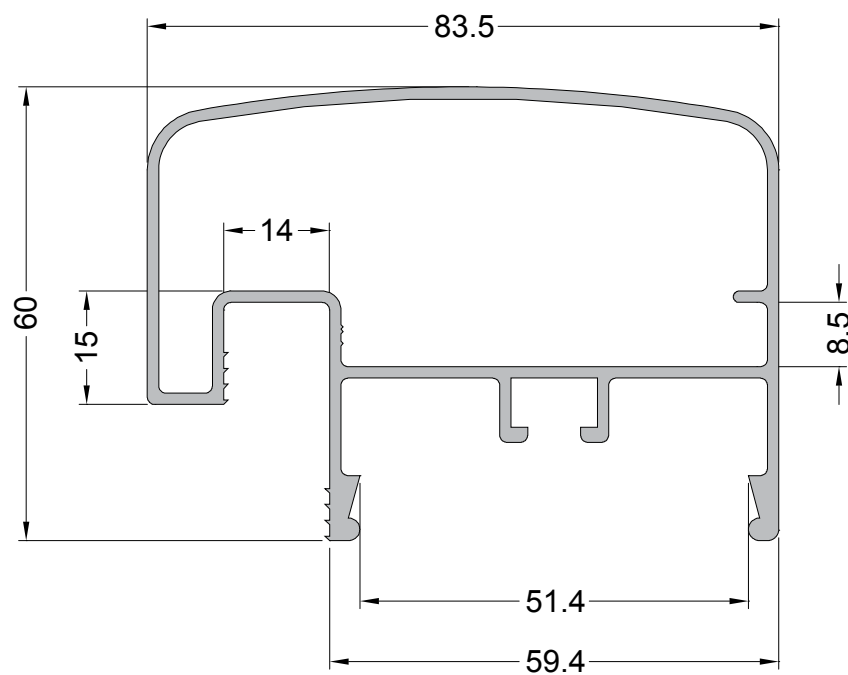

D-201  
1.891 Kg/m  
Corrimão

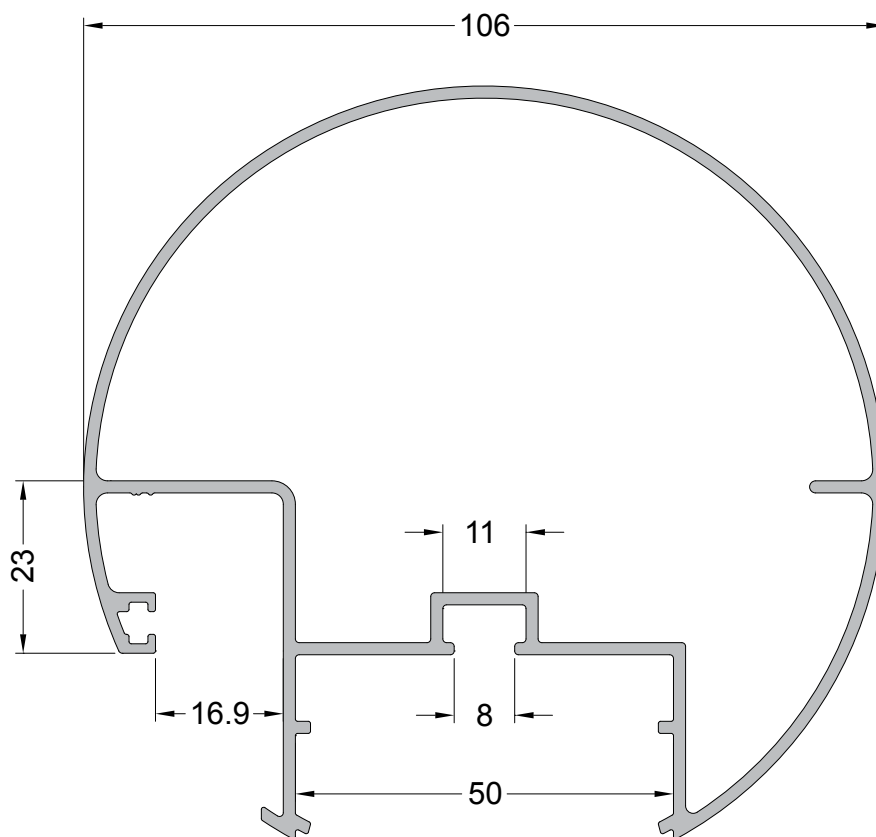

D-143 (CG-072)  
1.216 Kg/m  
Corrimão

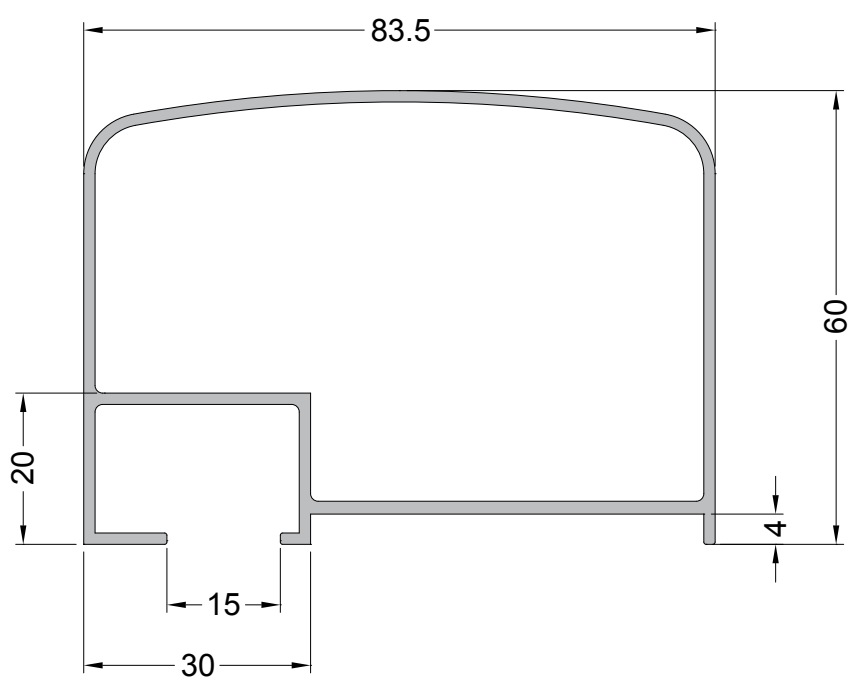

CX-3106 (CG-145)

0.670 Kg/m

Corrimão

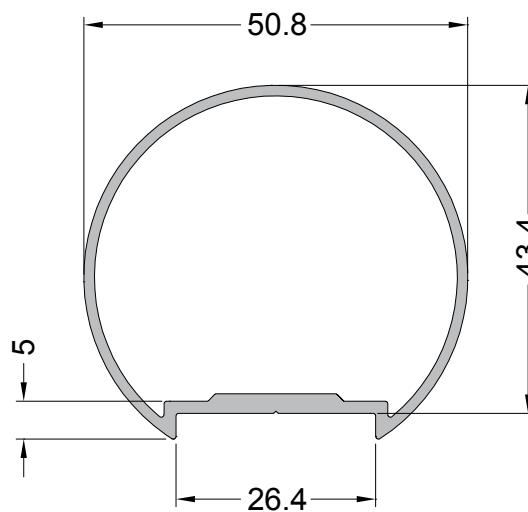

D-095 (CG-003)

0.436 Kg/m

Corrimão

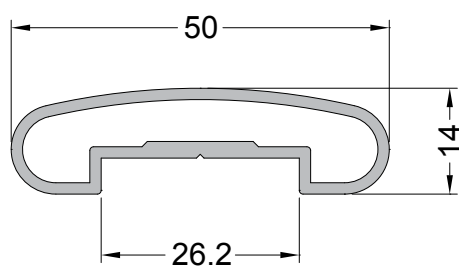

CG-078

0.493 Kg/m

Corrimão

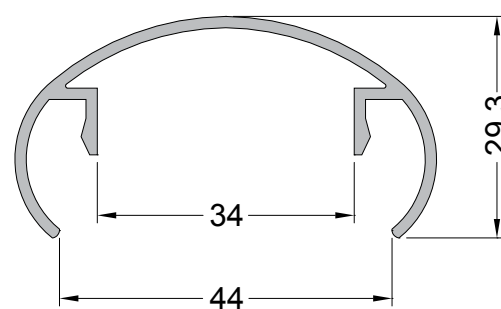

CG-074  
0.266 Kg/m  
Tampa

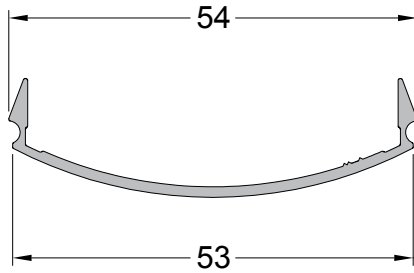

CG-079  
0.330 Kg/m  
Corrimão

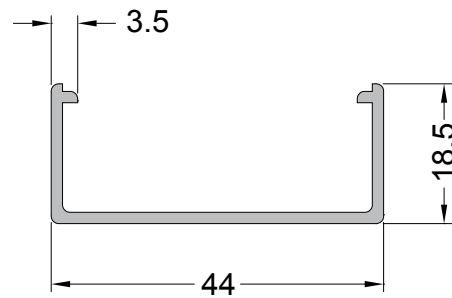

CX-3284  
1.248 Kg/m  
Travessa

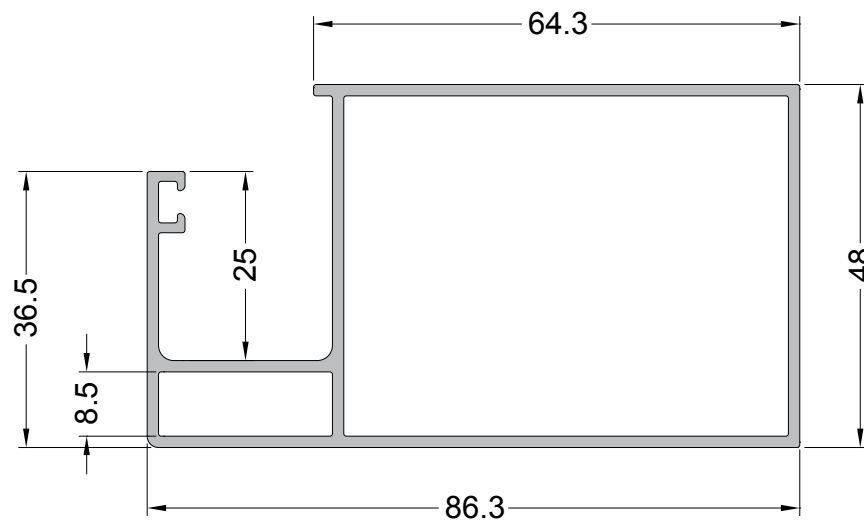

CX-3069  
0.547 Kg/m  
Apoio Vidro

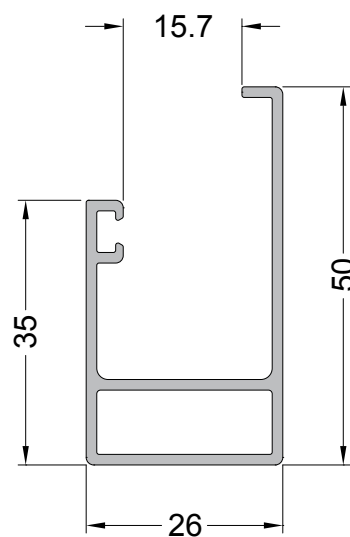



L-809 (CG-101)

0.510 Kg/m

Calha

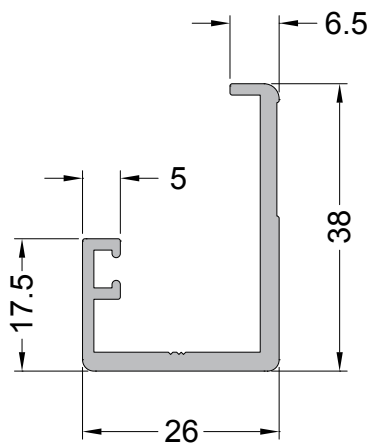

CG-075

0.520 Kg/m

Calha

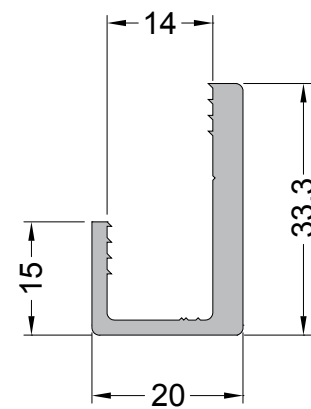

U-495 (CG-019)

0.169 Kg/m

Tampa

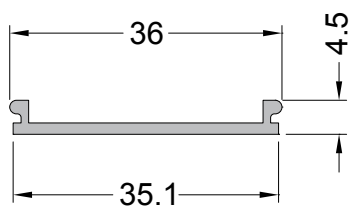

U-496 (CG-017)

0.363 Kg/m

Travessa

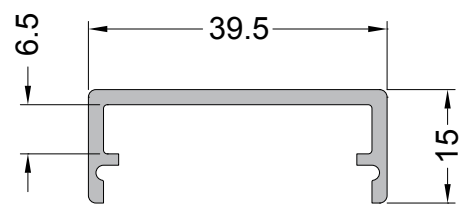

D-198  
0.870 Kg/m  
Pontaleta

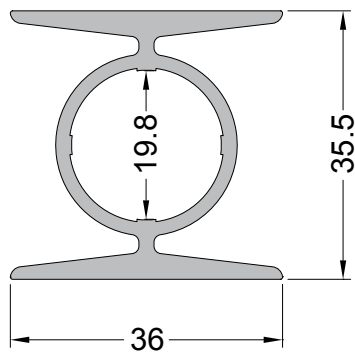

D-199  
0.820 Kg/m  
Montante

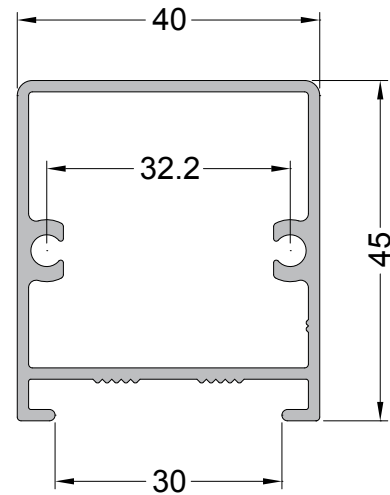

CG-077  
0.843 Kg/m  
Montante

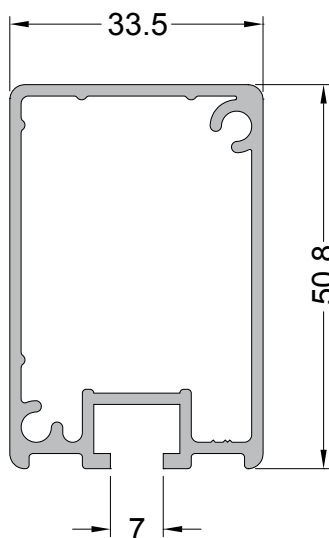

D-082 (CG-021)

0.321 Kg/m

Tubo

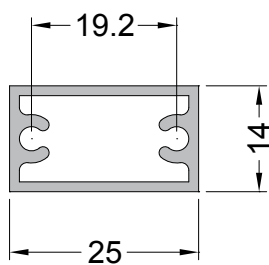

D-056 (CG-024)

0.322 Kg/m

Tubo

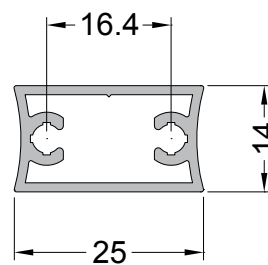

D-070 (CG-022)

0.247 Kg/m

Tubo

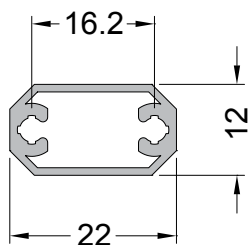

D-185

0.374 Kg/m

Tubo

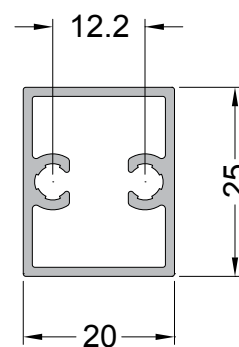

D-055 (CG-012)

0.504 Kg/m

Tubo

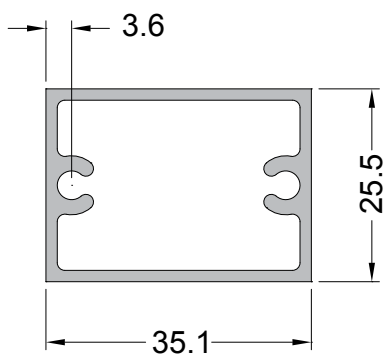

D-081 (CG-243)

0.571 Kg/m

Tubo

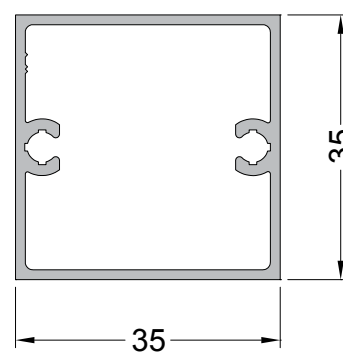

D-103 (CG-104)

0.780 Kg/m

Tubo

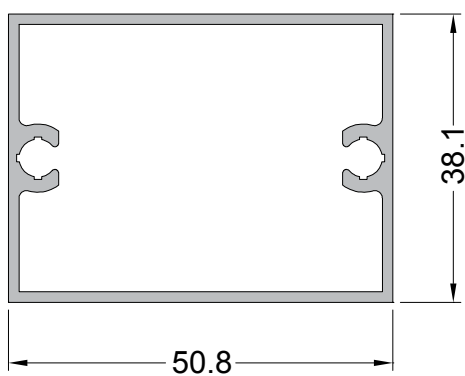

CX-3288

0.640 Kg/m

Arremate

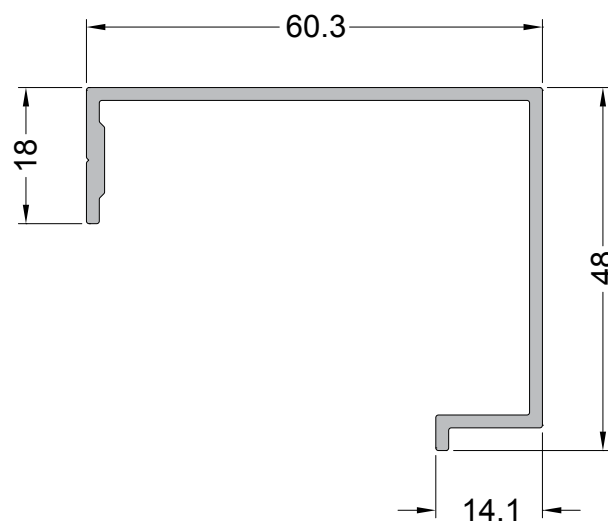

CX-306 (PC-027)

0.786 Kg/m

Folha

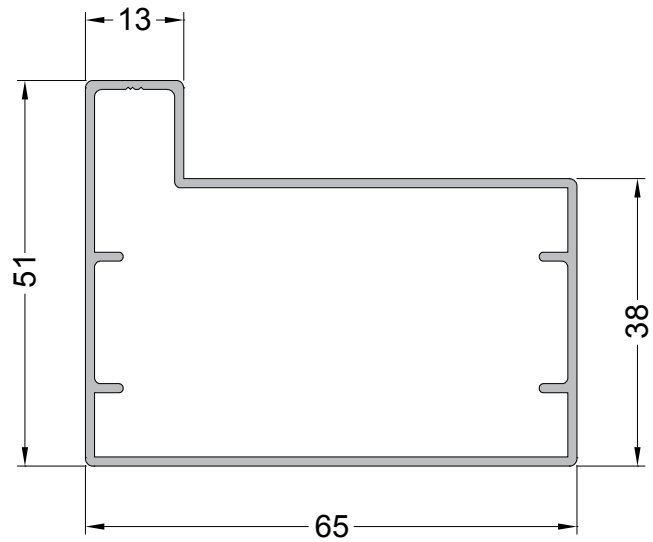

PC-010

0.987 Kg/m

Folha

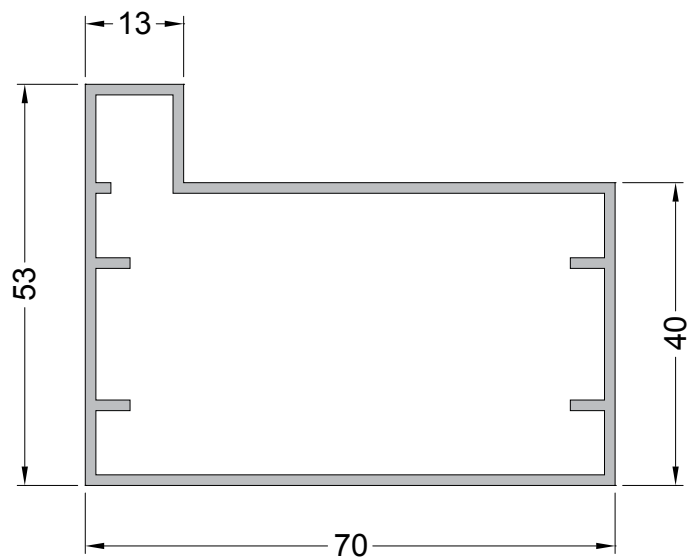

D-079 (PC-002)

0.604 Kg/m

Folha

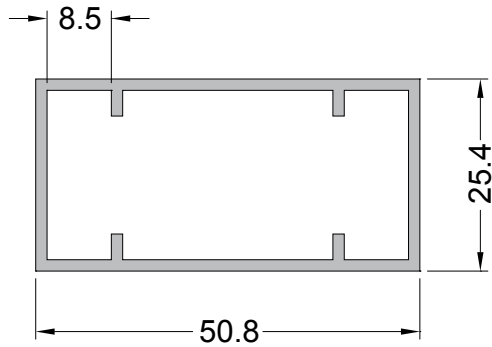

D-102 (PC-102)

0.587 Kg/m

Folha

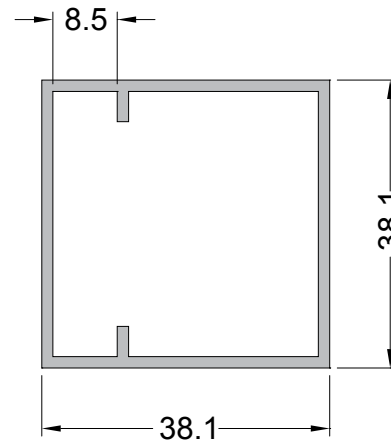

D-078 (PC-004)

0.748 Kg/m

Folha

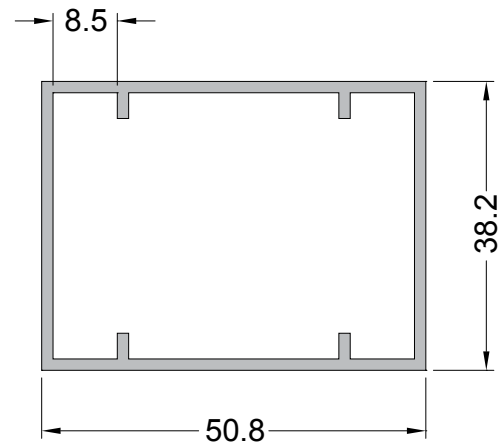

D-069 (PC-003)

1.043 Kg/m

Folha

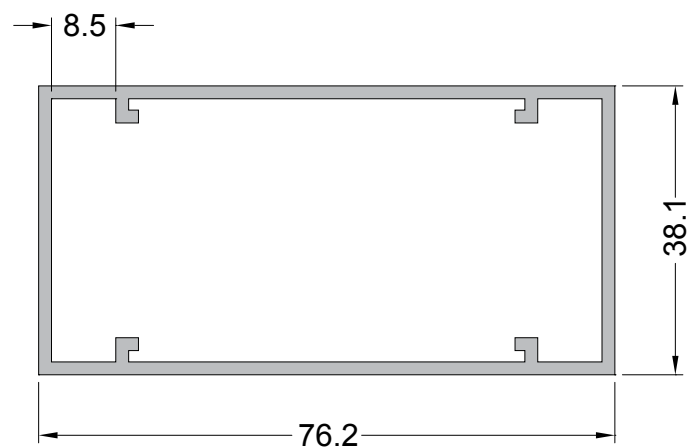

E-363 (PC-001)

1.046 Kg/m

Trilho superior

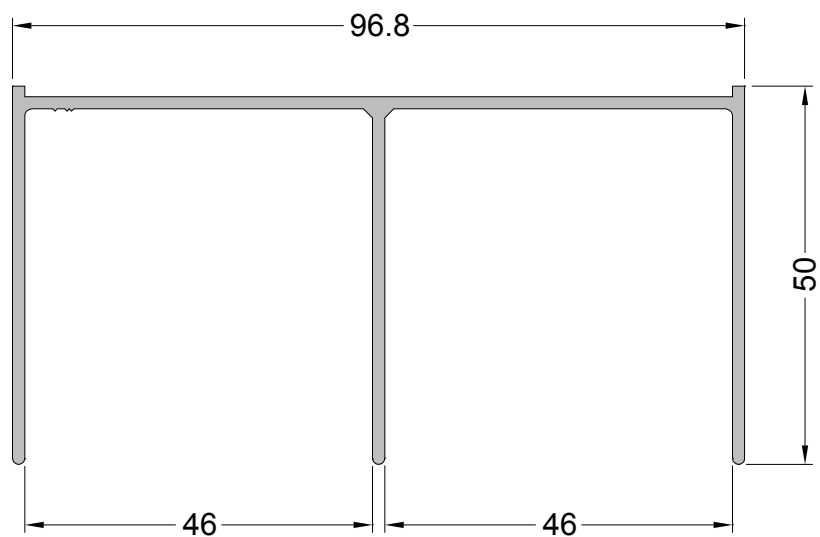

U-1098 (DS-266)

0.550 Kg/m

Trilho Superior

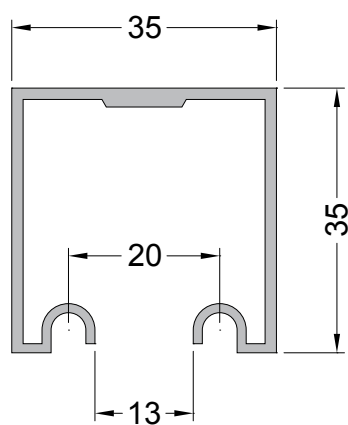

DS-314

0.639 Kg/m

Trilho Superior

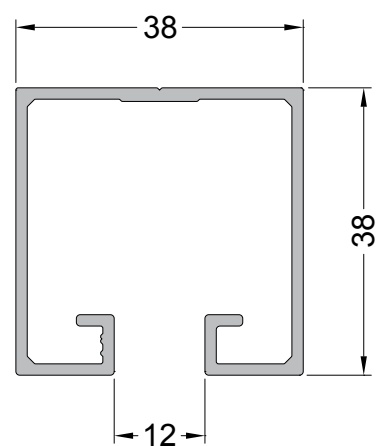

CX-3086  
1.458 KG/M  
Trilho Superior

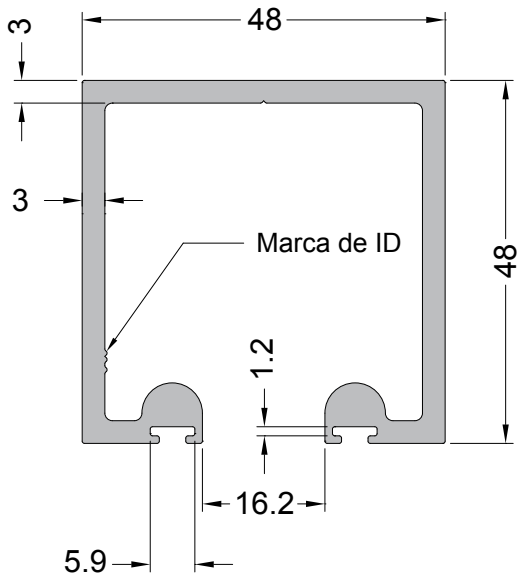

E-364 (PC-006)  
0.426 Kg/m  
Trilho Inferior Individual

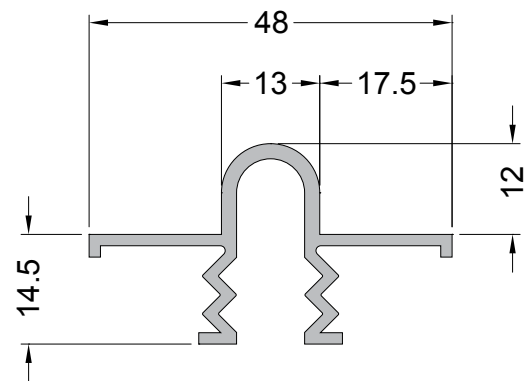

E-365 (PC-005)  
0.669 Kg/m  
Trilho Inferior

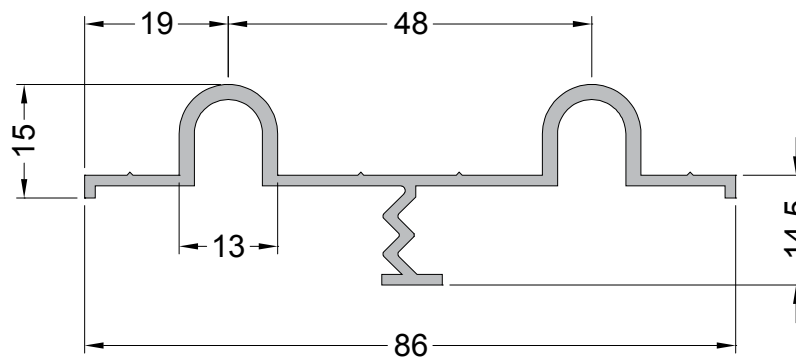



A-101 (30-044)

0.223 Kg/m

Trilho

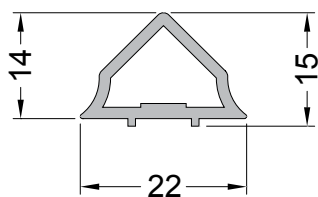

A-213 (30-245)

0.263 Kg/m

Trilho

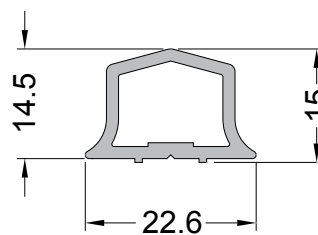

Z-063 (CR-159)

0.295 Kg/m

Baguete

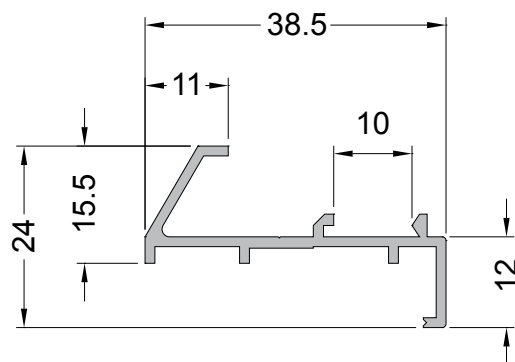

Z-201S (VZ-058)

0.262 Kg/m

Veneziana

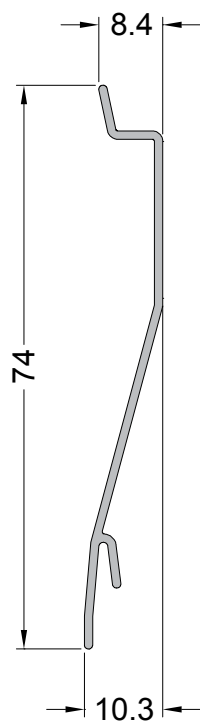

Z-163 (VZ-004)

0.258 Kg/m

Veneziana

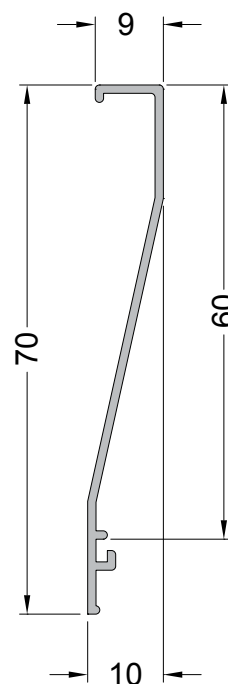

Z-524 (VZ-024)

0.268 Kg/m

Veneziana

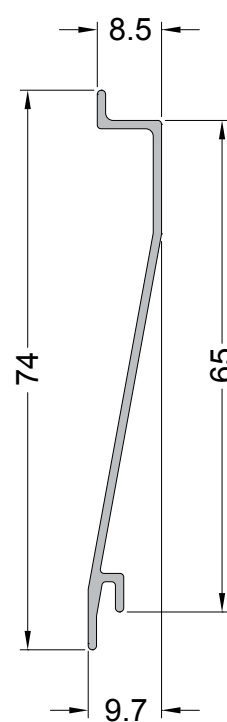

Z-284 (VZ-051)

0.269 Kg/m

Veneziana

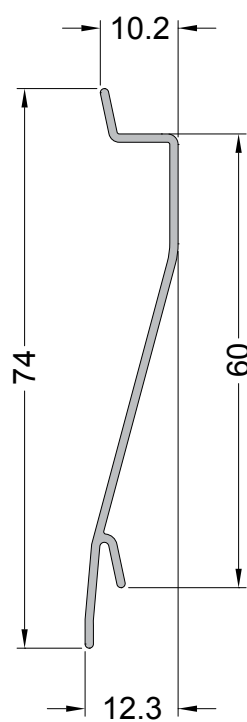

VZ-023  
0.293 Kg/m  
Veneziana

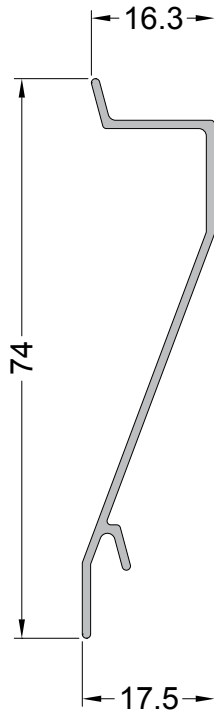

Z-148 (VZ-001)  
0.295 Kg/m  
Veneziana

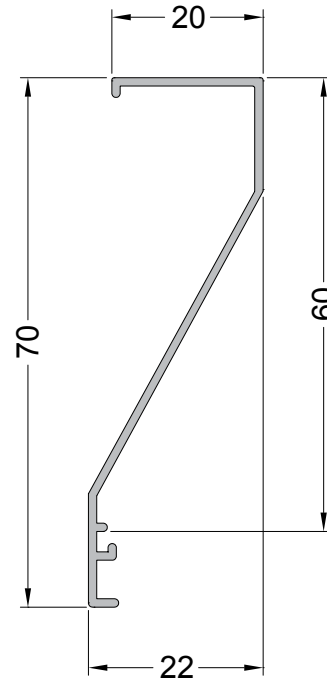

Z-203 (VZ-006)  
0.304 Kg/m  
Veneziana

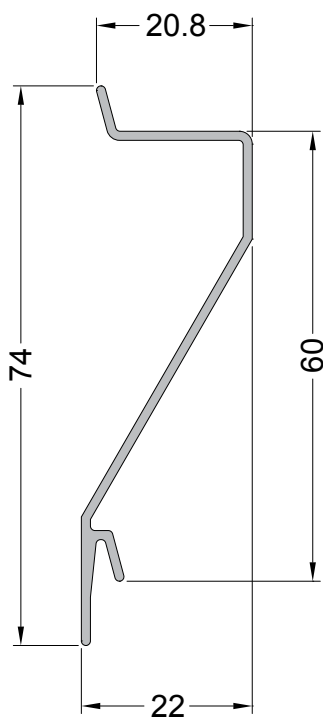

Z-990  
0.260 Kg/m  
Veneziana

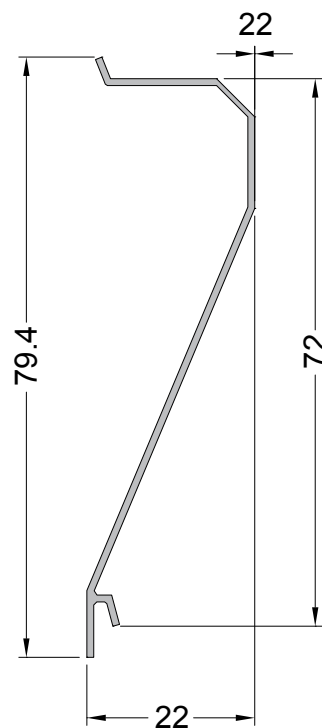

Z-145 (VZ-177)

0.286 Kg/m

Veneziana

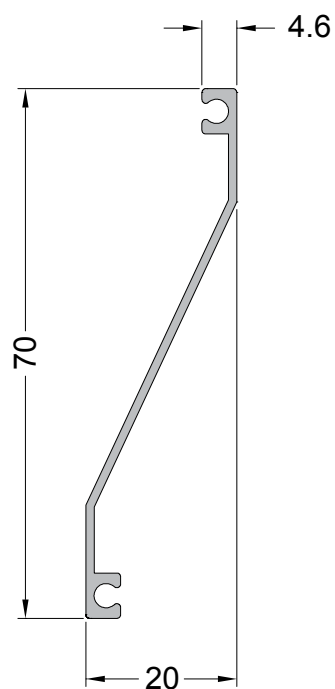

Z-194 (VZ-005)

0.352 Kg/m

Veneziana

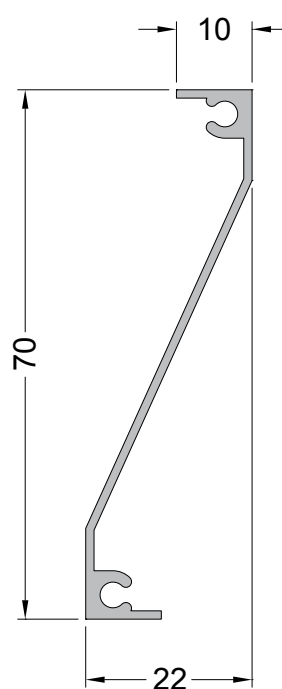

VZ-064

0.516 Kg/m

Veneziana

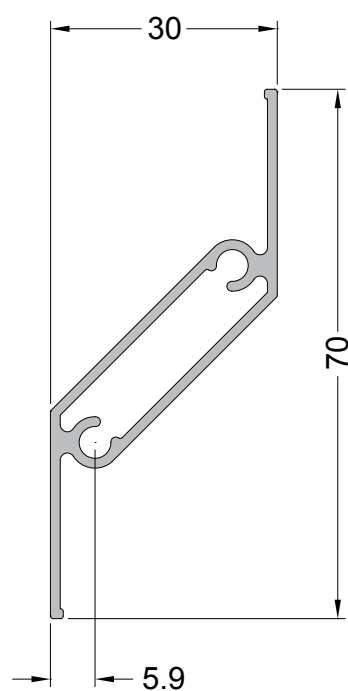

CX-3276

0.434 Kg/m

Veneziana

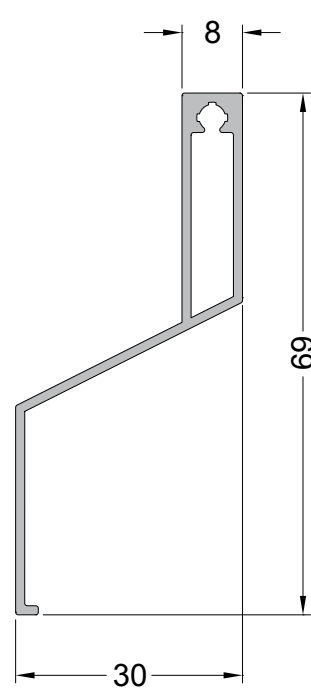

VZ-060

0.377 Kg/m

Veneziana

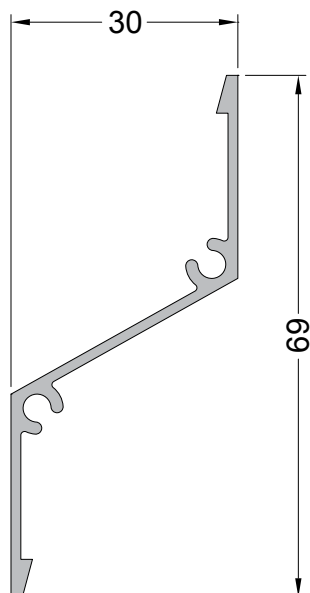

CX-3275

0.184 Kg/m

Veneziana

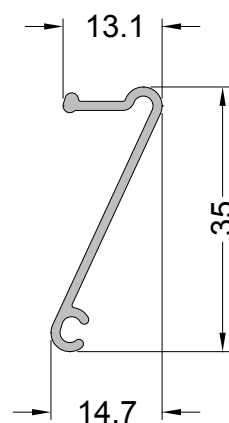

Y-689 (VZ-049)

0.300 Kg/m

Veneziana

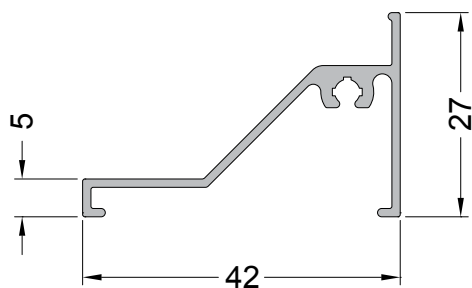

Z-248 (VZ-047)

0.271 Kg/m

Veneziana

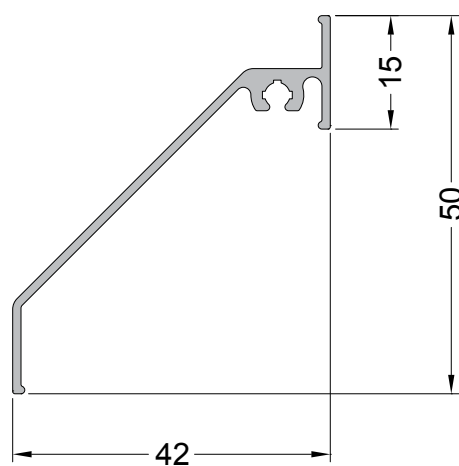

BR-75902  
0.264 Kg/m  
Veneziana

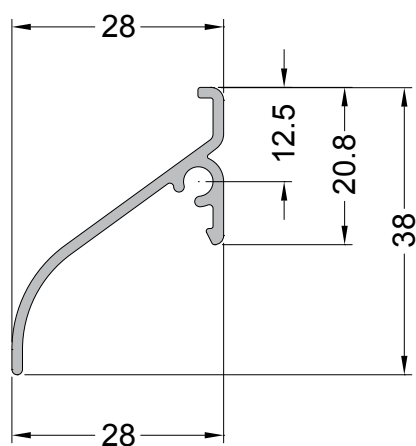

CX-3073  
0.148 Kg/m  
Veneziana

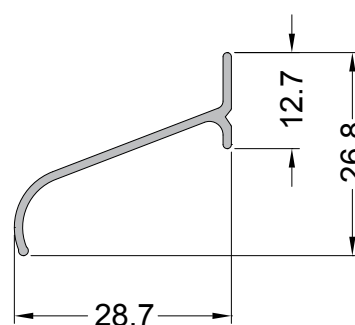

VZ-037  
0.154 Kg/m  
Veneziana

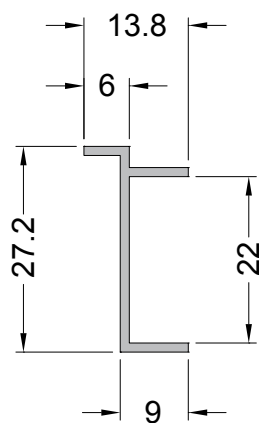

BR-75901  
0.272 Kg/m  
Veneziana

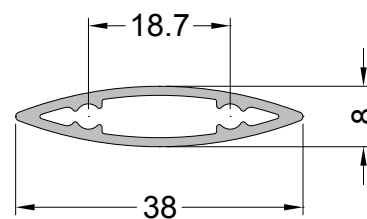

CX-3220  
0.757 Kg/m  
Veneziana

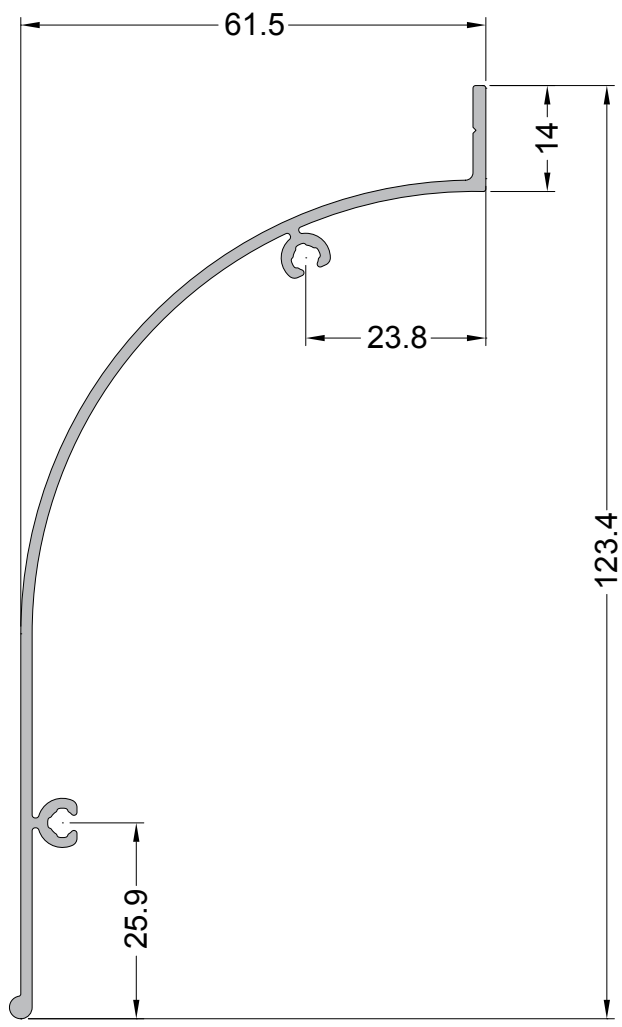

Y-335 (LB-036)

0.789 Kg/m

Lambri

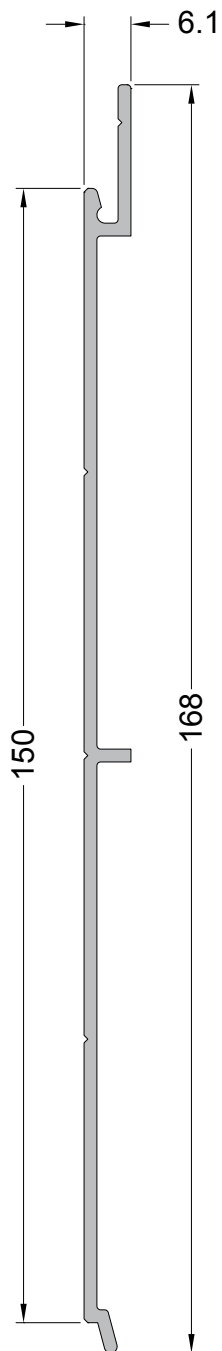

Y-355

0.708 Kg/m

Lambri

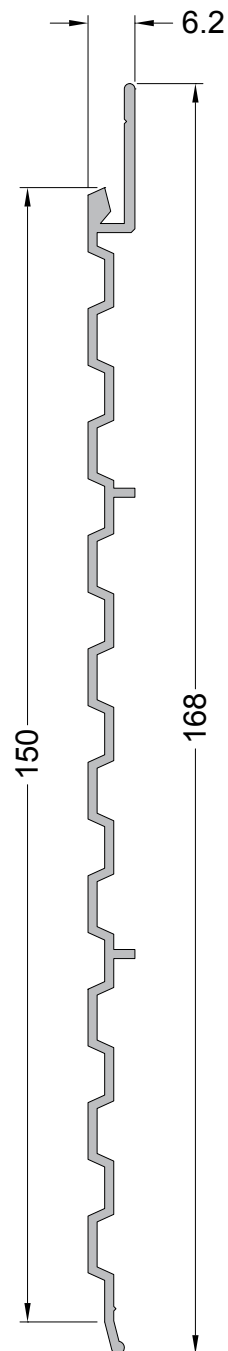

Y-429 (LB-050)

0.624 Kg/m

Lambri

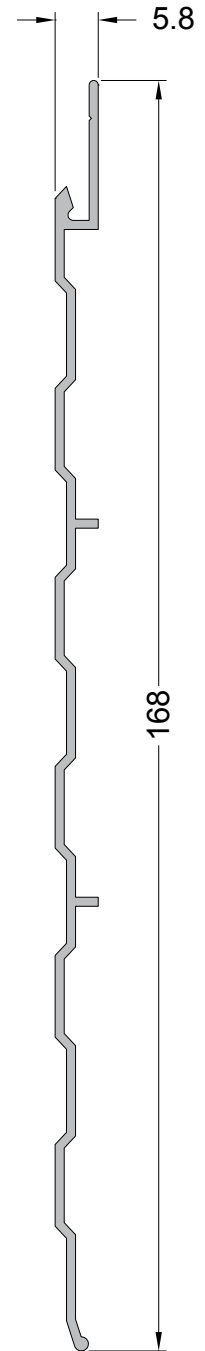



# LAMBRIS

CX-307

0.762 Kg/m

Lambri



LB-038

0.996 Kg/m

Lambri

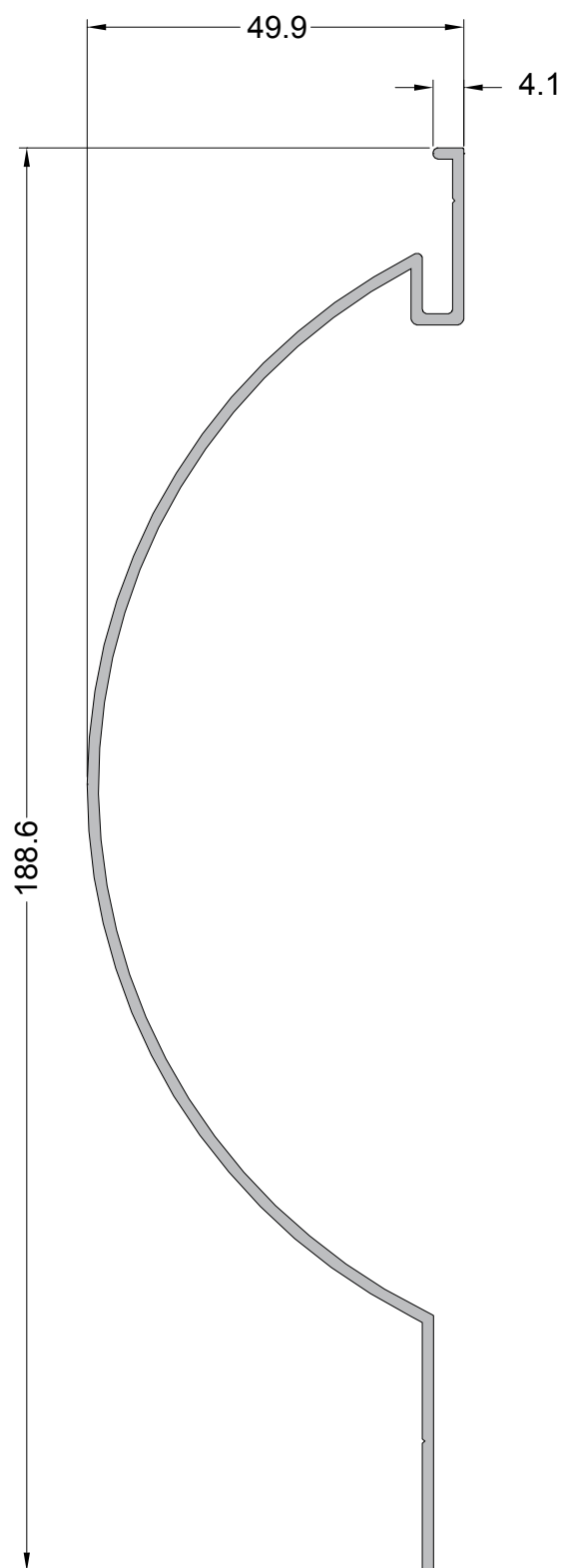

CX-3258  
1.536 Kg/m  
Lambri

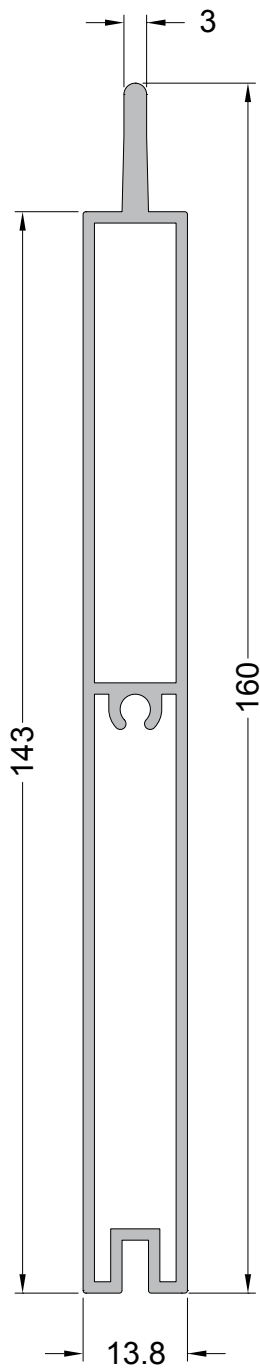

CX-3244  
1.551 Kg/m  
Lambri

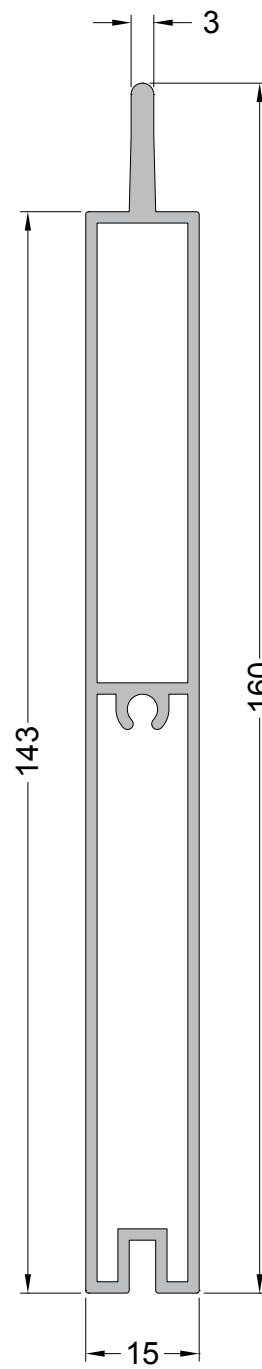

CX-3245

1.697 Kg/m

Lambri

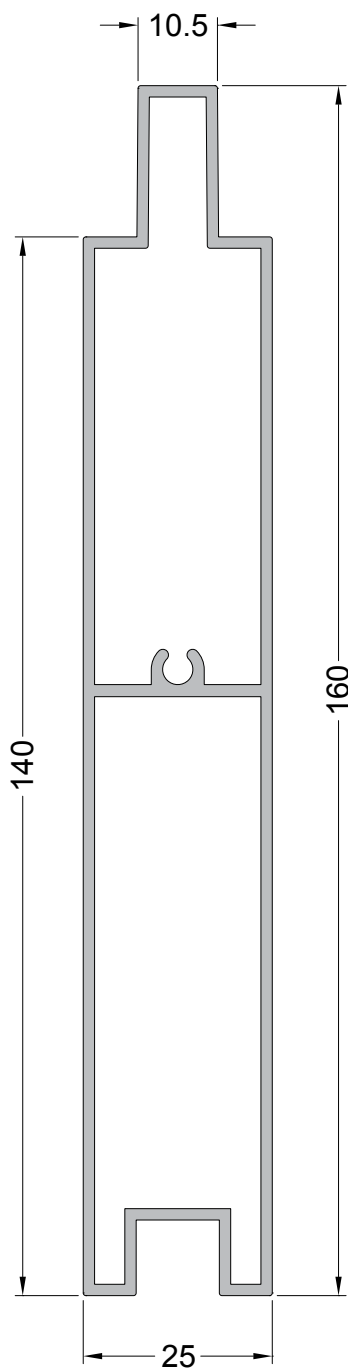

A-082 (DC-008)

1.505 Kg/m

Brise

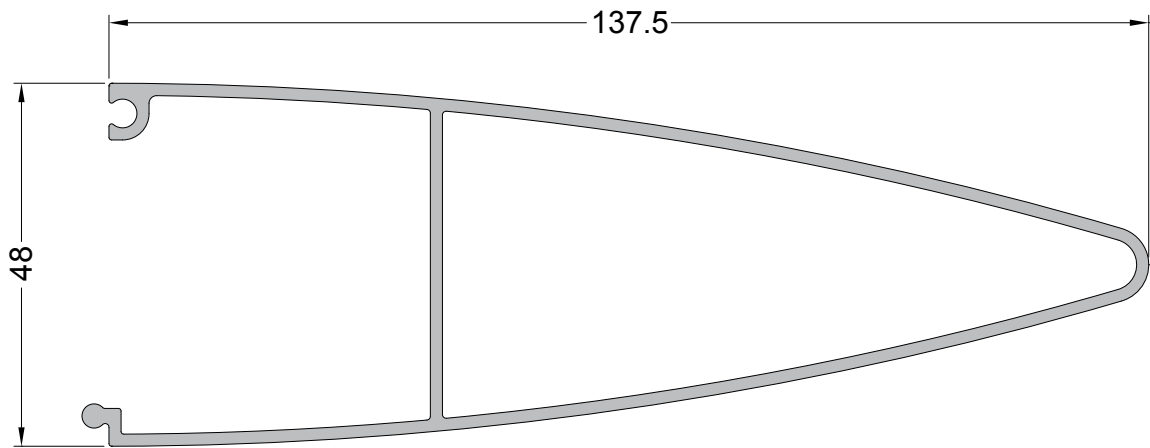

D-072 (DC-032)

1.318 Kg/m

Brise

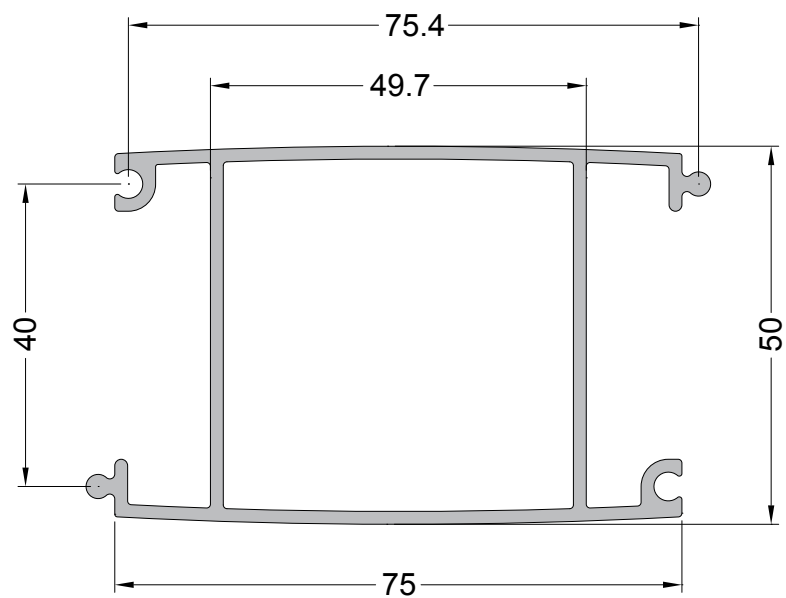

# BRISES

D-059

0.813 Kg/m

Brise

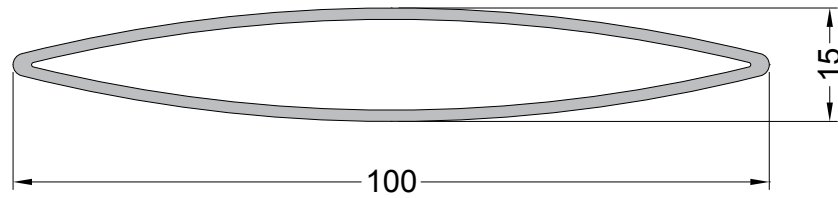

D-053 (DC-004)

1.233 Kg/m

Brise

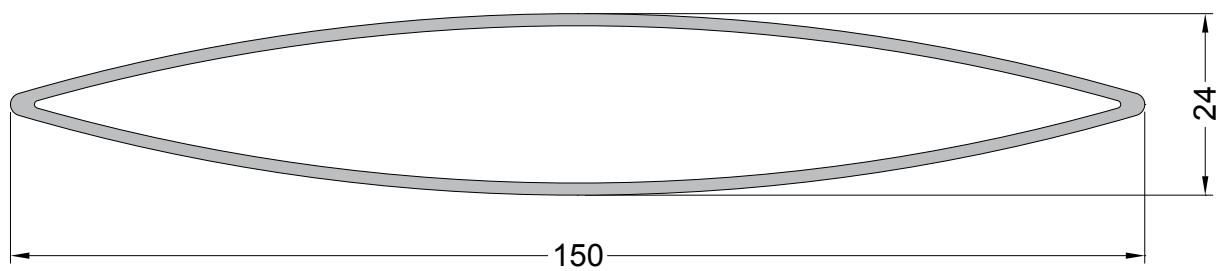

D-054 (DC-006)

0.834 Kg/m

Brise

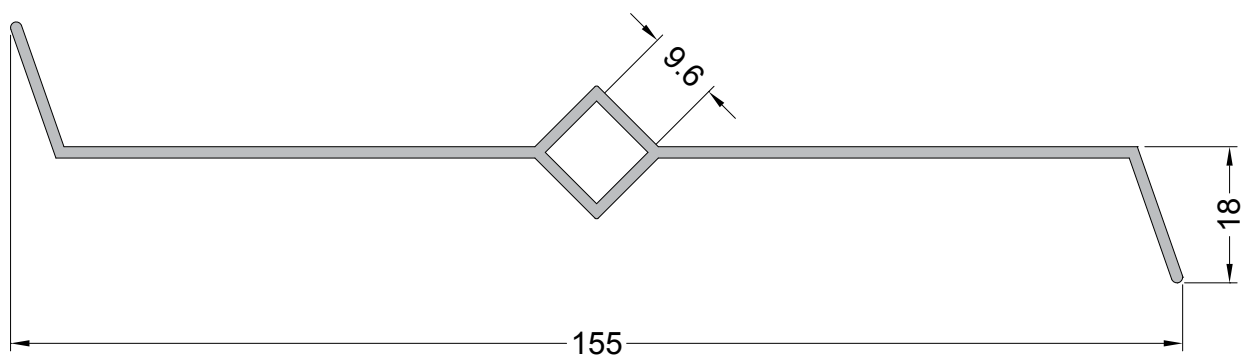

BR-74601  
0.587 Kg/m  
Suporte - La Brise

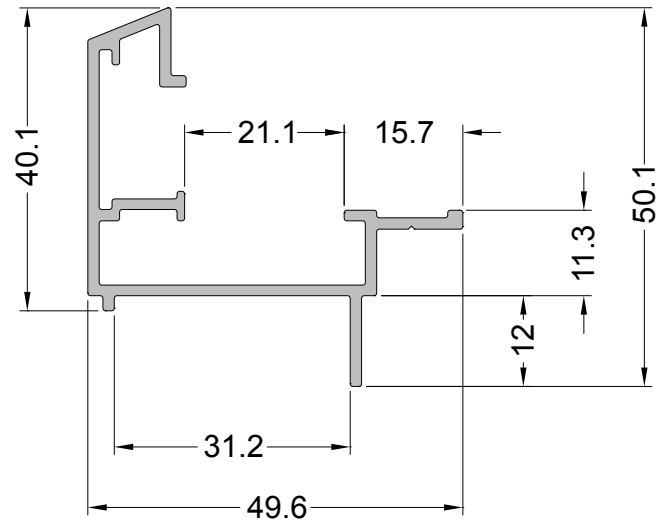

BR-74602  
0.695 Kg/m  
Suporte - La Brise

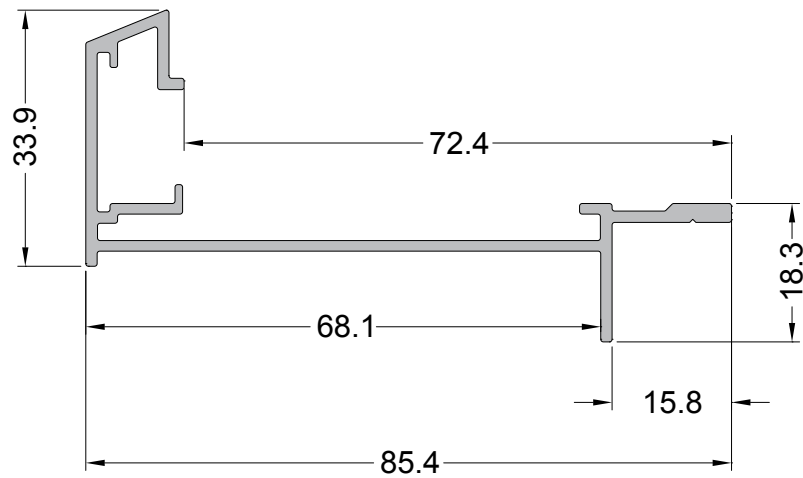

BR-75301  
0.402 Kg/m  
Suporte - La Brise

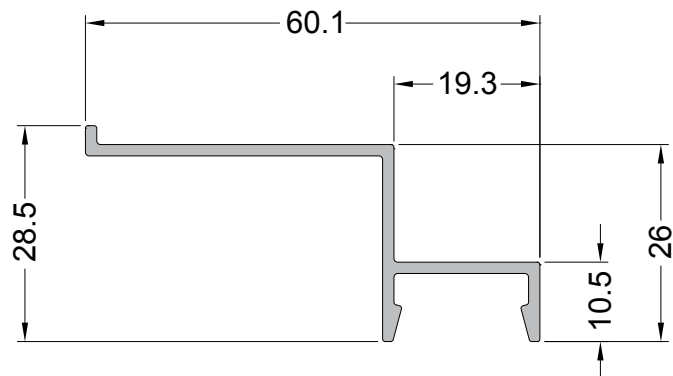

BR-75302

0.872 Kg/m

Brise - La Brise

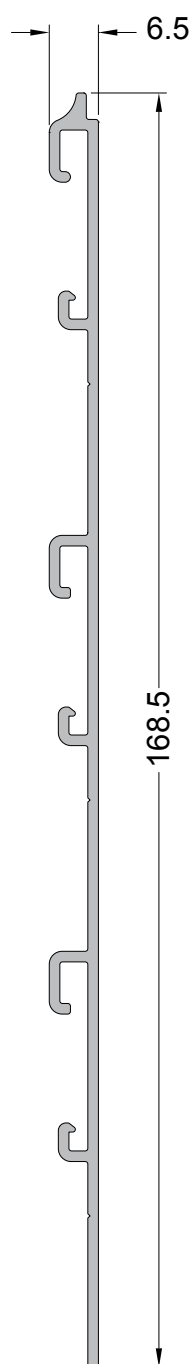

BR-75903

0.655 Kg/m

Veneziana

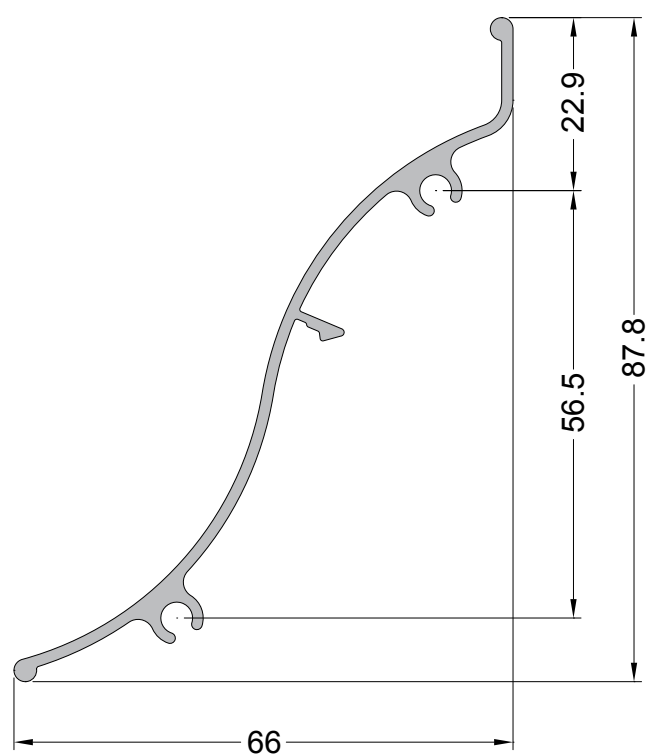

CX-3282  
1.356 Kg/m  
Lambri

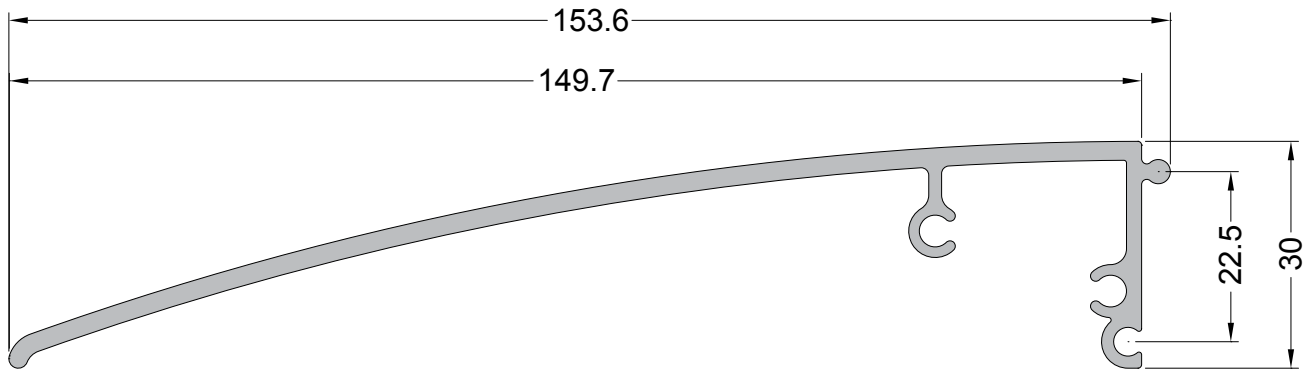

CX-3283  
1.438 Kg/m  
Lambri

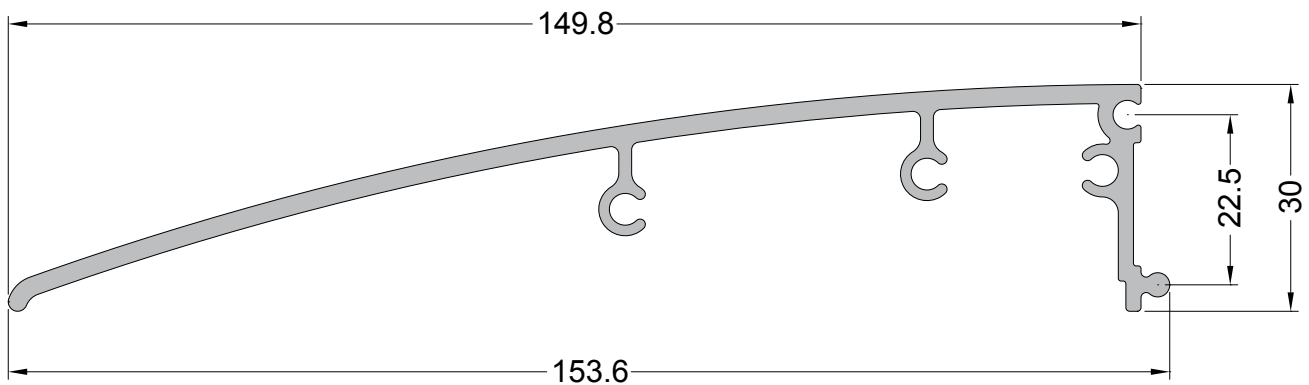



CX-559 (BX-095)

0.601 Kg/m

Trilho Superior

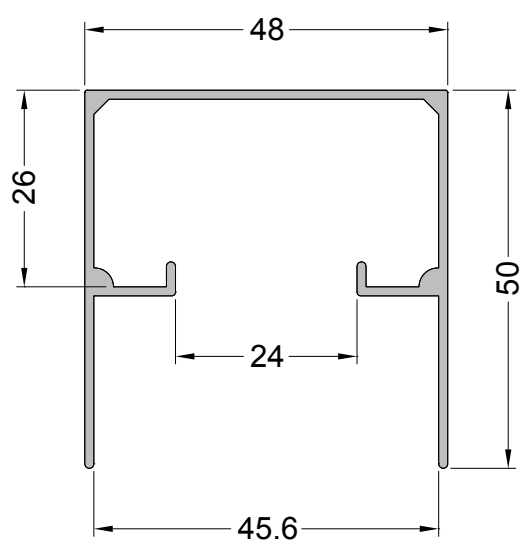

U-397

0.713 Kg/m

Box

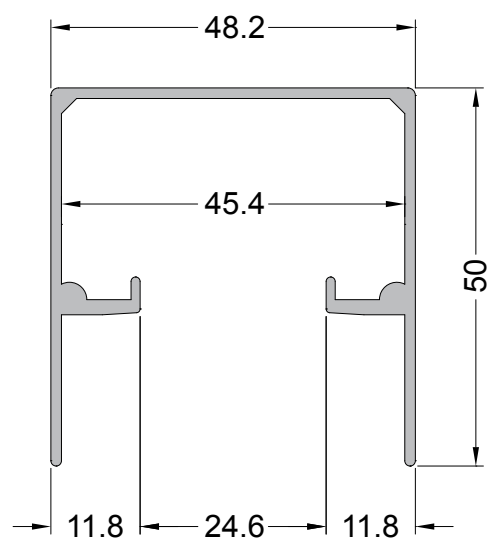

E-117

0.320 Kg/m

Guia Inferior

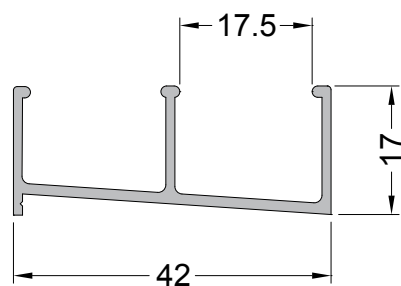

BX-056

0.218 Kg/m

Guia

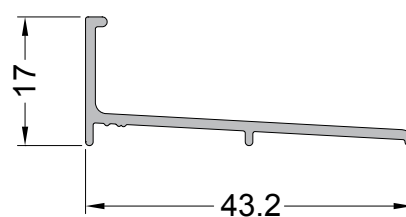

U-399 (BX-093)

0.274 Kg/m

Marco

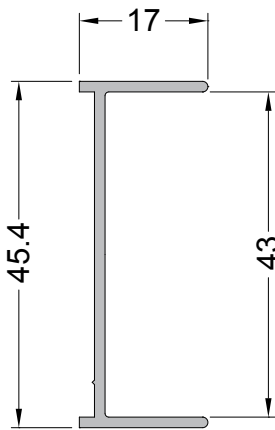

U-1244 (BX-093)

0.227 Kg/m

Marco

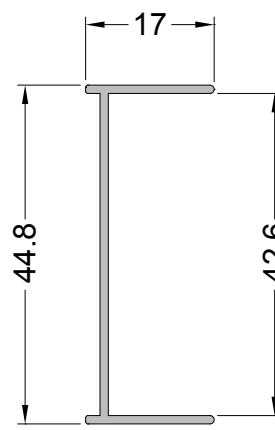

BX-123

0.204 Kg/m

Folha

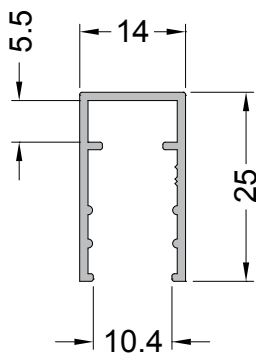

U-396

0.176 Kg/m

Folha

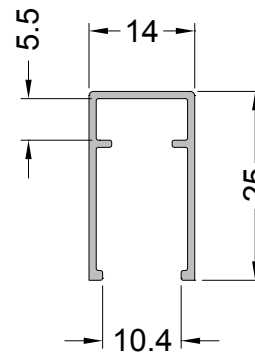

BX-103

0.155 Kg/m

Folha

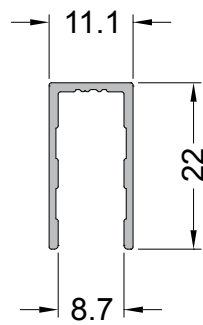

BX-137

0.162 Kg/m

Folha

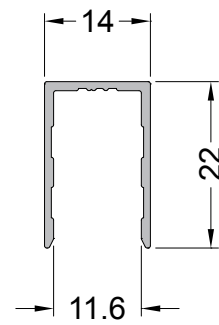

BX-057

0.254 Kg/m

Travessa

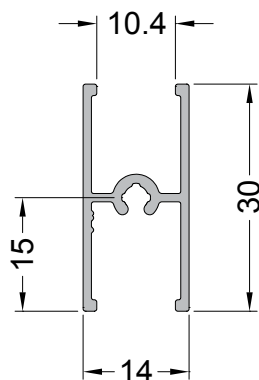

Y-106 (BX-007)

0.310 Kg/m

Folha

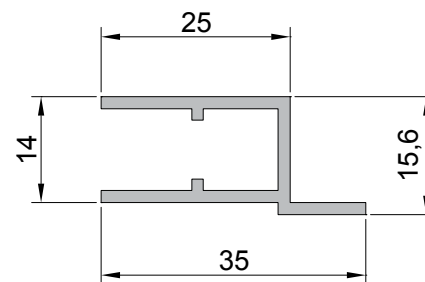

BX-097  
0.490 Kg/m  
Trilho Superior

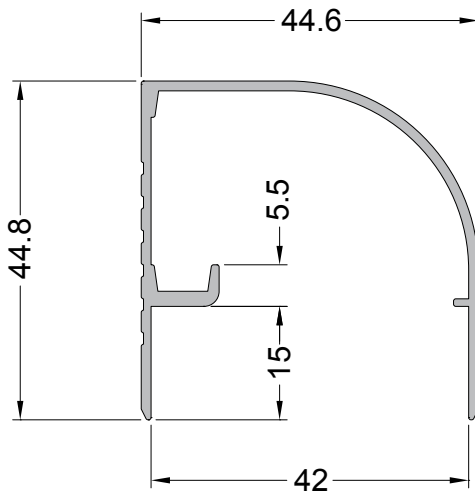

E-256 (BX-175)  
0.323 Kg/m  
Guia Inferior

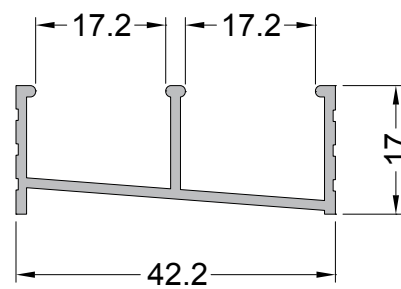

U-653 (BX-174)  
0.244 Kg/m  
Marco

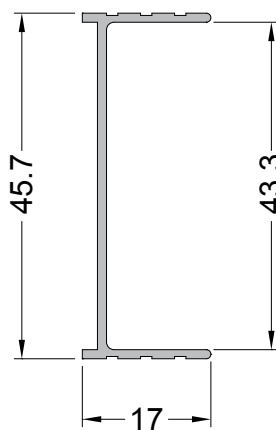

U-2109  
0.180 Kg/m  
Marco

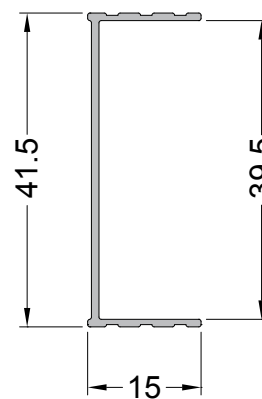

U-1002 (BX-158)

0.171 Kg/m

Folha

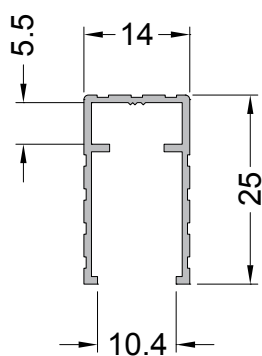

U-2111

0.155 Kg/m

Folha

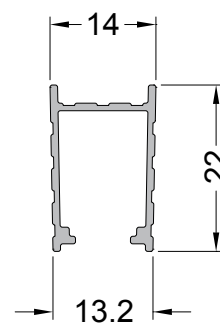

BX-090

0.290 Kg/m

Travessa

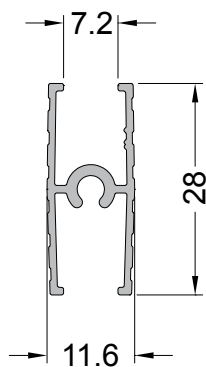

I-154 (BX-159)

0.307 Kg/m

Travessa

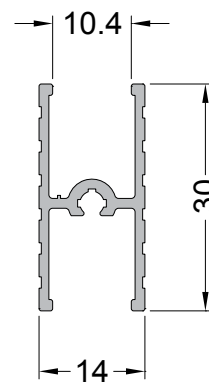

U-654

0.198 Kg/m

Perfil "U" - Regulagem

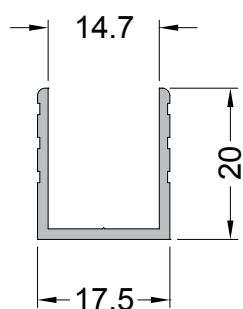

BX-2000  
0.652 Kg/m  
Trilho Superior

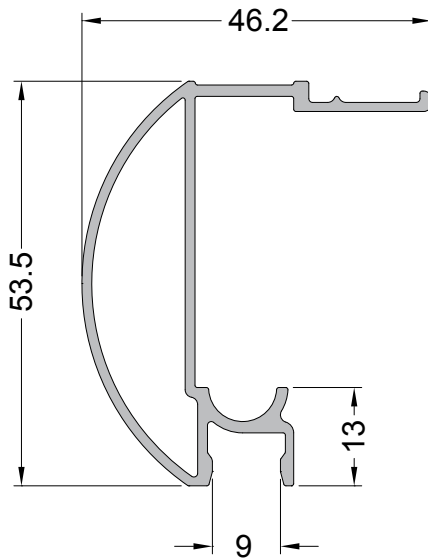

CL-058  
0.830 Kg/m  
Trilho Superior

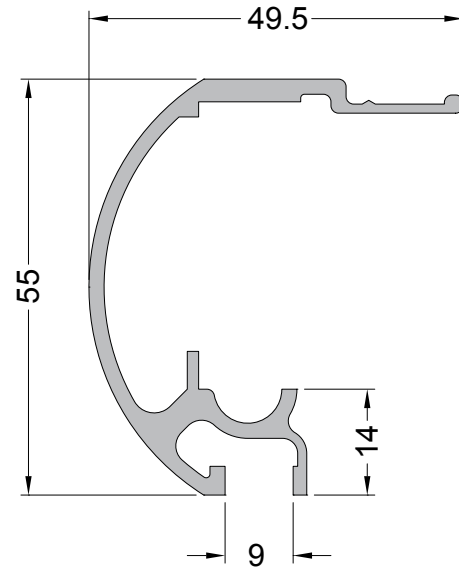

L-537 (BX-239)  
1.274 Kg/m  
Trilho Superior

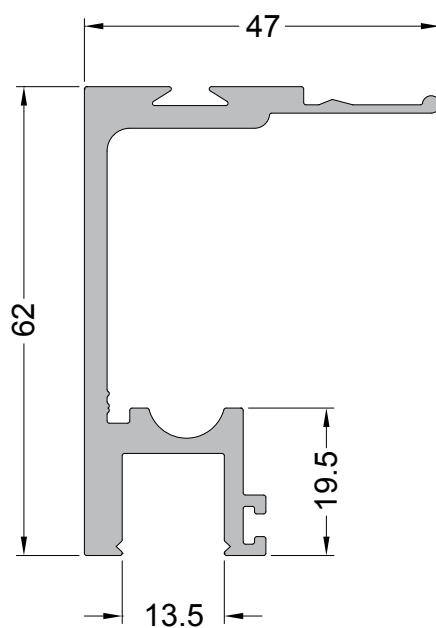

L-1051  
0.792 Kg/m  
Trilho Superior

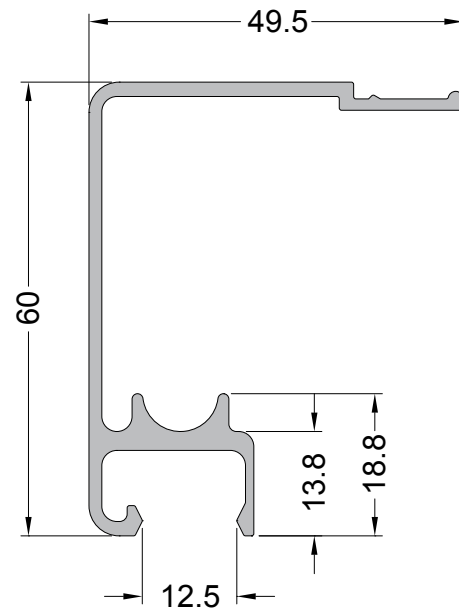

U-1319 (BX-184)

0.258 Kg/m

Capa do Trilho

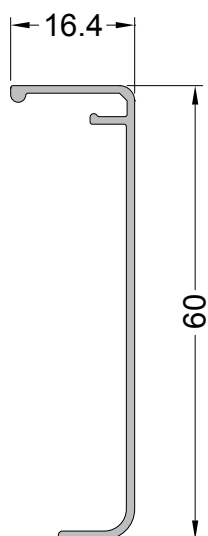

CX-497

0.256 Kg/m

Capa do Trilho

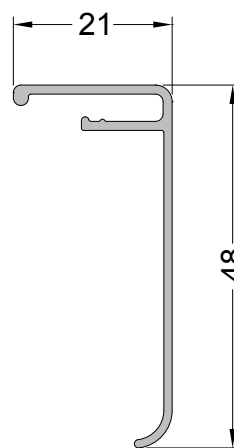

E-512

0.434 Kg/m

Capa do Trilho

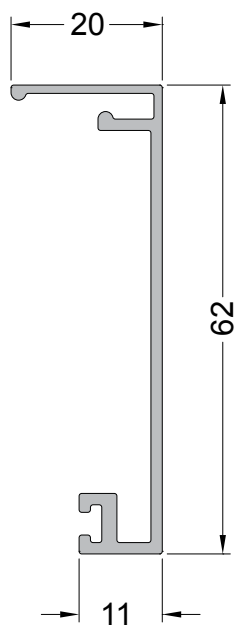

U-1108 (BX-069)

0.357 Kg/m

Guia

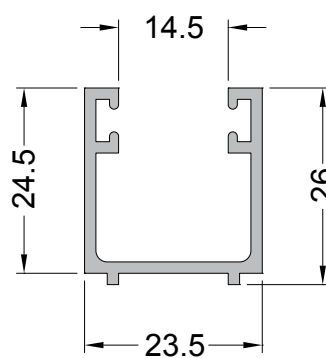

BX-150  
0.745 Kg/m  
Guia Inferior

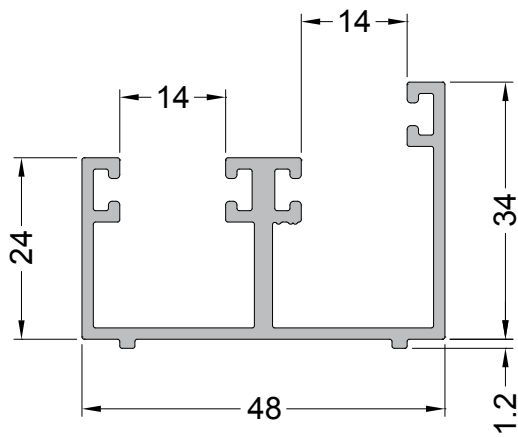

Medidas Aproximadas

CL-061  
0.455 Kg/m  
Guia Inferior

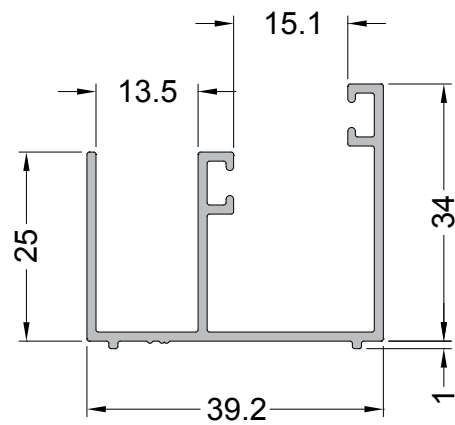

E-306 (BX-240)  
0.484 Kg/m  
Guia Inferior

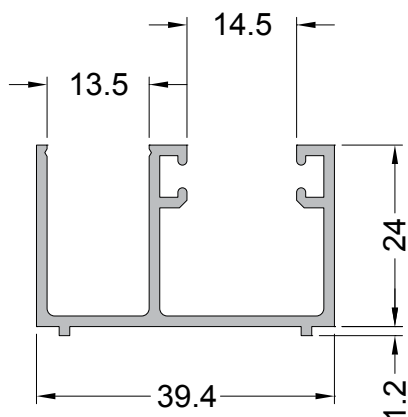

U-1014 (BX-241)  
0.256 Kg/m  
Folha

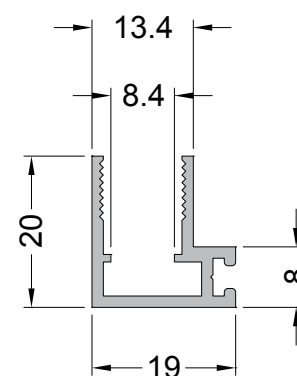



Y-1047 (CB-266)

0.267 Kg/m

Batedeira

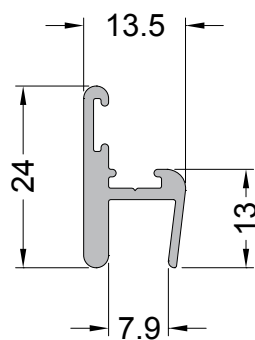

U-1015

0.197 Kg/m

Folha

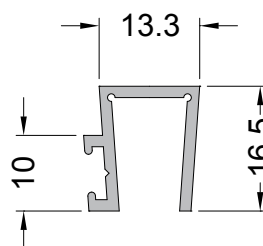

BX-096

0,183 Kg/m

Baguete

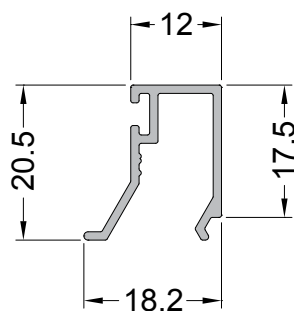

U-491 (CL-022)

0.099 Kg/m

Tampa

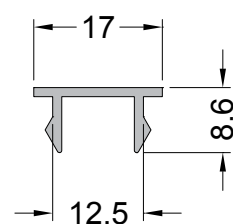

DV-055  
0.276 Kg/m  
Divisória

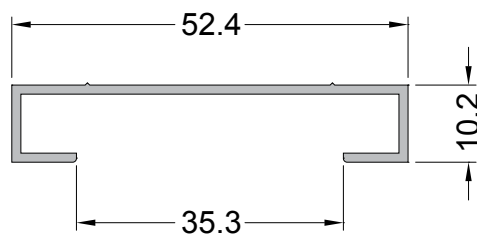

DV-111  
0.188 Kg/m  
Divisória

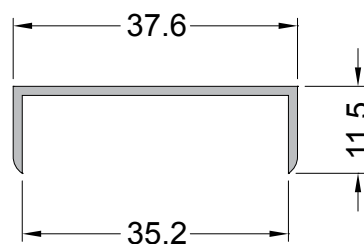

DV-129  
0.405 Kg/m  
Divisória

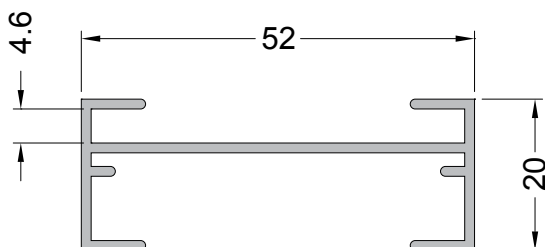

DV-132  
0.254 Kg/m  
Travessa

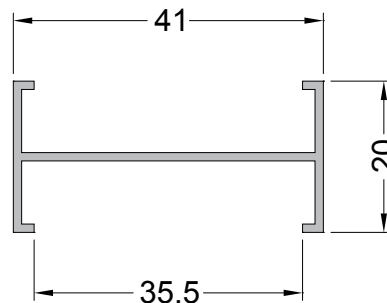

DV-405  
0.329 Kg/m  
Pux. para Móveis

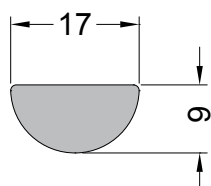

DV-406  
0.533 Kg/m  
Pux. para Móveis

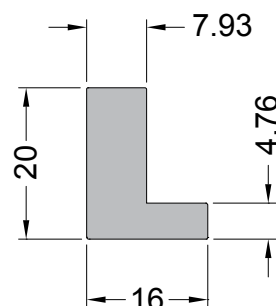

DV-436

0.362 Kg/m

Divisória

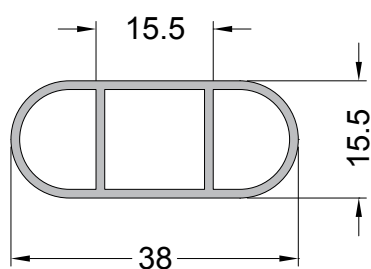

DV-208

0.316 Kg/m

Batente

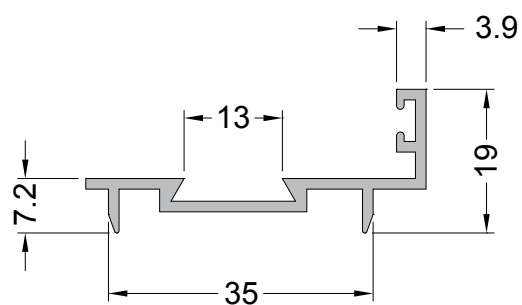

DV-113

0.252 Kg/m

Palheta

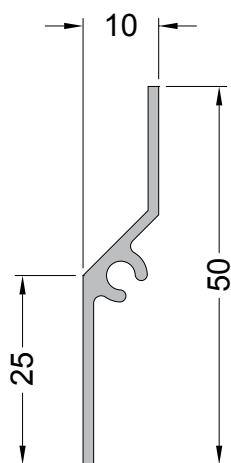

DV-101 (DV-055)

0.636 Kg/m

Divisória

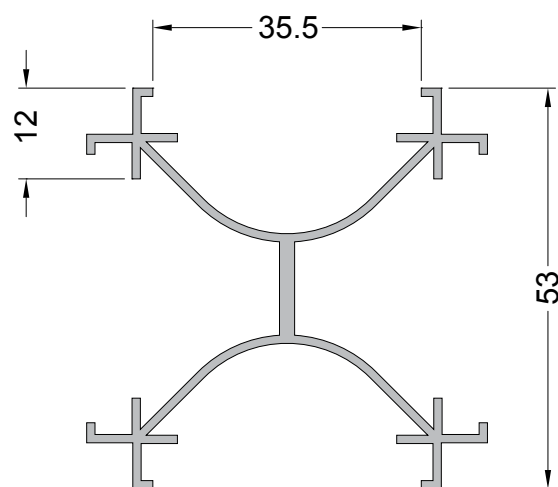

DV-444  
0.695 Kg/m  
Rodapé

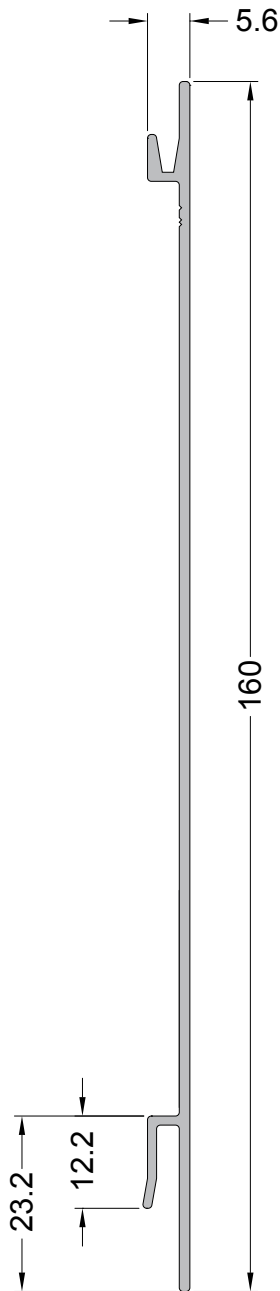

U-522 (BG-001)  
0.101 Kg/m  
Baguete

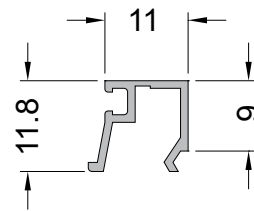

BG-013  
0.122 Kg/m  
Baguete

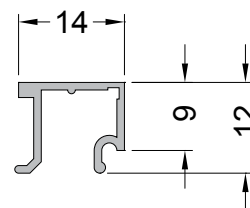

DV-459  
0.900 Kg/m  
Batente

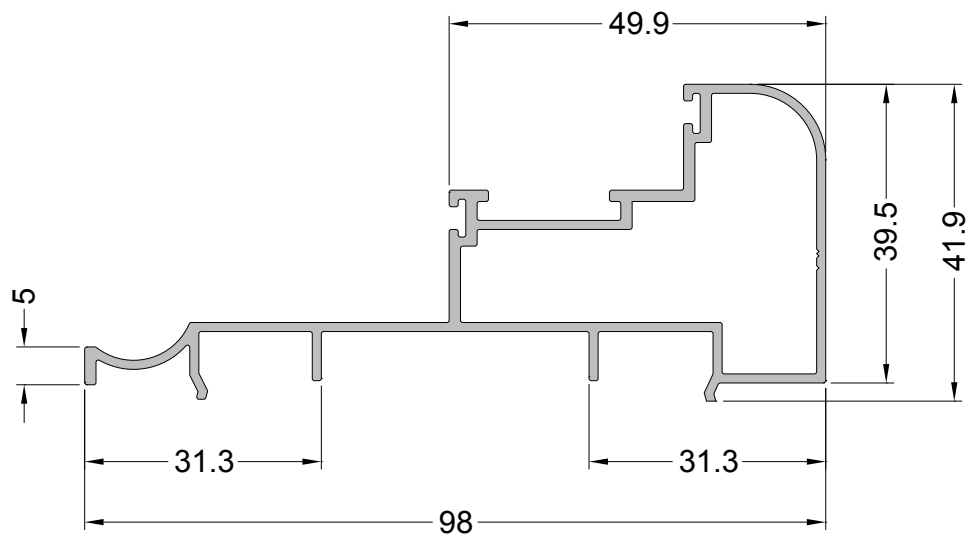

DV-460  
1.469 Kg/m  
Guia de Teto

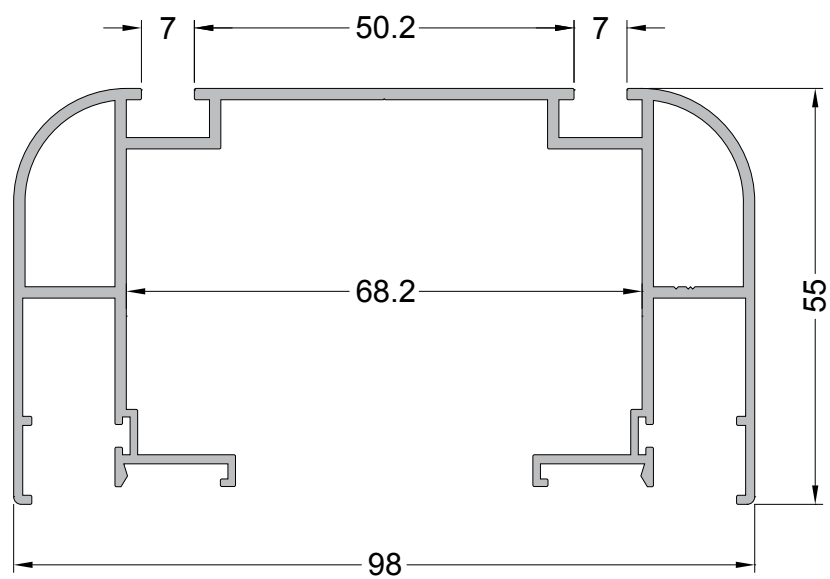

DV-461  
1.835 Kg/m  
Coluna Quadrada

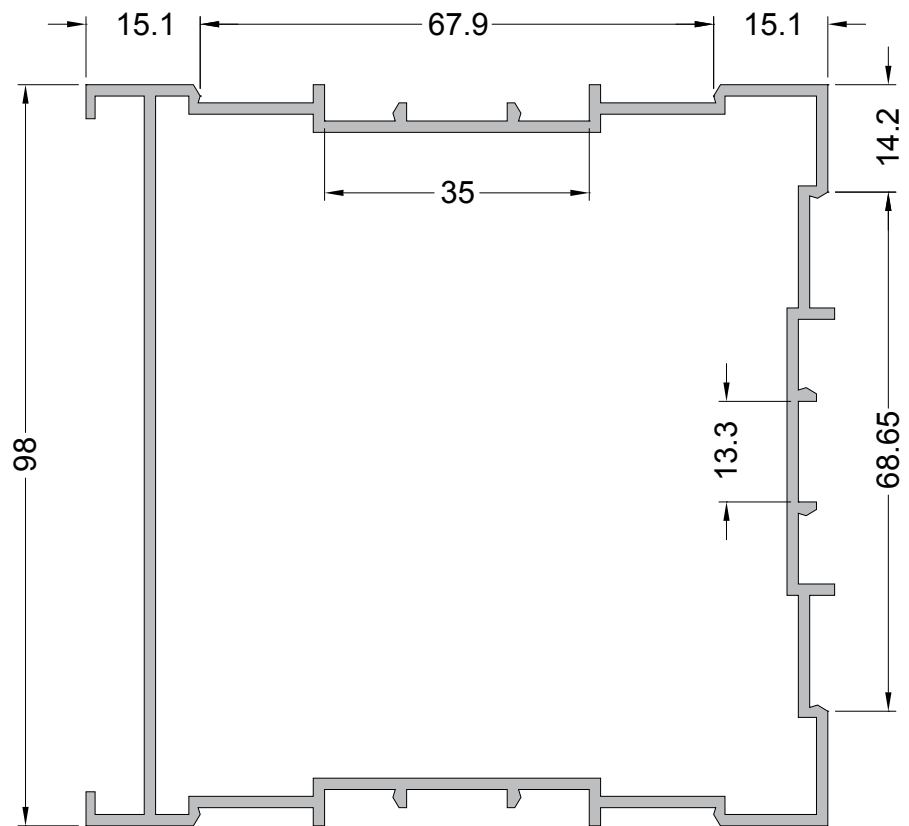

DV-300  
1.243 Kg/m  
Divisória (Sanitária)

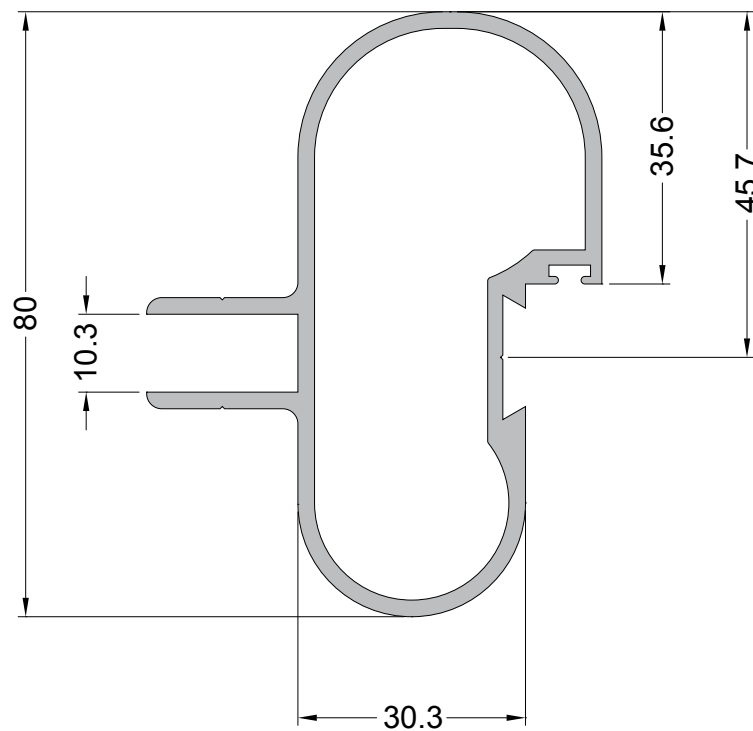

CX-3257  
0.432 Kg/m  
Tubo

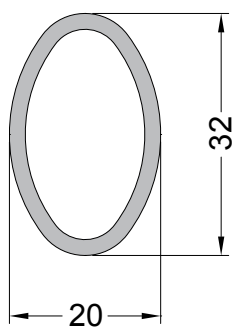

A-058  
0.200 Kg/m  
Diversos

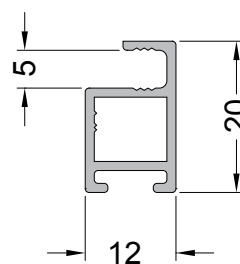

CX-531  
0.149 Kg/m  
Base de Articulação

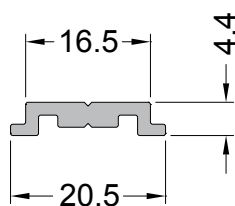

DS-036  
0.151 Kg/m  
Diversos

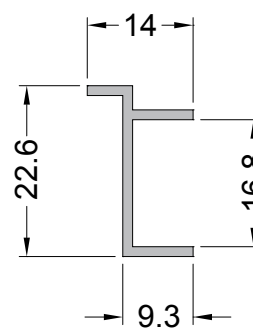

L-631 (DS-143)

0.235 Kg/m

Diversos

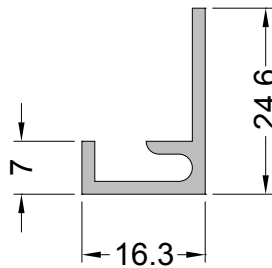

T-180

0.131 Kg/m

Perfil T

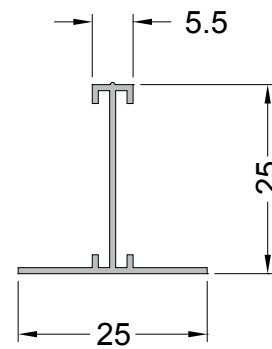

T-215

0.157 Kg/m

Perfil T

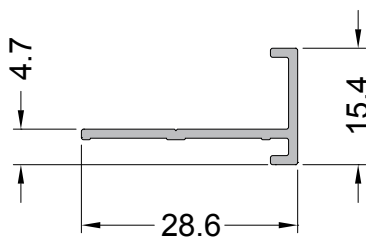

T-214

0.213 Kg/m

Perfil T

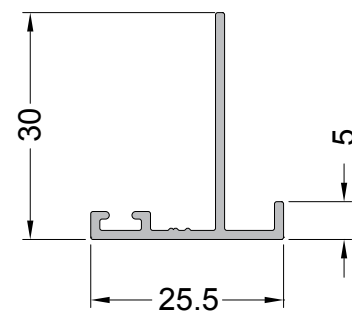



PU-800

0.071 Kg/m

Perfil U

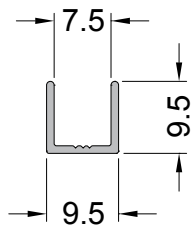

VG-250  
0,458 Kg/m  
Marco Superior

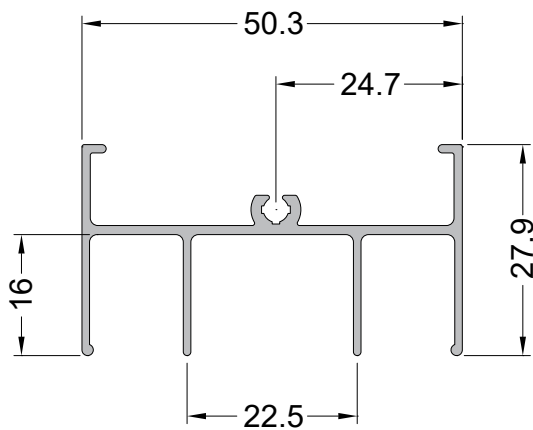

VG-210  
0,469 Kg/m  
Marco Inferior

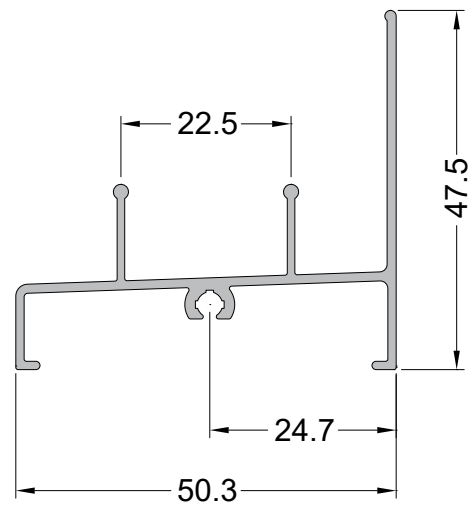

VG-215  
0,437 Kg/m  
Marco Inferior

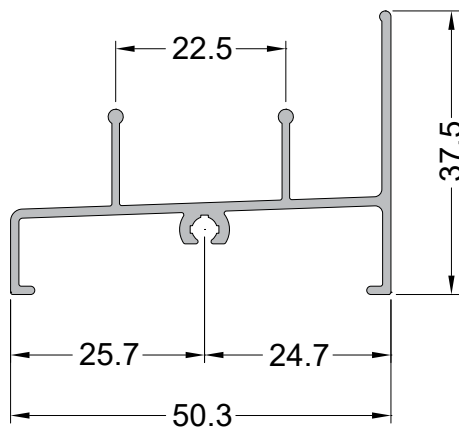

ALG-989  
0,308 Kg/m  
Marco Superior

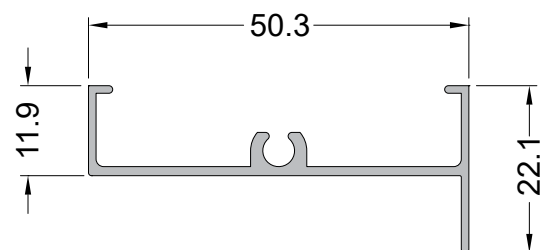

ALG-988  
0,775 Kg/m  
Travessa Bandeira

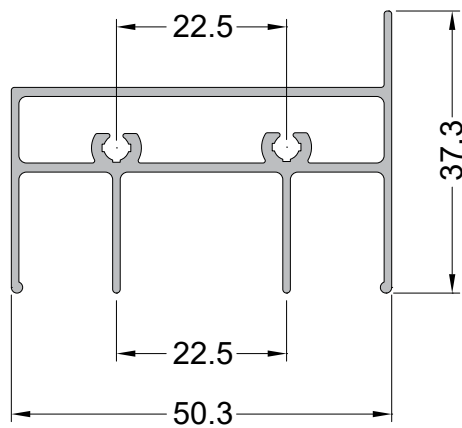

ALG-987  
0,707 Kg/m  
Travessa Peitoril

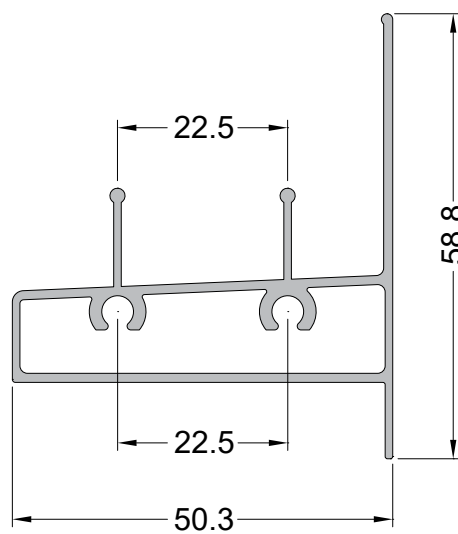

CX-3033  
0,533 Kg/m  
Marco Superior

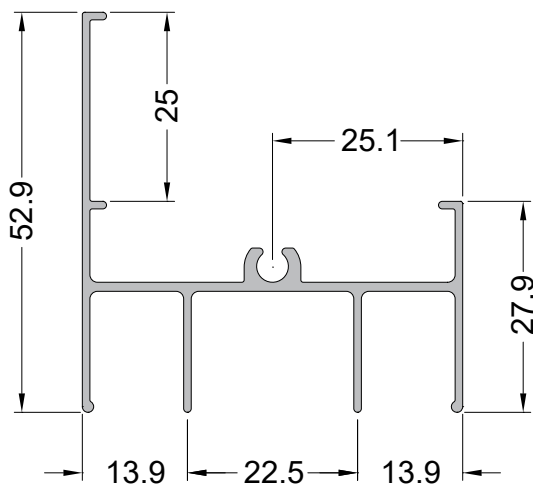

CX-3034  
0,542 Kg/m  
Marco Inferior

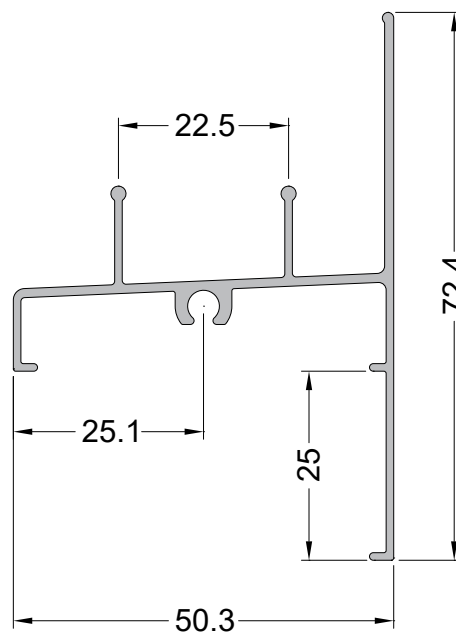

VG-251  
0,500 Kg/m  
Marco Superior

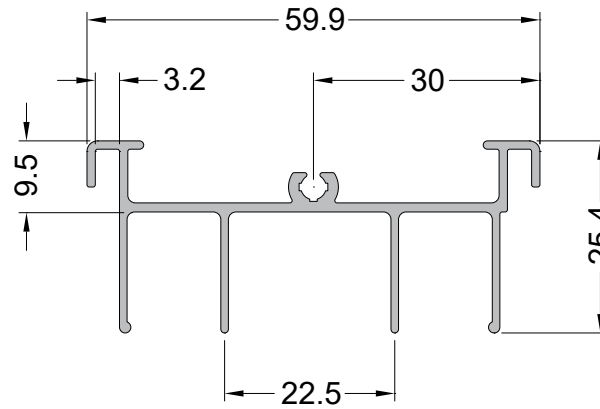

VG-216  
0,479 Kg/m  
Marco Inferior

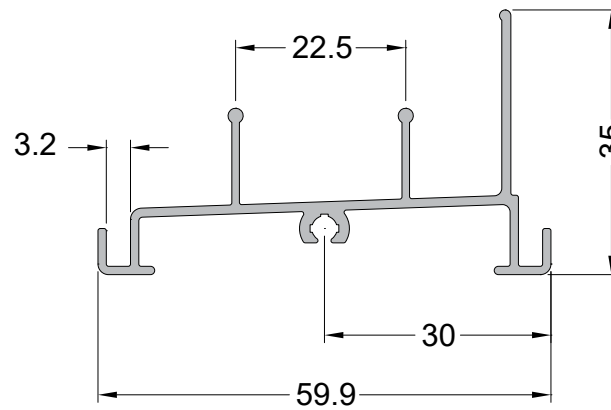

VG-211  
0,511 Kg/m  
Marco Inferior

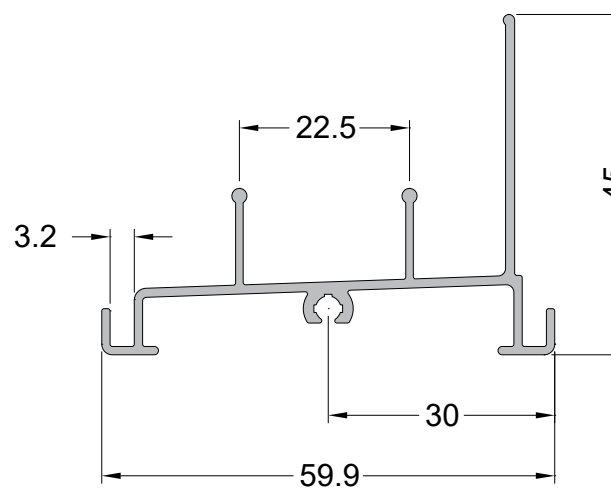

PERFIS, PROJETOS, CÓDIGOS E SISTEMAS ESTÃO SUJEITOS A ALTERAÇÃO SEM AVISO PRÉVIO.

VG-271  
0,349 Kg/m  
Marco Lateral

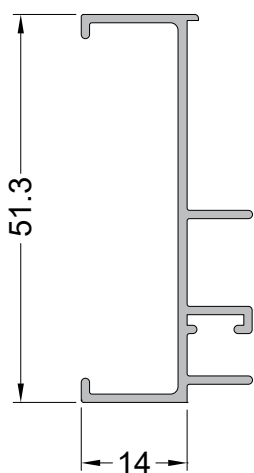

VG-272  
0,349 Kg/m  
Marco Lateral

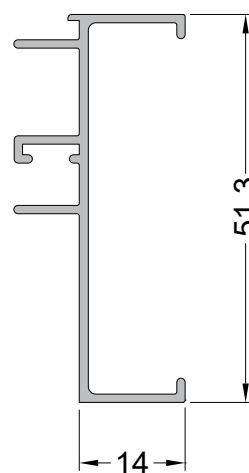

VG-273  
0,370 Kg/m  
Marco Lateral

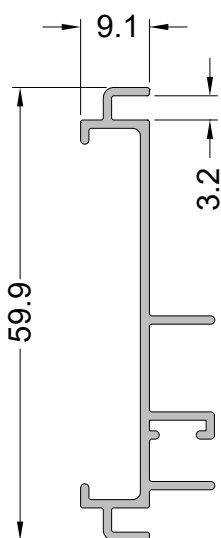

VG-274  
0,370 Kg/m  
Marco Lateral

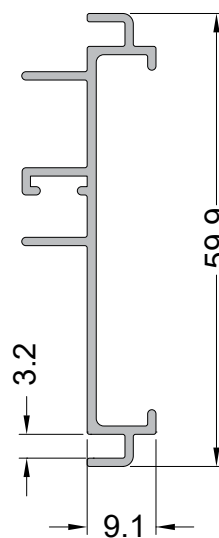

VG-270  
0,259 Kg/m  
Marco Lateral

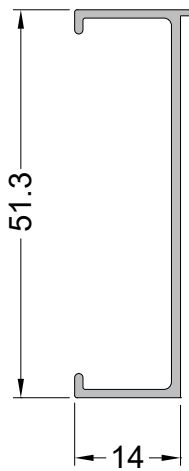

CX-3035  
0.367 Kg/m  
Marco Lateral

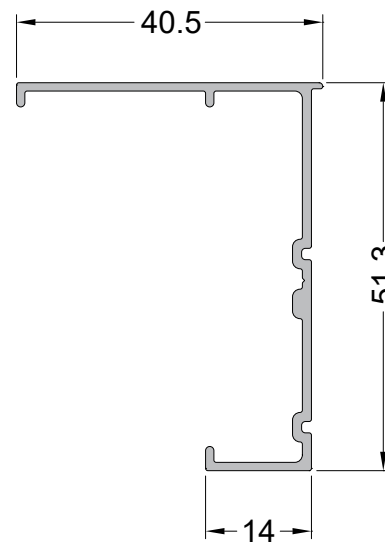

VG-20201  
0,362 Kg/m  
Marco

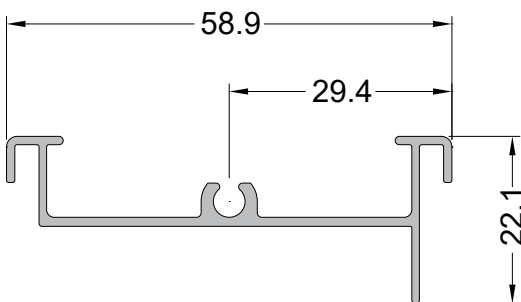

VG-40301  
0,312 Kg/m  
Marco Lateral

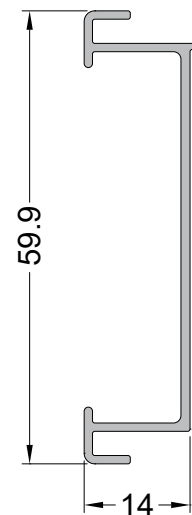

VG-350  
0,651 Kg/m  
Marco Superior

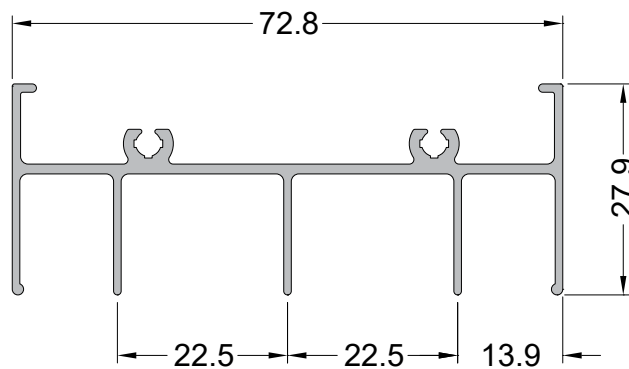

VG-310  
0,614 Kg/m  
Marco Inferior

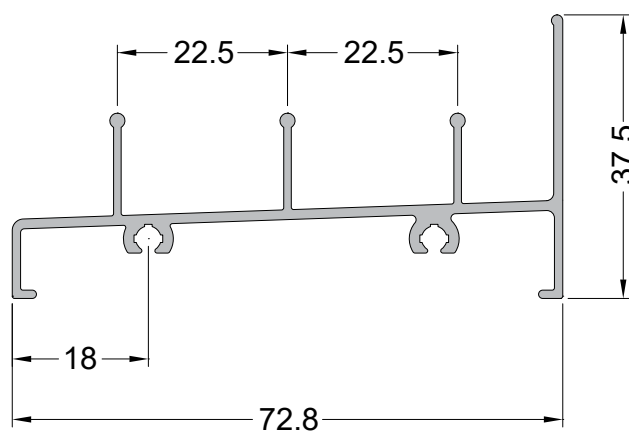

VG-315  
0,647 Kg/m  
Marco Inferior

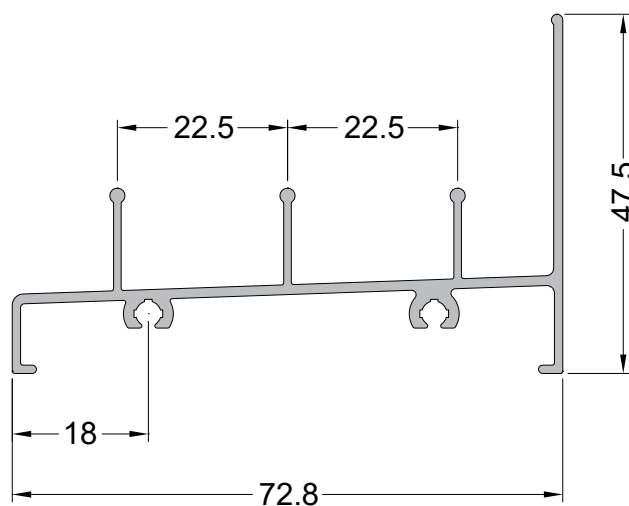

VG-351  
0,693 Kg/m  
Marco Superior

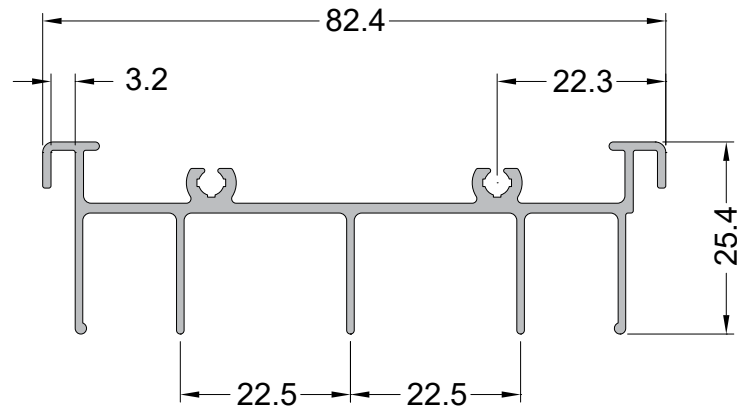

VG-311  
0,656 Kg/m  
Marco Inferior

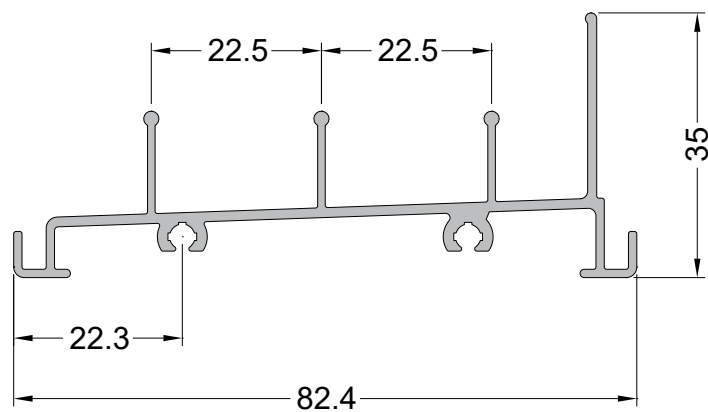

VG-316  
0,689 Kg/m  
Marco Inferior

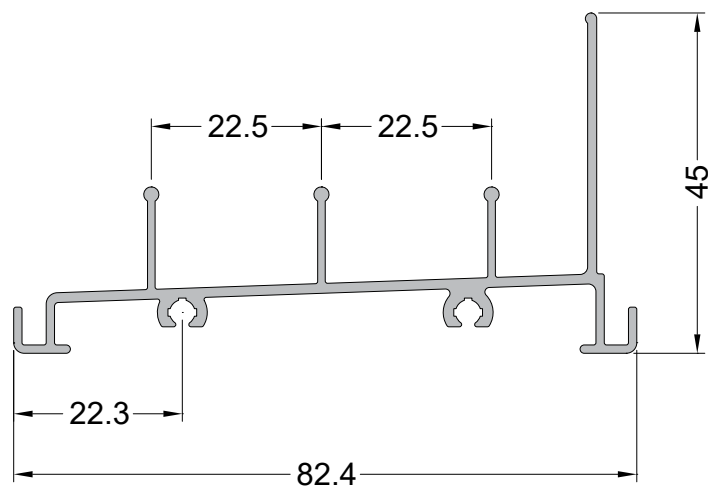



VG-371  
0,449 Kg/m  
Marco Lateral

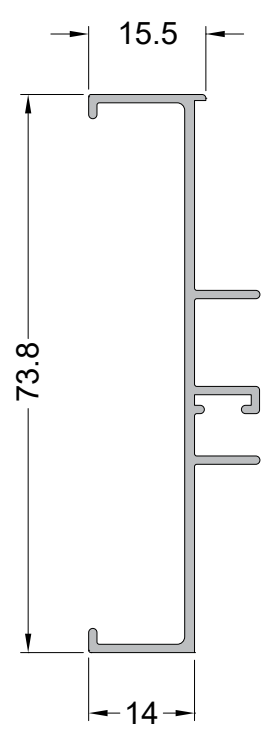

VG-372  
0,532 Kg/m  
Marco Lateral

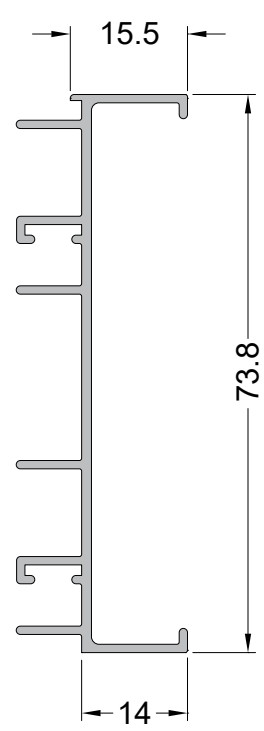

VG-373  
0,463 Kg/m  
Marco Lateral

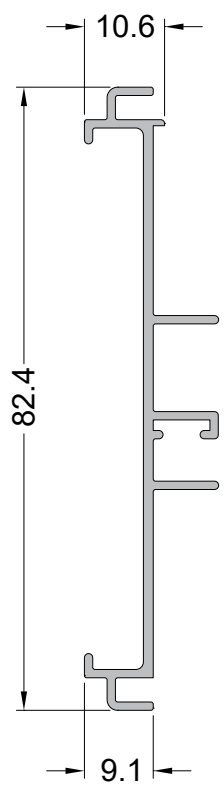

VG-374  
0,553 Kg/m  
Marco Lateral

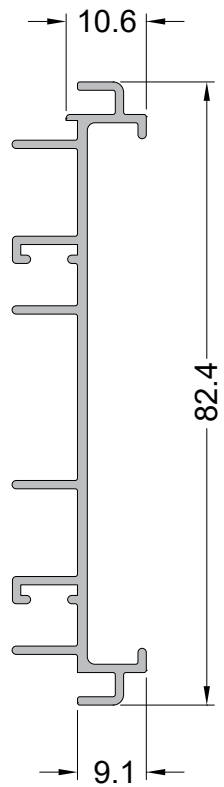

VG-370  
0,351 Kg/m  
Marco Lateral

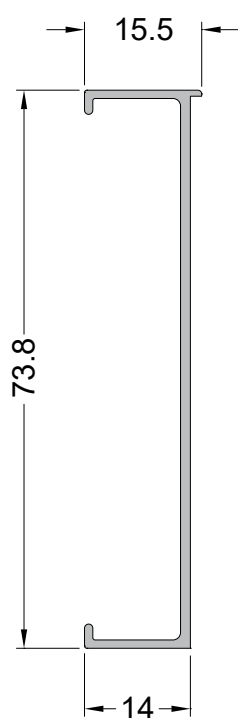

VG-970  
0,161 Kg/m  
Mata-Junta

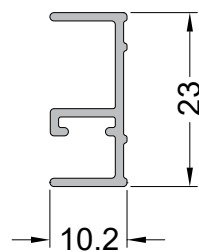

ALG-1001  
0,747 Kg/m  
Marco Superior

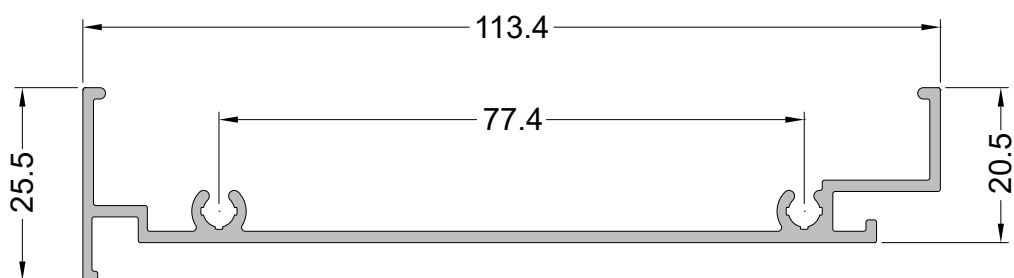

ALG-921  
0,677 Kg/m  
Marco Intermediário

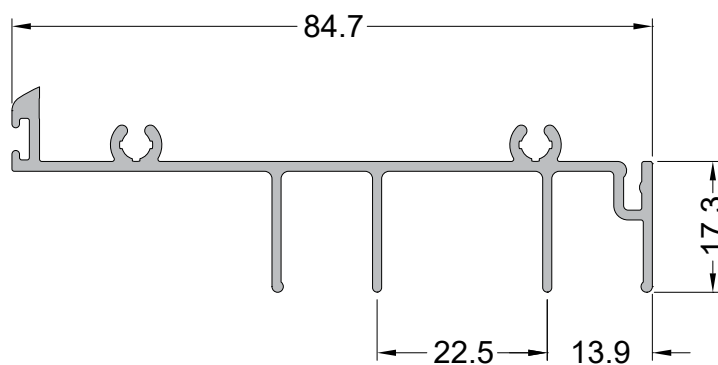

ALG-922  
0,861 Kg/m  
Marco Inferior

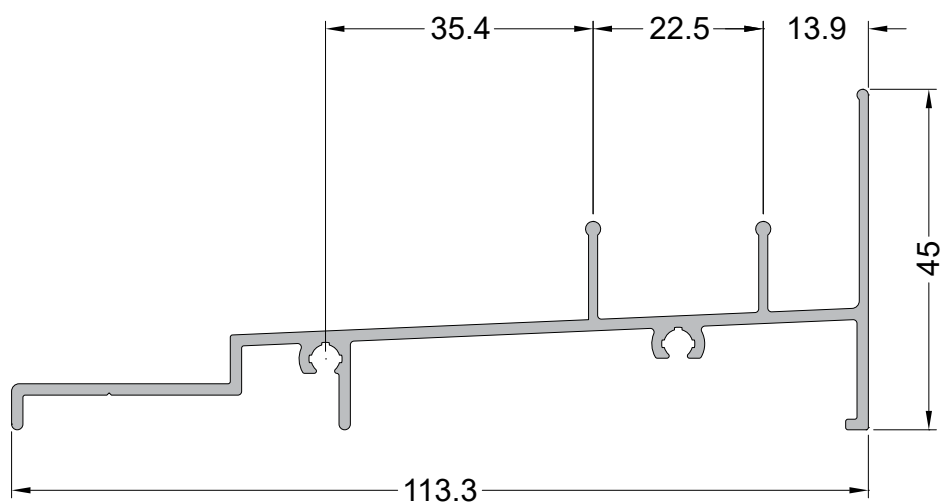

ALG-1000  
0,573 Kg/m  
Marco

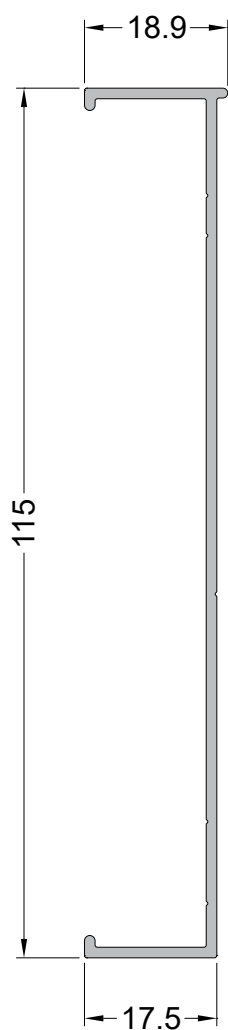

ALG-1012  
0.719 Kg/m

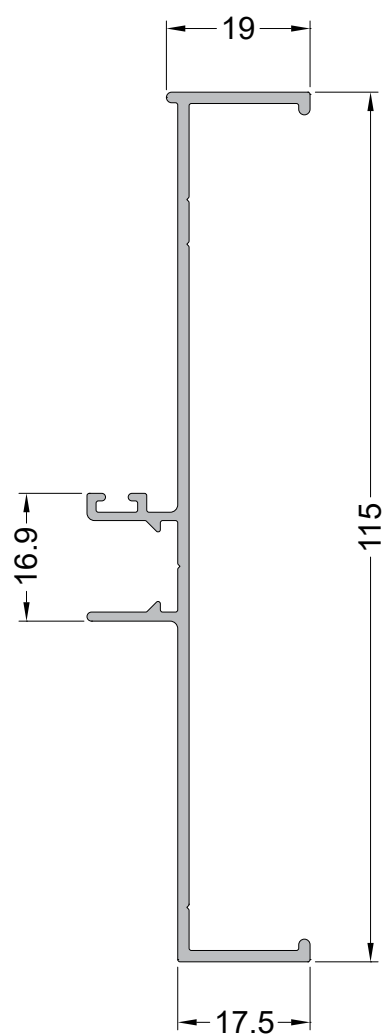

ALG-1004  
0,906 Kg/m  
Marco Lateral

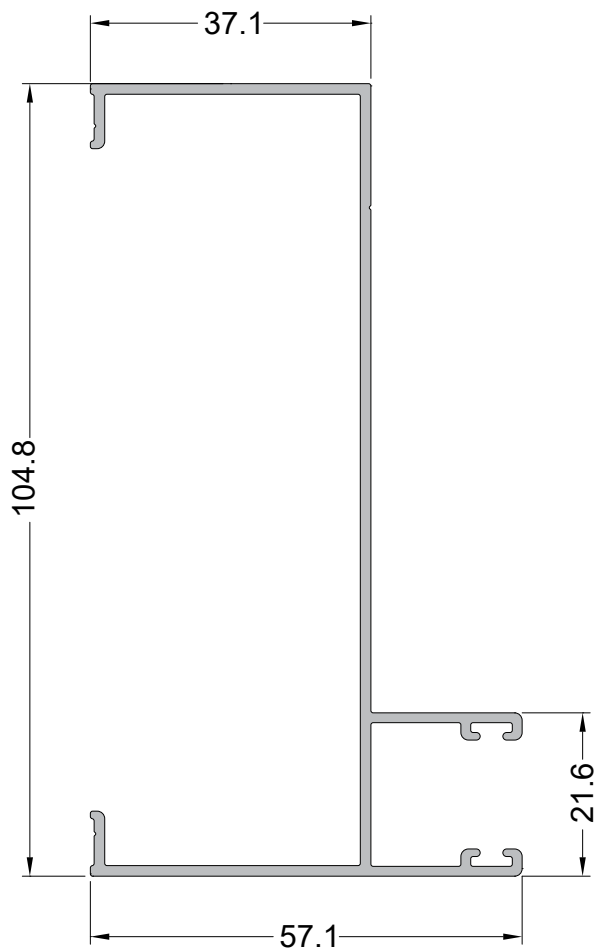

ALG-1011  
1.014 Kg/m  
Marco Lateral

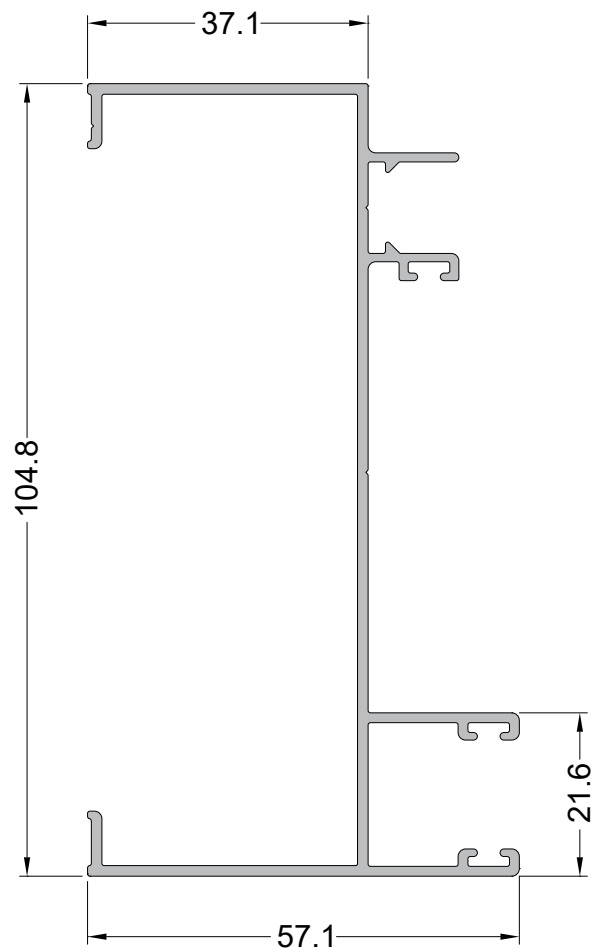

ALG-1007  
0,867 Kg/m  
Tampa Externa

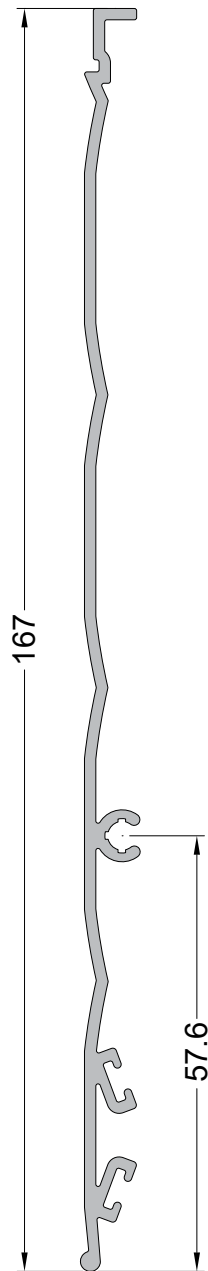

ALG-1010  
1,080 Kg/m  
Tampa Externa

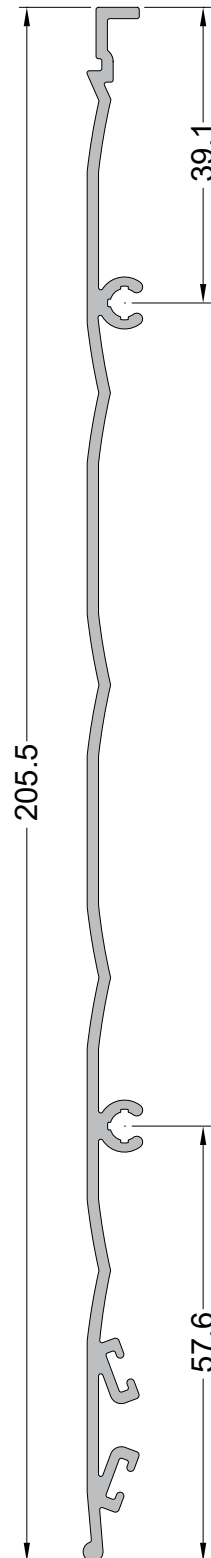

ALG-1041  
0,949 Kg/m  
Tampa Interna

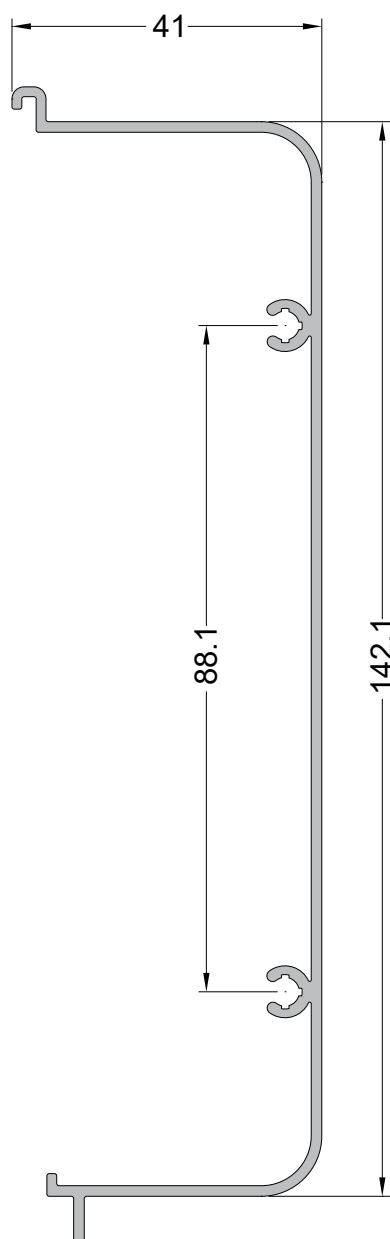

ALG-1006  
0,937 Kg/m  
Tampa Interna

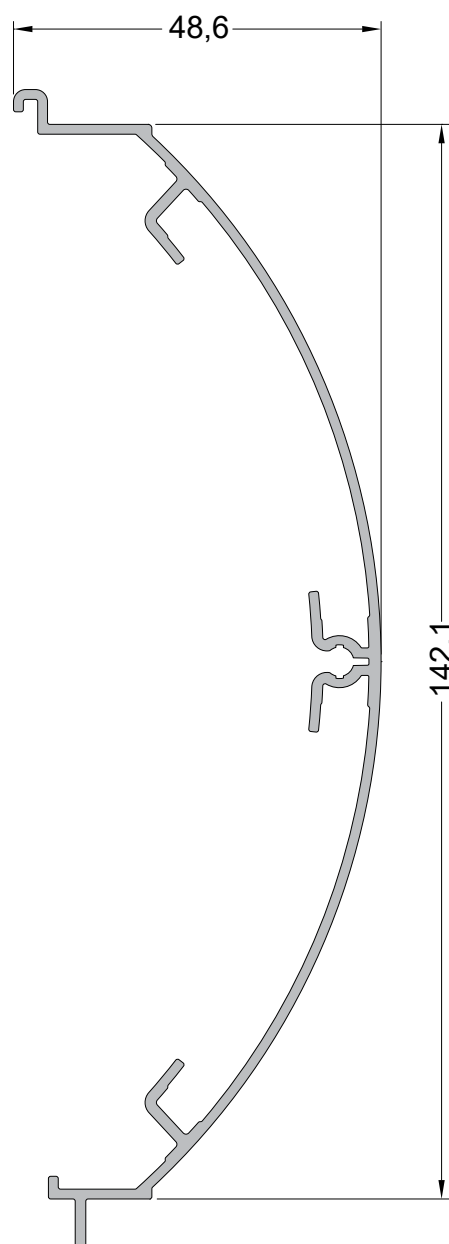

ALG-1042  
1,967 Kg/m  
Tampa Interna

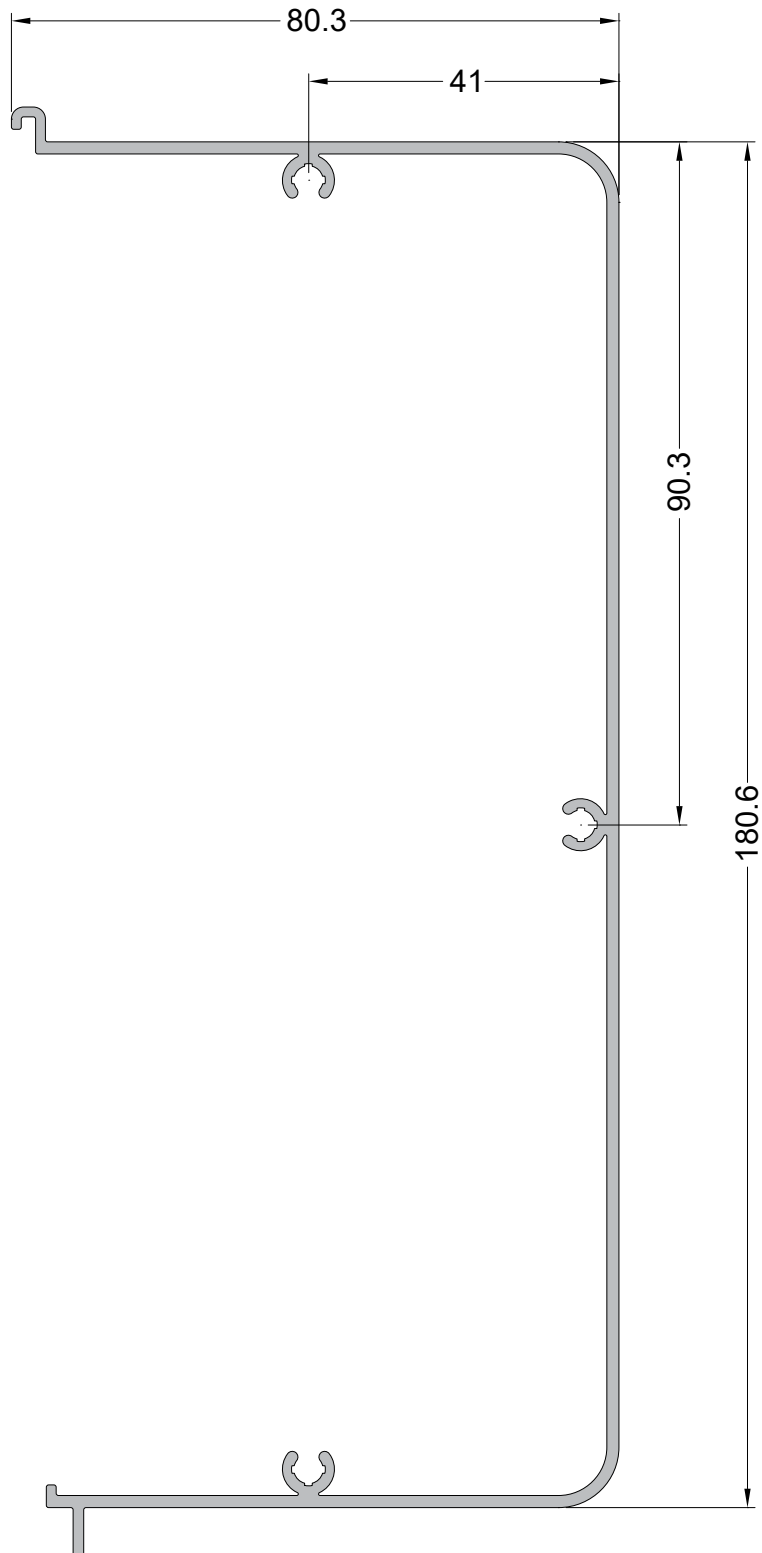



ALG-1009  
1,260 Kg/m  
Tampa Interna

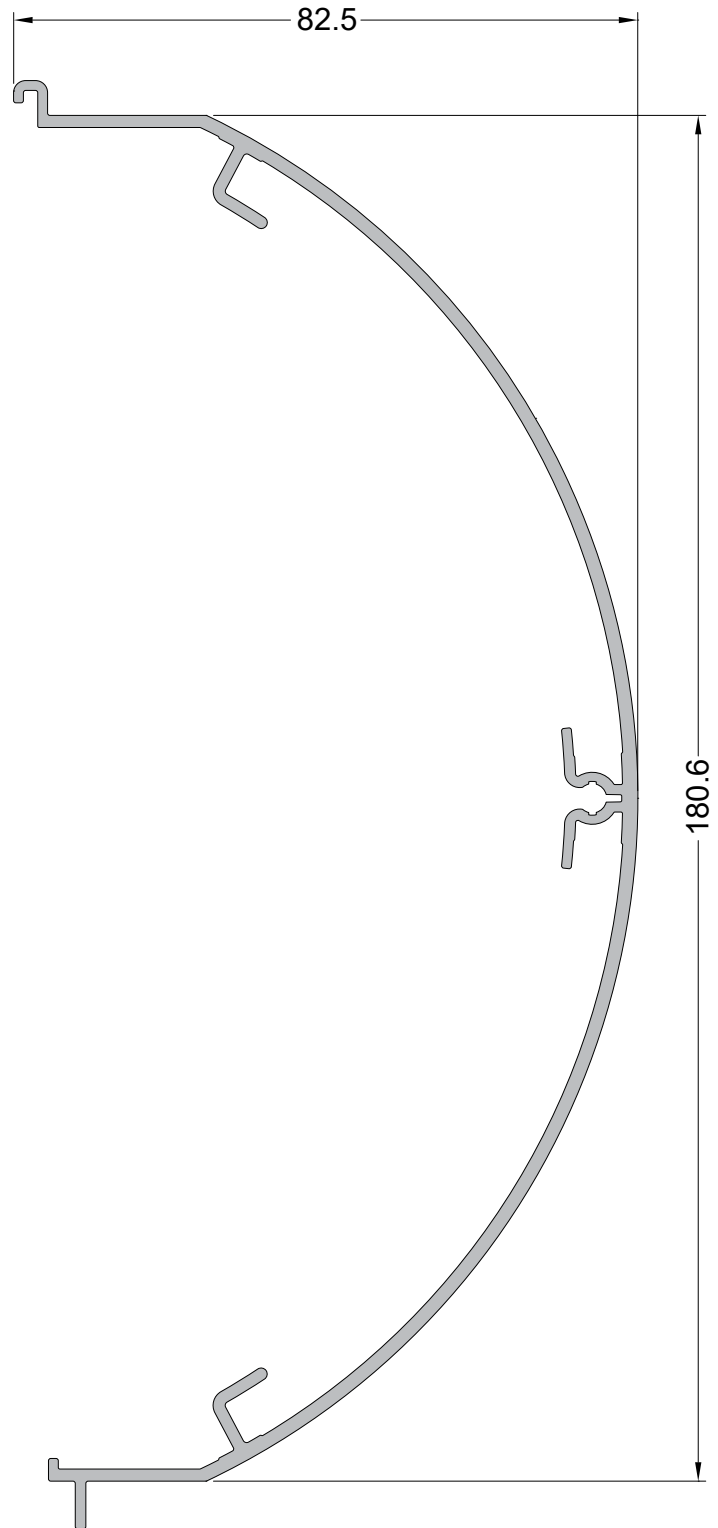

DS-238

0,485 Kg/m

Tubo Recolhedor

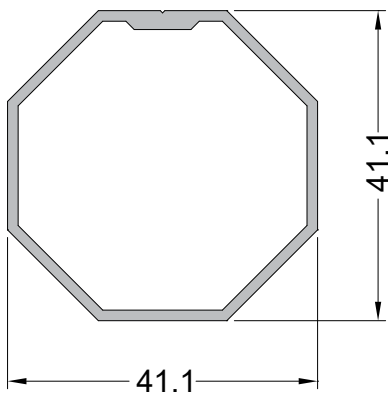

ALG-1008

0,866 Kg/m

Guia Central

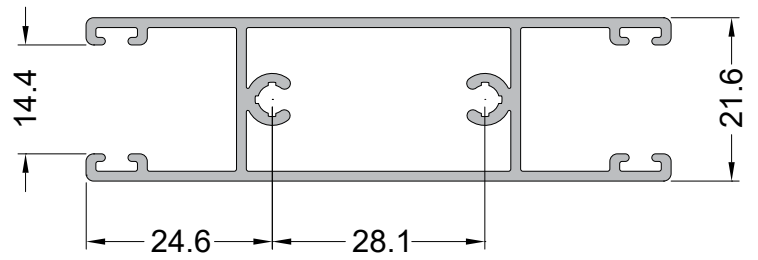

ALG-1005

0,577 Kg/m

Guia da Persiana

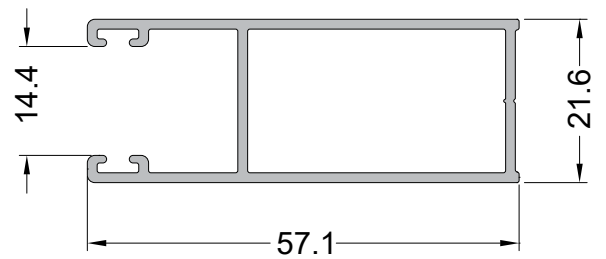

MN-015

0.843 Kg/m

Tubo Recolhedor

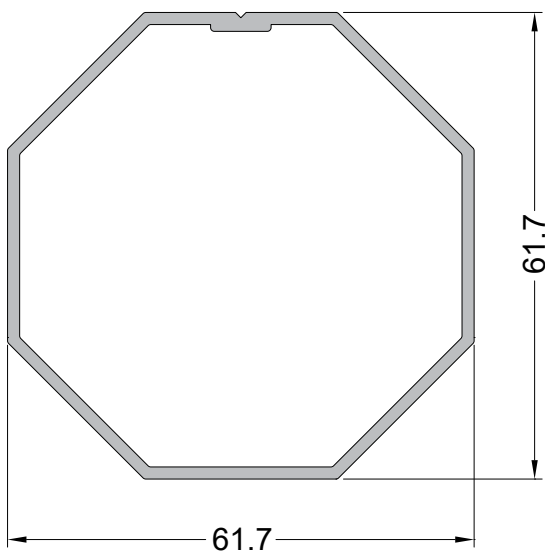

MN-055

0,376 Kg/m

Terminal

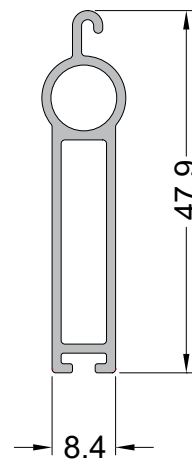

PERFIS, PROJETOS, CÓDIGOS E SISTEMAS ESTÃO SUJEITOS A ALTERAÇÃO SEM AVISO PRÉVIO.

VG-610

0,352 Kg/m

Folha horizontal

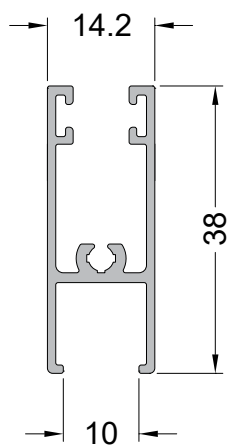

VG-665

0,379 Kg/m

Folha horizontal

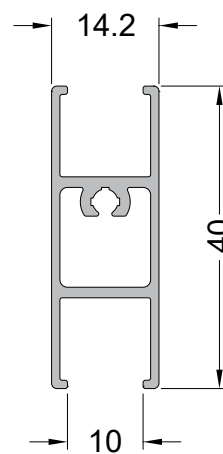

VG-615

0,646 Kg/m

Travessa inferior

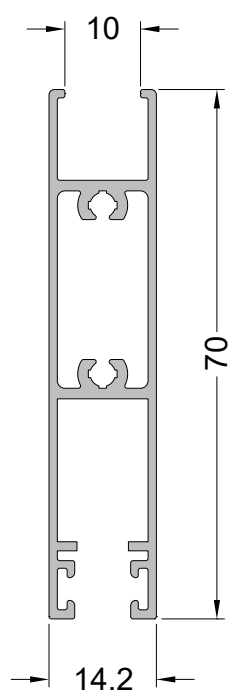

VG-710  
0,328 Kg/m  
Folha lateral

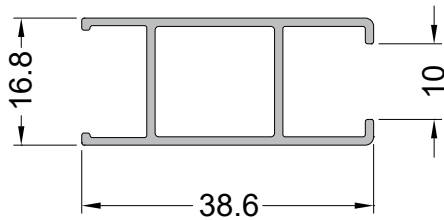

VG-711  
0,341 Kg/m  
Folha lateral

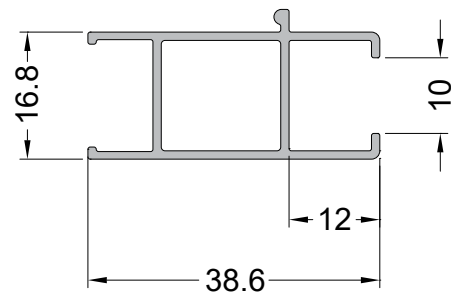

VG-745  
0,496 Kg/m  
Folha lateral

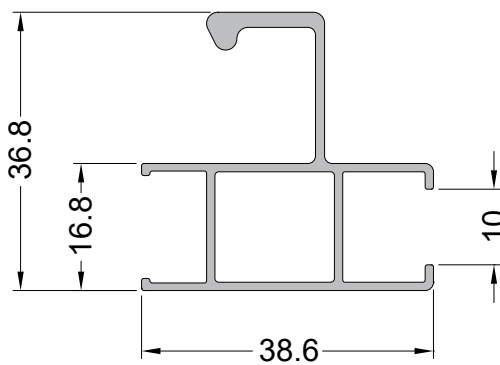

VG-731  
0,338 Kg/m  
Folha mão de amigo

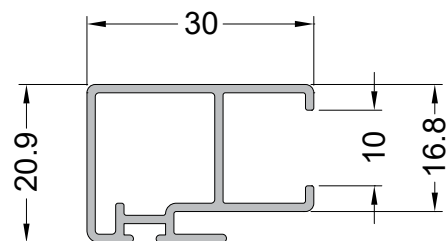

VG-830

0,400 Kg/m

Folha mão de amigo

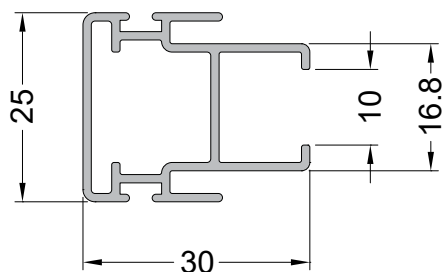

VG-736

0,707 Kg/m

Folha mão de amigo

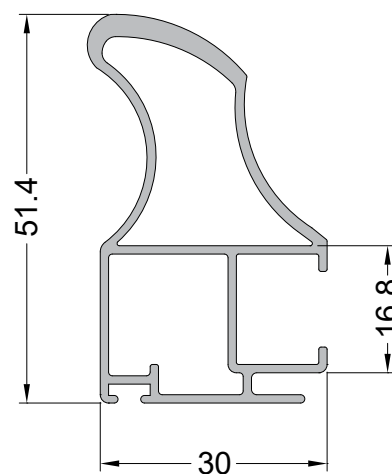

VG-737

0,815 Kg/m

Folha mão de amigo

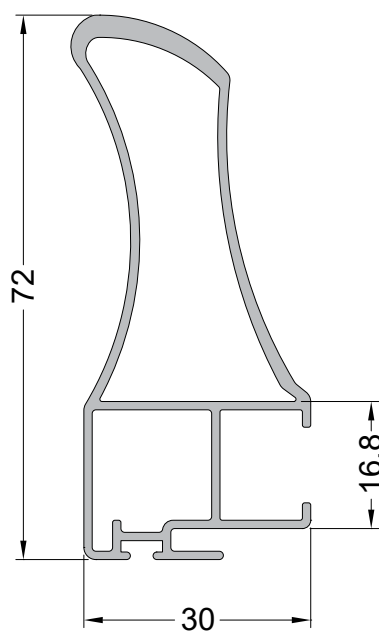

VG-732

0,609 Kg/m

Folha mão de amigo

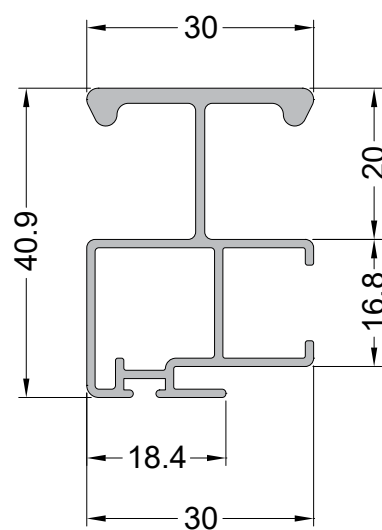

ALG-942  
0,292 Kg/m  
Marco Perimetral

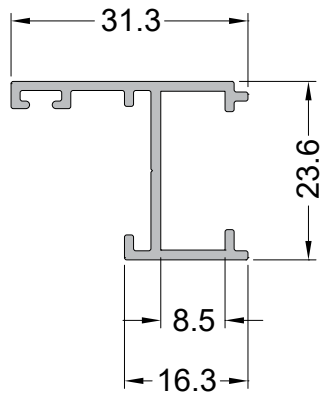

VG-030  
0,438 Kg/m  
Marco Perimetral

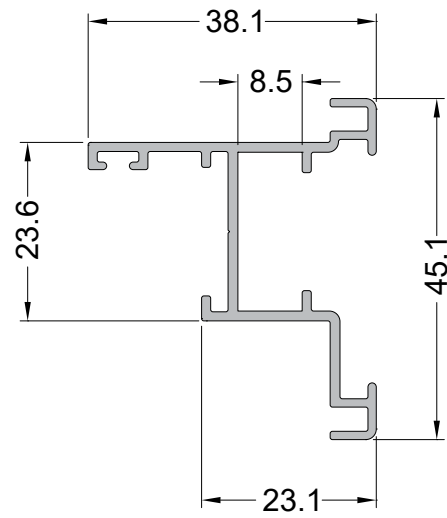

ALG-936  
0,525 Kg/m  
Travessa

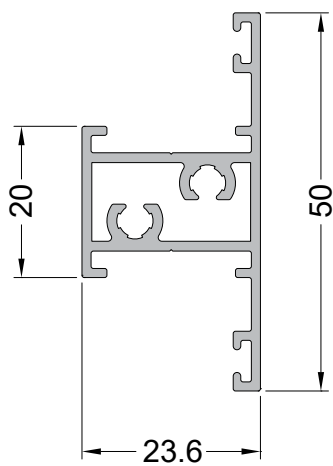

ALG-898  
0,520 Kg/m  
Coluna

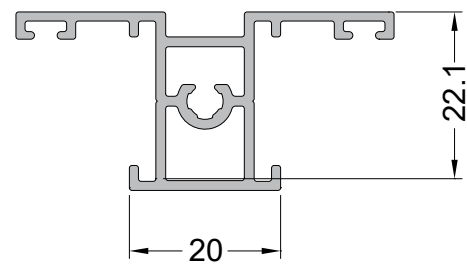

ALG-944  
0,354 Kg/m  
Folha

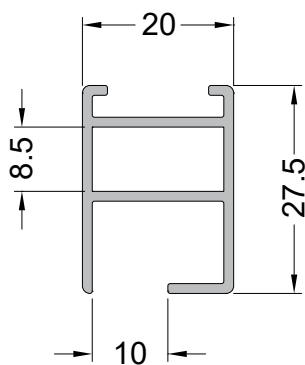

ALG-897  
0,342 Kg/m  
Folha

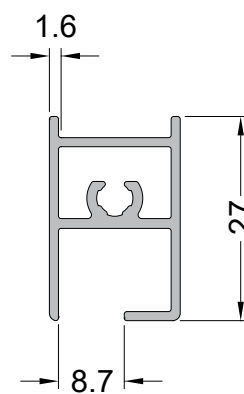

ALG-945  
0,401 Kg/m  
Folha

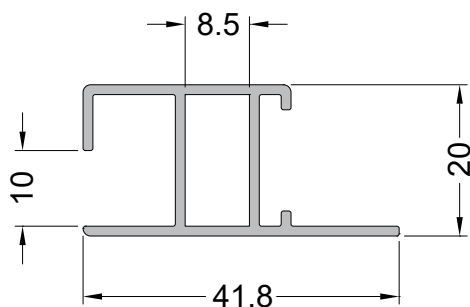

ALG-943  
0,143 Kg/m  
Pingadeira

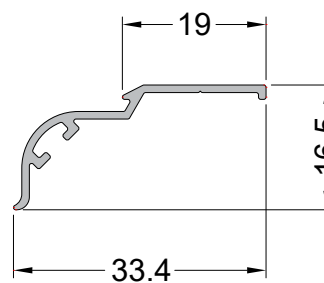

ALG-962  
0,528 Kg/m  
Marco

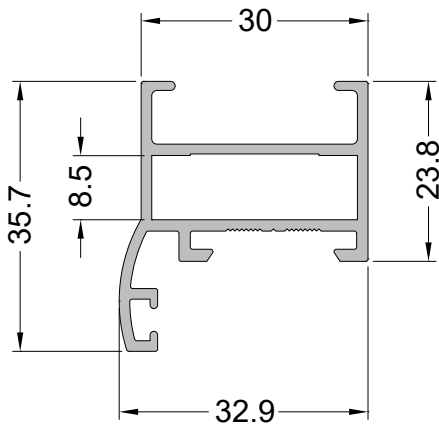

VG-150  
0,610 Kg/m  
Marco

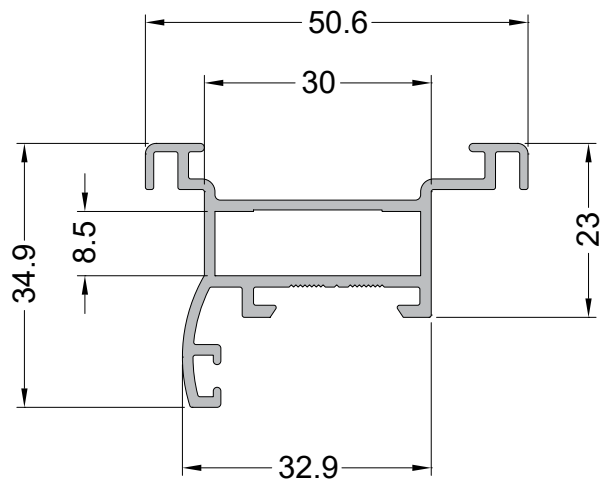

ALG-967  
0,589 Kg/m  
Folha

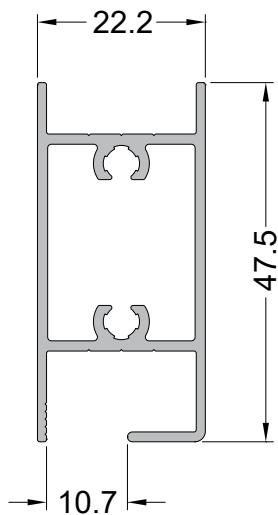

ALG-966  
0,650 Kg/m  
Travessa

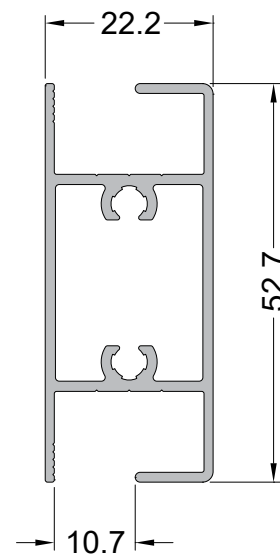



ALG-965  
1,020 Kg/m  
Travessa inferior

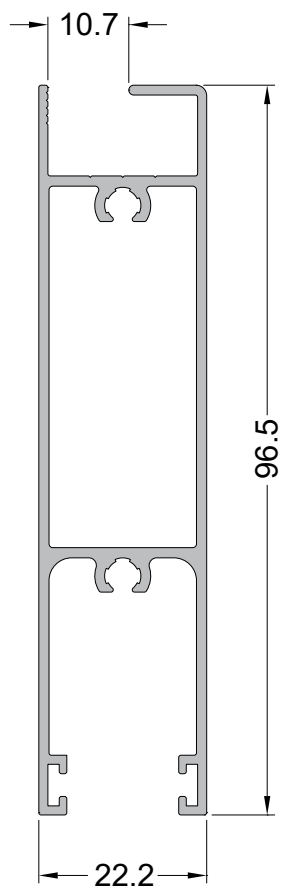

ALG-963  
0,615 Kg/m  
Folha

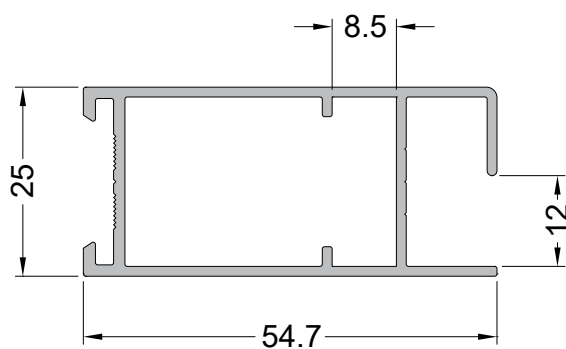

ALG-964  
0,276 Kg/m  
Mata-Junta

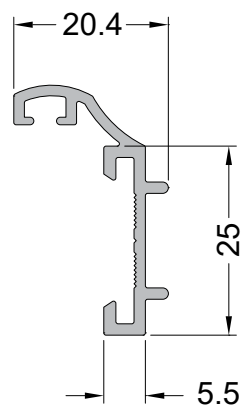

ALG-968  
0,203 Kg/m  
Folha

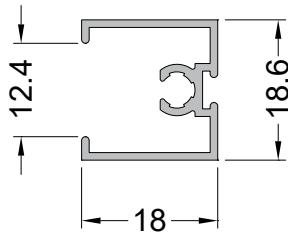

VG-040  
0,287 Kg/m  
Marco

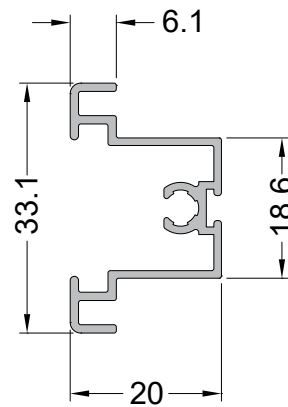

VG-041  
0,260 Kg/m  
Marco

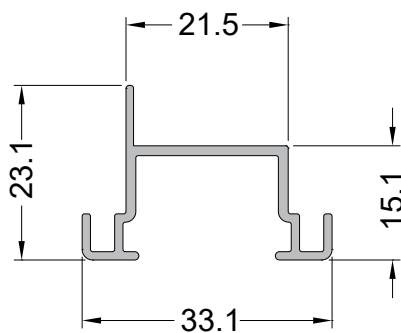

ALG-970  
0,252 Kg/m  
Travessa

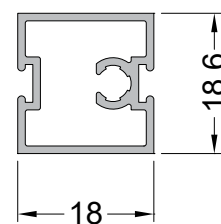

ALG-971  
0,204 Kg/m  
Folha

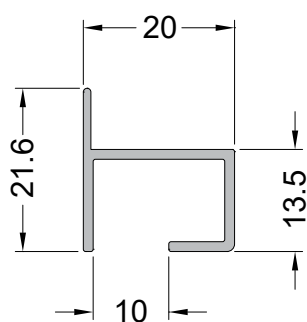

ALG-972  
0,225 Kg/m  
Folha

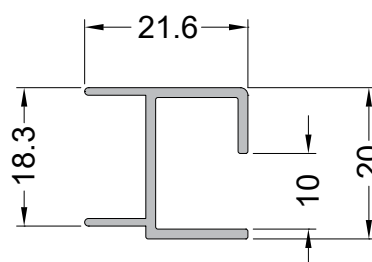

ALG-969  
0,196 Kg/m  
Folha

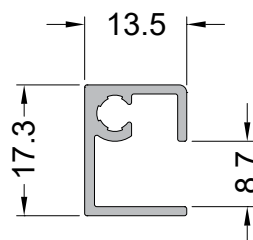

ALG-899  
0,251 Kg/m  
Folha

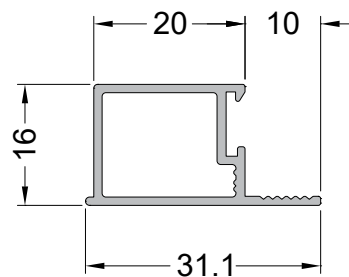

ALG-995  
0,520 Kg/m  
Veneziana

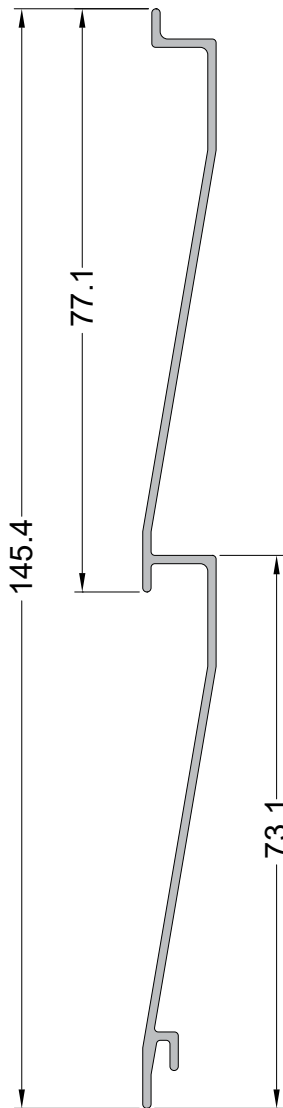

ALG-992  
0,280 Kg/m  
Veneziana

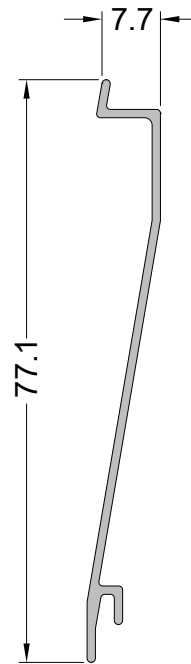

ALG-941  
0,132 Kg/m  
Baguete

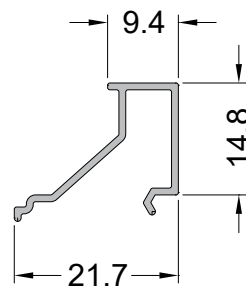

VG-950

0,149 Kg/m

Complemento - porta

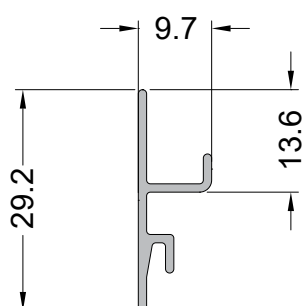

VG-951

0,137 Kg/m

Complemento - janela

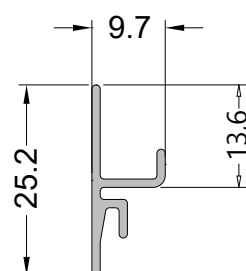

E-566 (ALG-00126)

0,760 Kg/m

Marco Superior

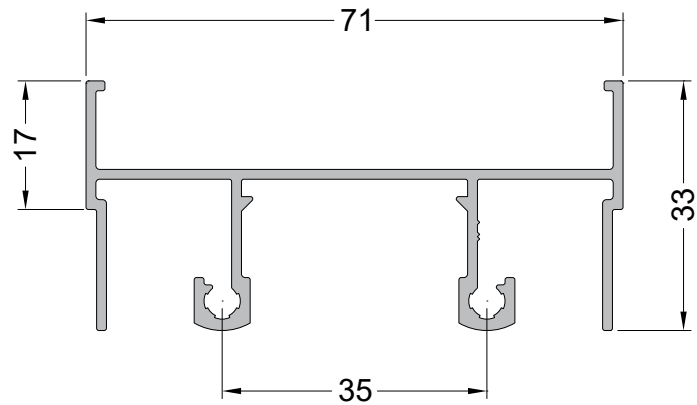

E-565 (ALG-00226)

0,700 Kg/m

Marco Inferior

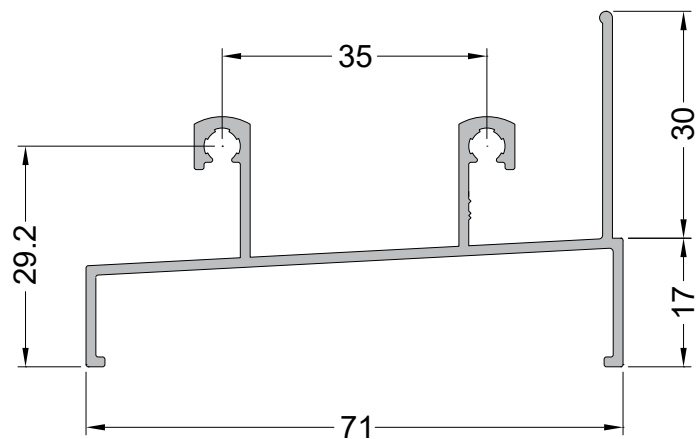

Y-777 (ALG-00426)

0,475 Kg/m

Marco Travessa

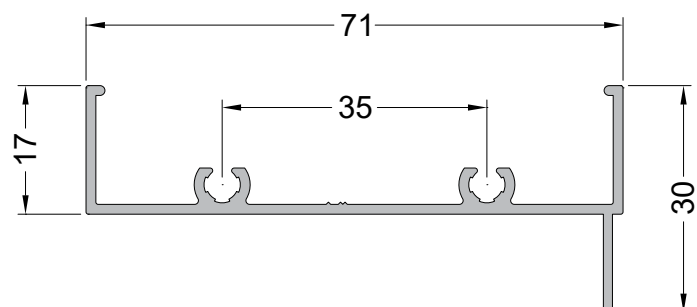

P-634 (ALG-00526)

0,950 Kg/m

Travessa Bandeira

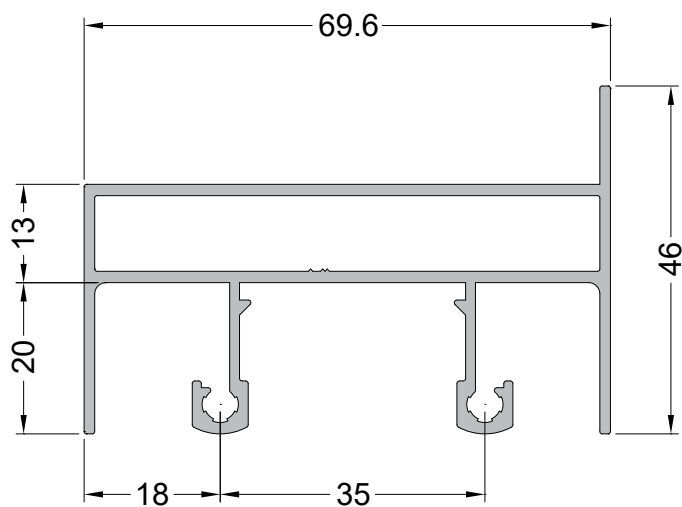

CX-3036

1,022 Kg/m

Marco Intermediário  
Peitoril

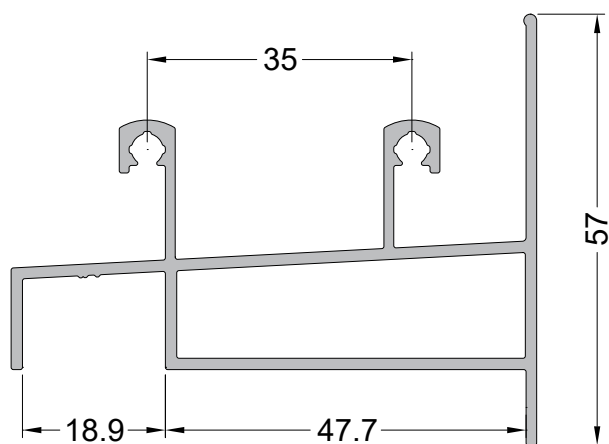

CX-320 (ALG-22826)

0,667 Kg/m

Marco Inferior

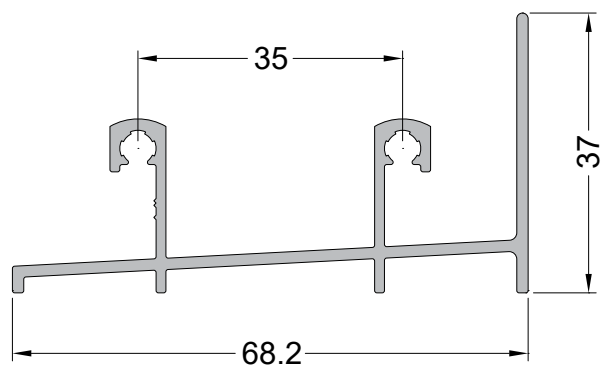

E-578

0,704 Kg/m

Marco Inferior

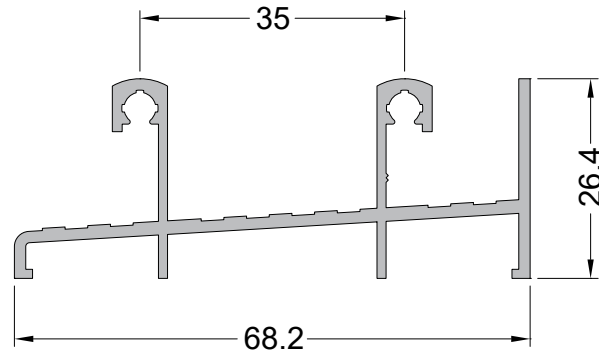

P-636 (ALG-00926)

0,907 Kg/m

Coluna

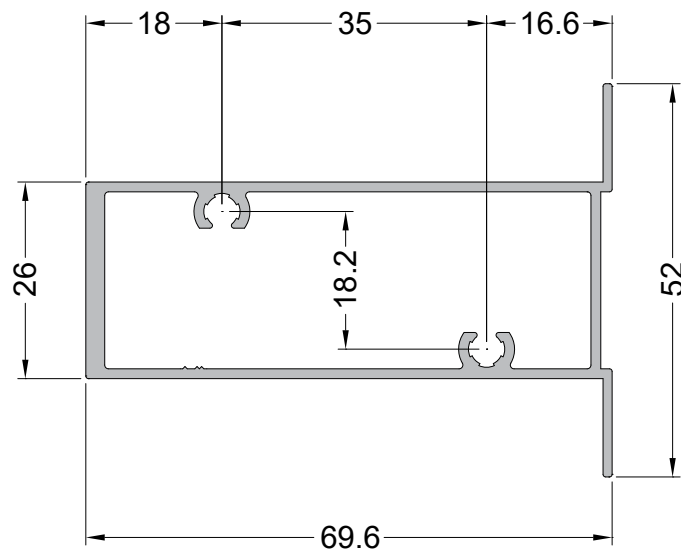



E-567 (ALG-00326)

0,508 Kg/m

Marco Lateral

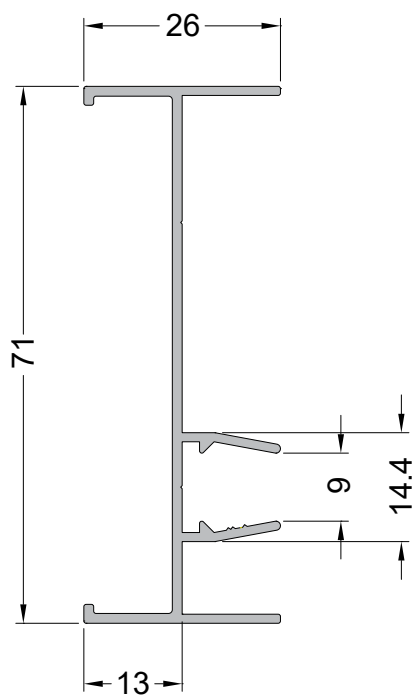

Y-776 (ALG-00726)

0,357 Kg/m

Marco Lateral

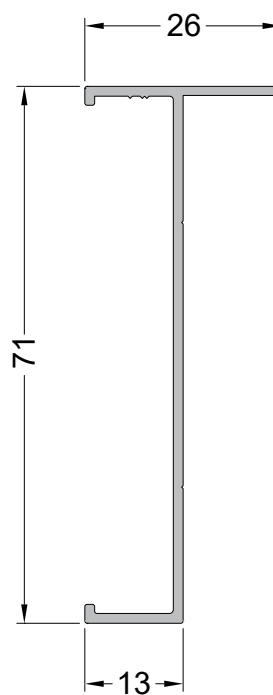

E-568 (ALG-00826)

0,245 Kg/m

Mata-Junta

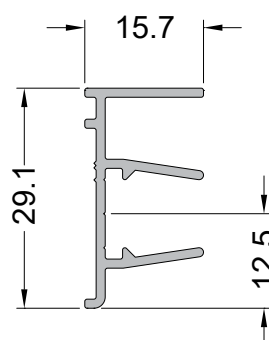

ALG-29126

0,263 Kg/m

Mata-Junta

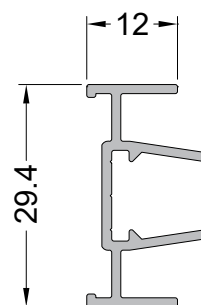

E-602 (ALG-02626)

0,875 Kg/m

Marco Superior

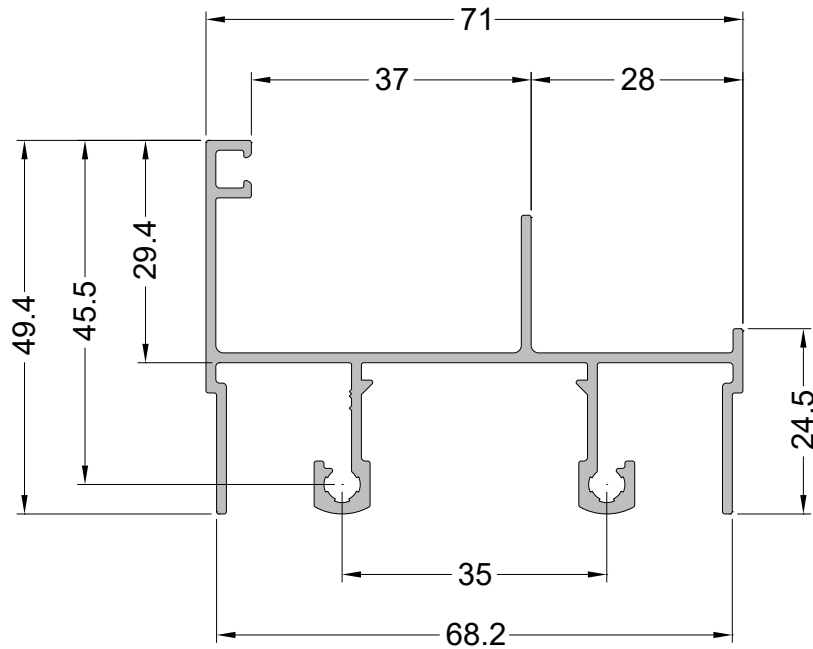

E-601 (ALG-02726)

0,823 Kg/m

Marco Inferior

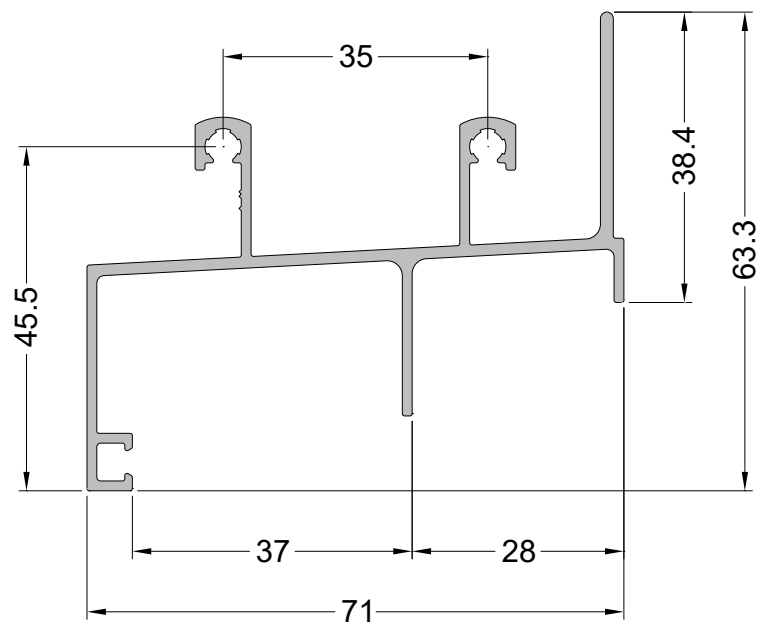

Z-283 (ALG-02926)

0,645 Kg/m

Marco Travessa

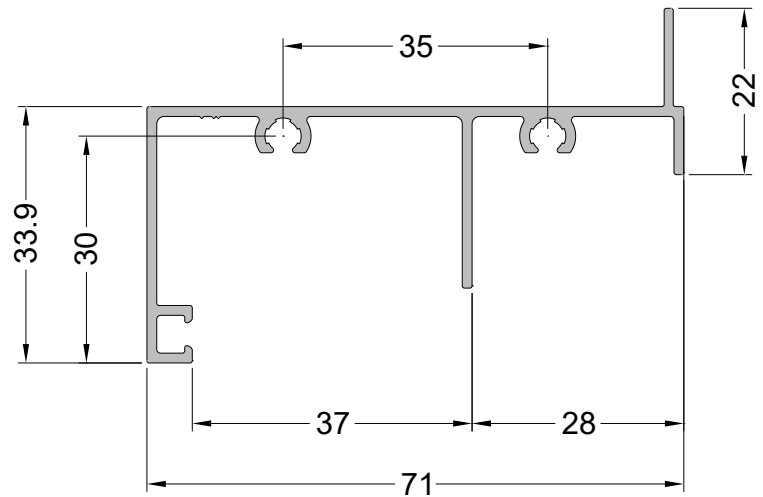

Z-281 (ALG-02826)

0,517 Kg/m

Marco Lateral

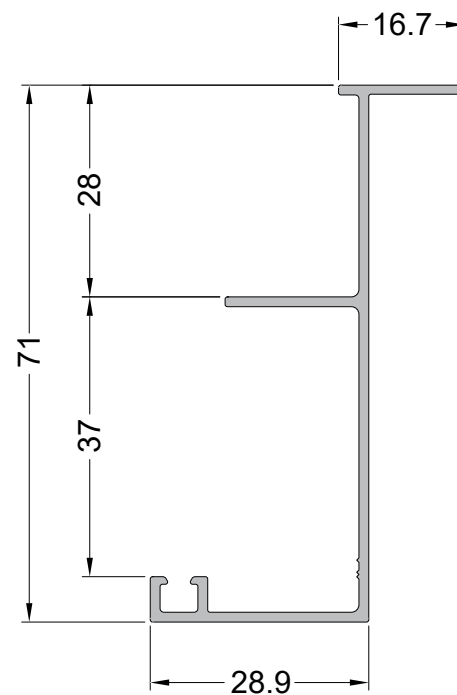

E-571 (ALG-01026)

1,024 Kg/m

Marco Superior

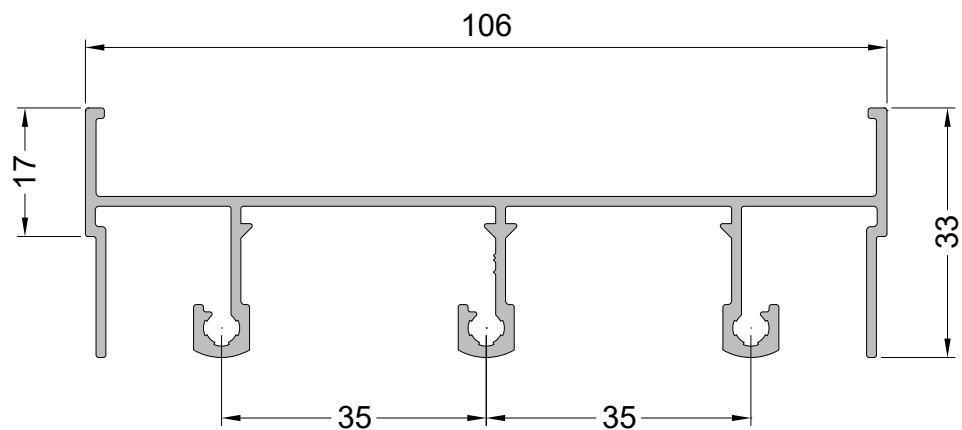

E-572 (ALG-01126)

0,941 Kg/m

Marco Inferior

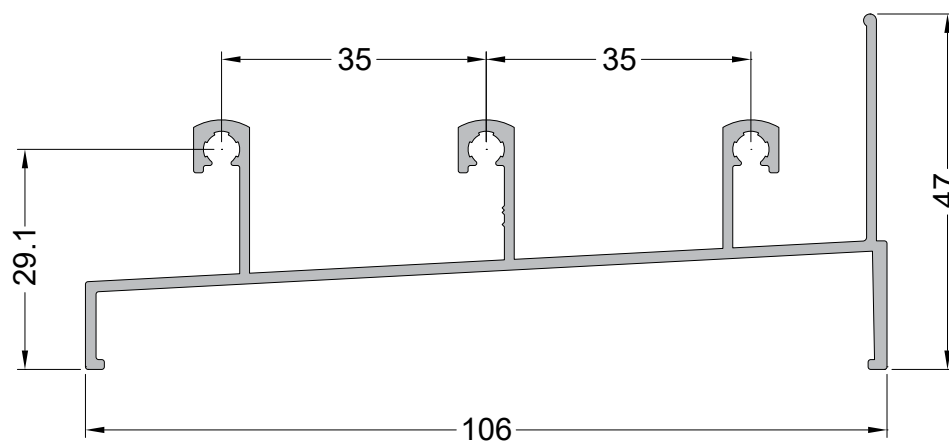

ALG-23026

0,954 Kg/m

Marco Inferior

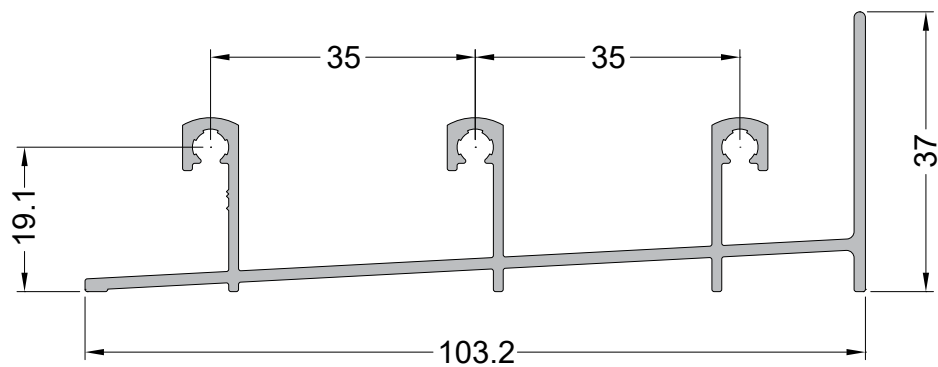

Y-784 (ALG-01826)

0,658 Kg/m

Marco Travessa

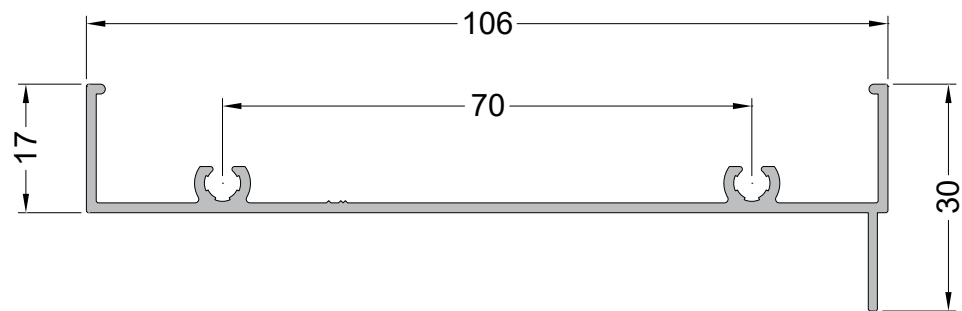

ALG-23126

0,807 Kg/m

Marco Inferior

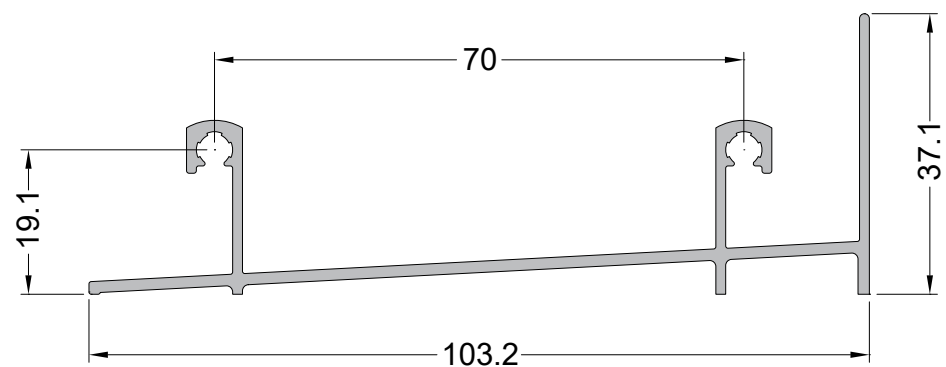

P-661 (ALG-01926)

1,748 Kg/m

Travessa Bandeira

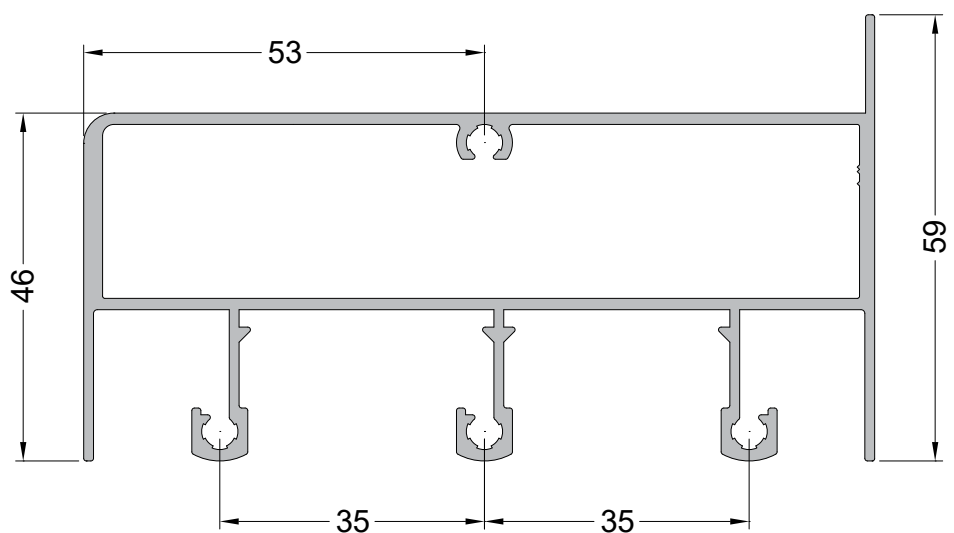

**Y-778 (ALG-01226)**

0,508 Kg/m

Marco Lateral

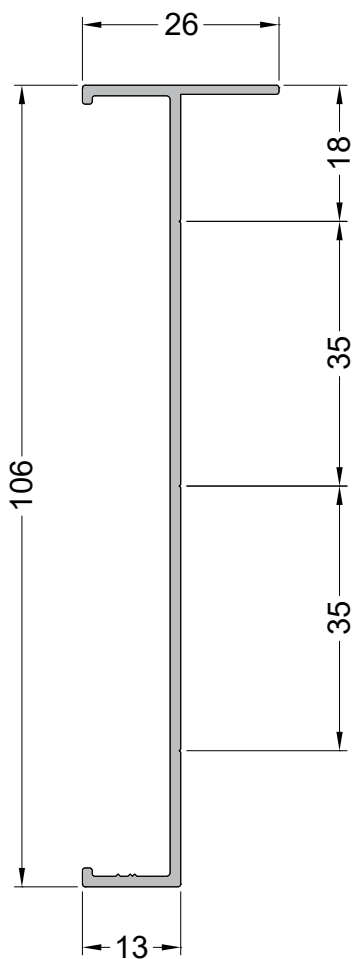

**E-574 (ALG-01426)**

0,674 Kg/m

Marco Lateral

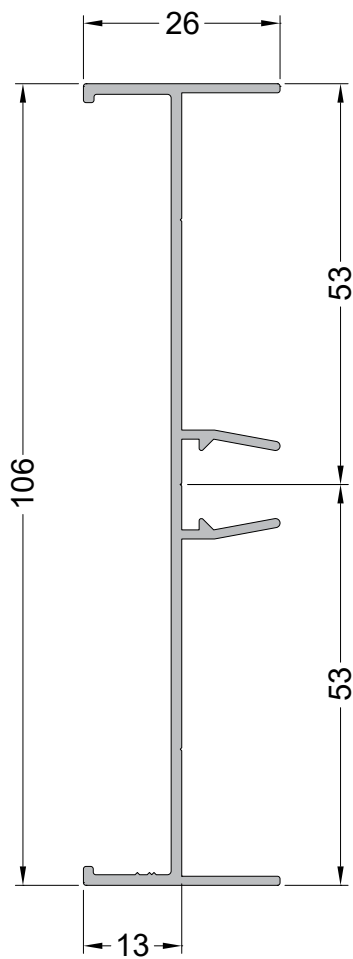

**E-573 (ALG-01326)**

0,698 Kg/m

Marco Lateral

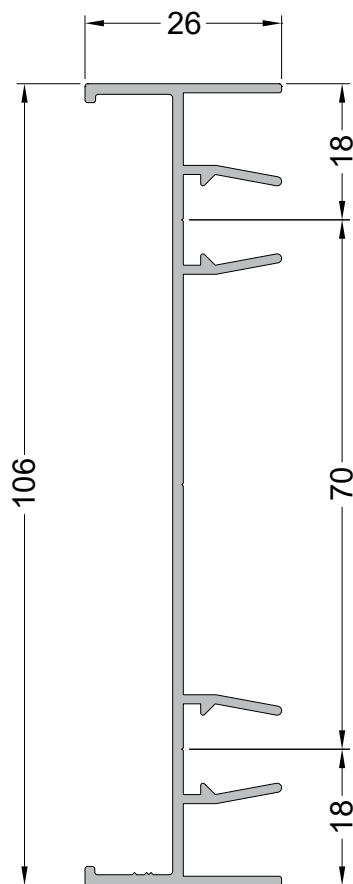

**CX-3089**

0,457 Kg/m

Marco Inferior

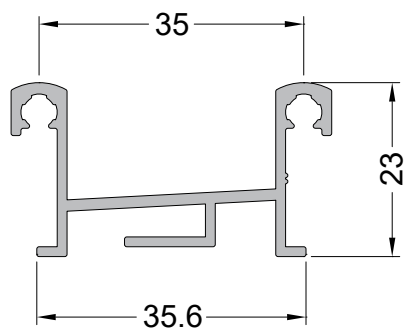

**ALG-27126**

0,347 Kg/m

Trilho / Correr

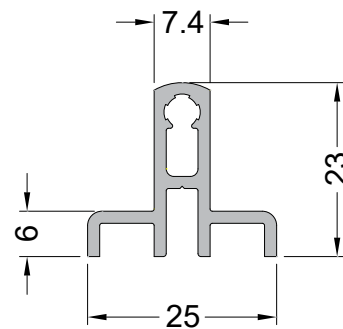

E-604 (ALG-03126)

1.279 Kg/m

Marco Superior

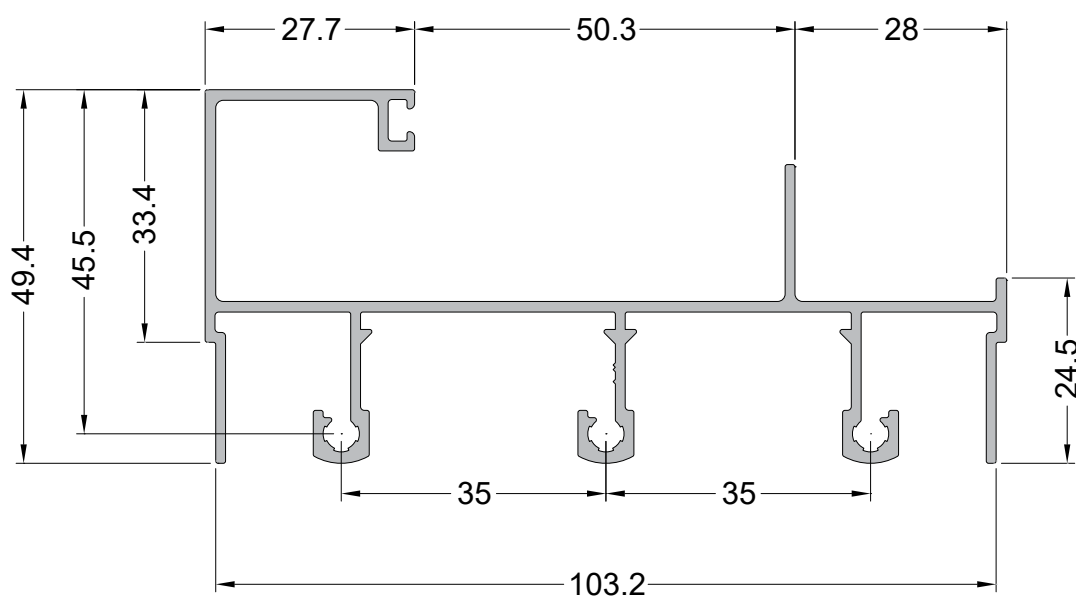

E-603 (ALG-03226)

1,195 Kg/m

Marco Inferior

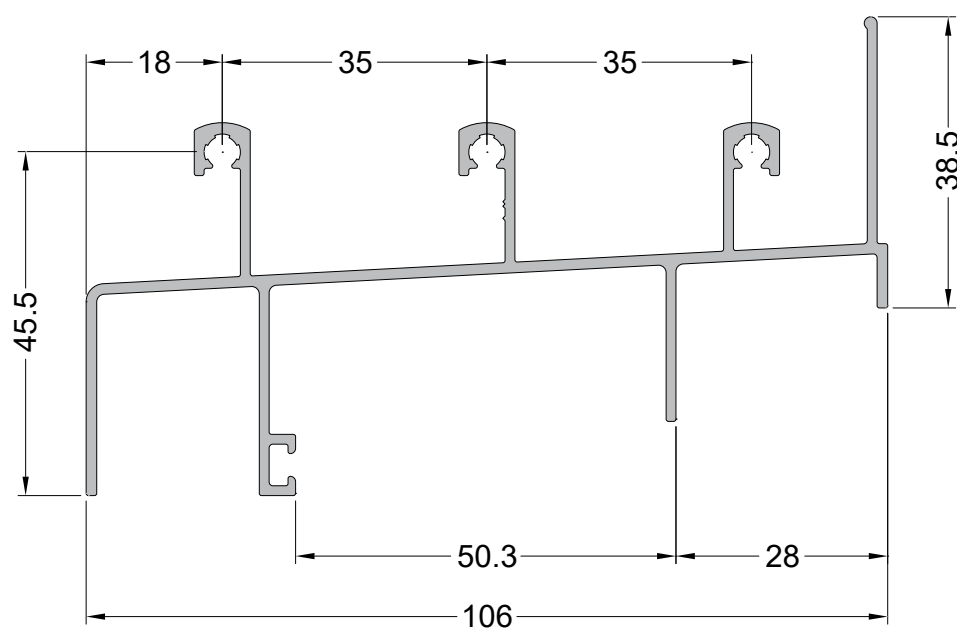

Z-282 (ALG-03326)

0,742 Kg/m

Marco Lateral

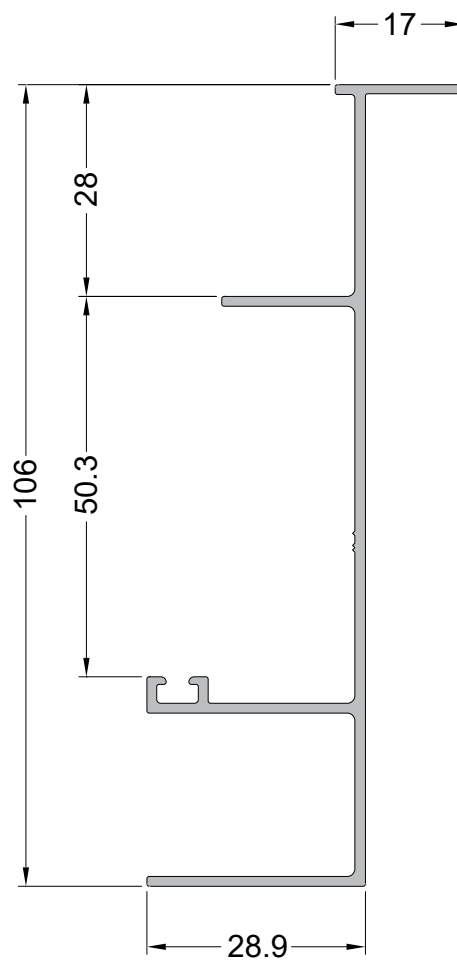



E-645 (ALG-12126)

1,569 Kg/m

Marco Superior

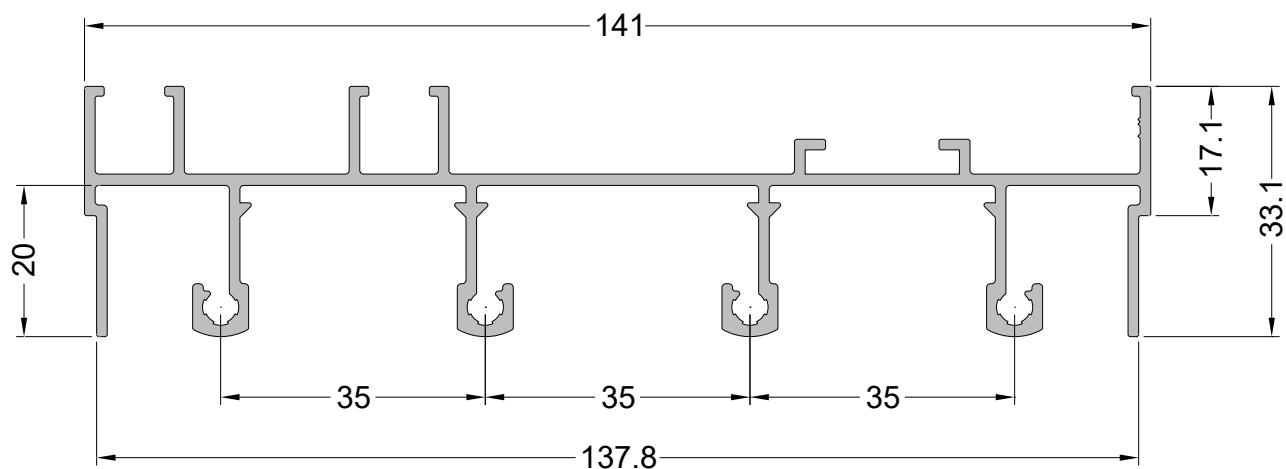

E-646 (ALG-12226)

1,509 Kg/m

Marco Inferior

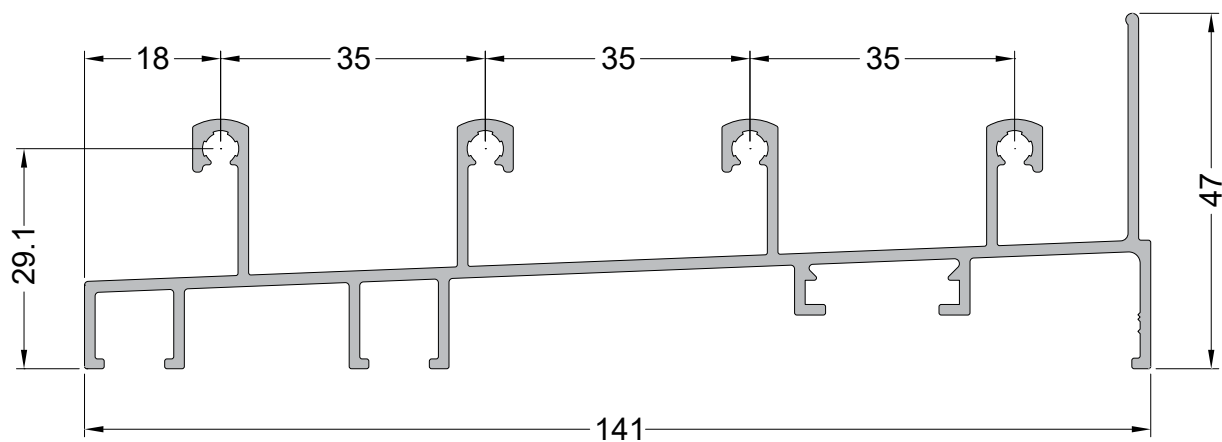

E-647 (ALG-12326)

0.921 Kg/m

Marco Lateral

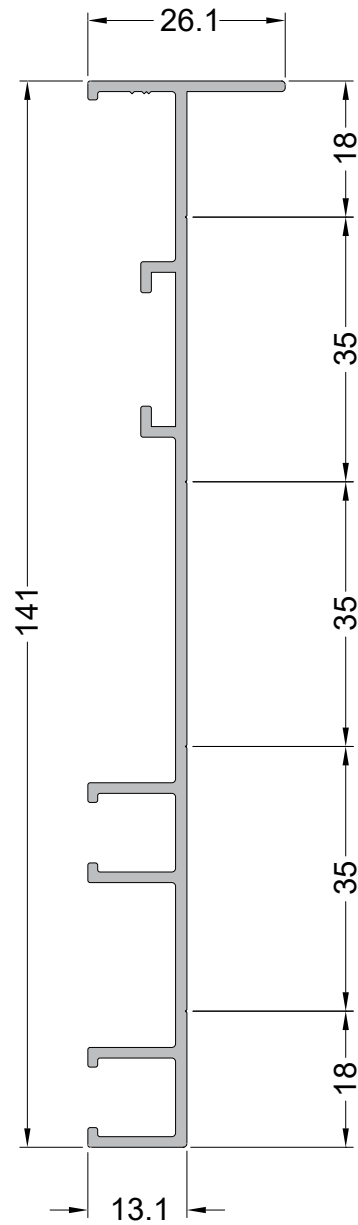

ALG-02426

1,023 Kg/m

Marco Superior

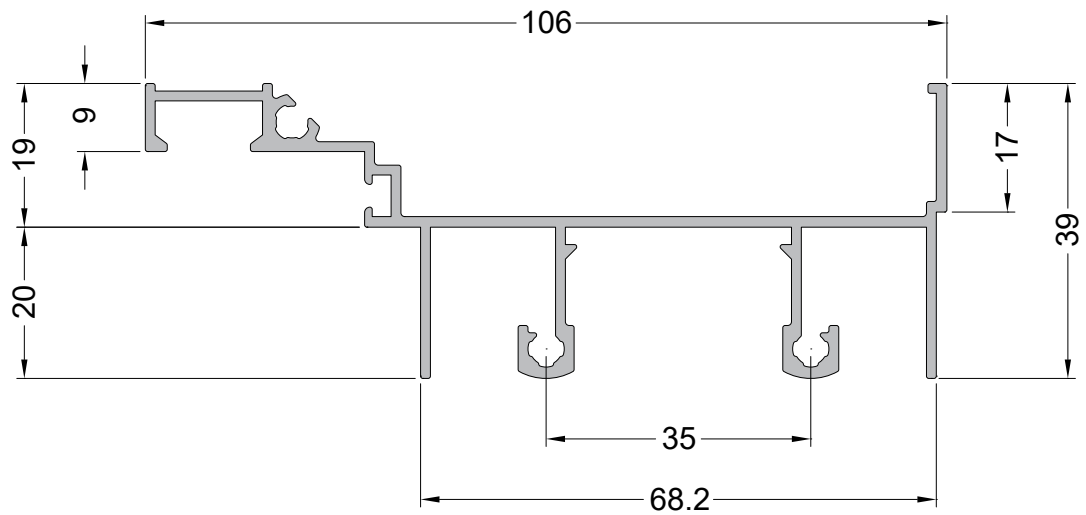

ALG-02526

0,973 Kg/m

Marco Inferior

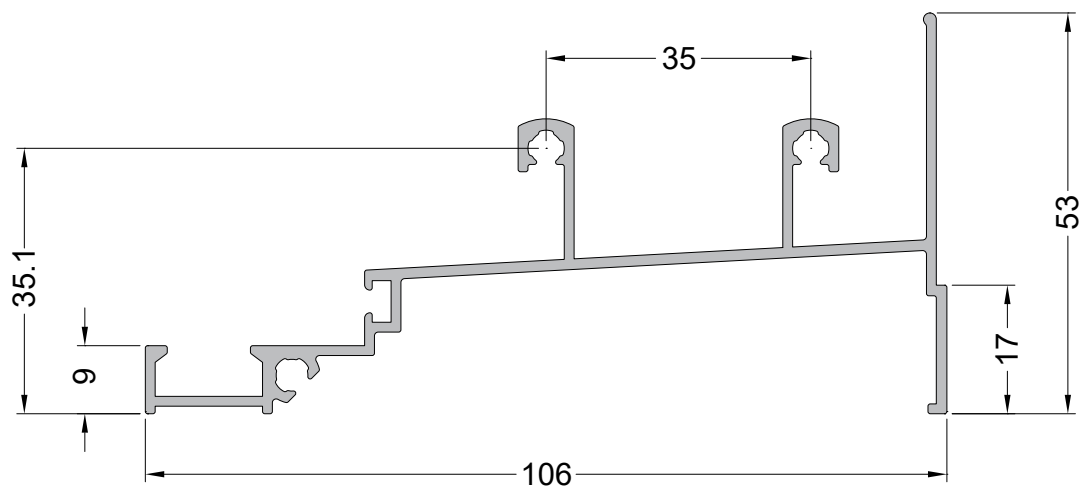

ALG-1001  
0,747 Kg/m  
Marco Superior

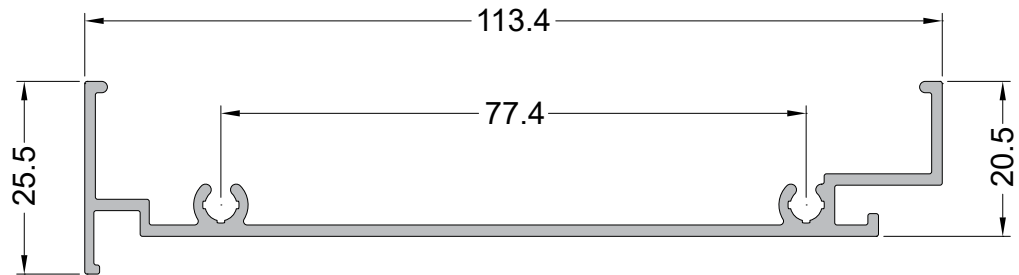

ALG-1002  
0,773 Kg/m  
Marco Intermediário

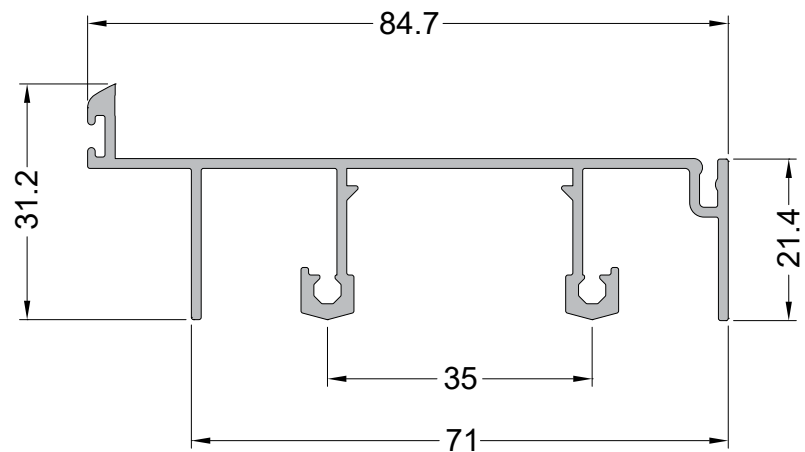

ALG-1043  
1,159 Kg/m  
Marco Intermediário  
Reforçado

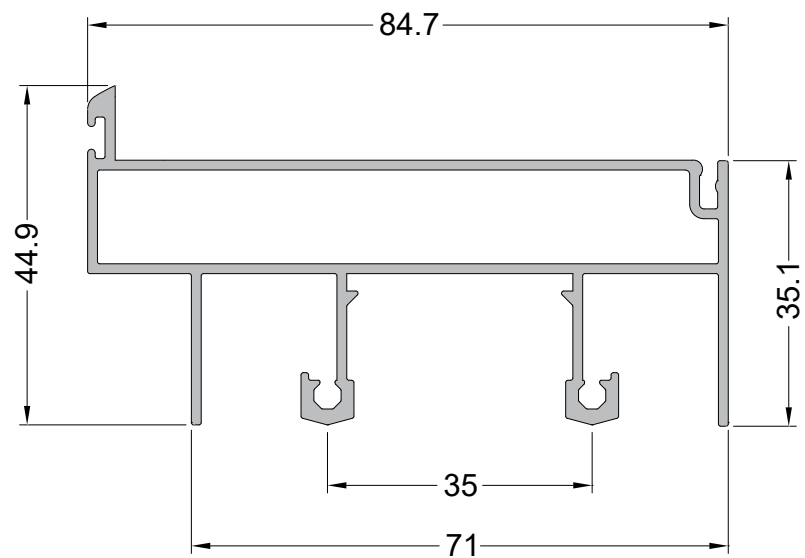

ALG-1003  
0,993 Kg/m  
Marco Inferior

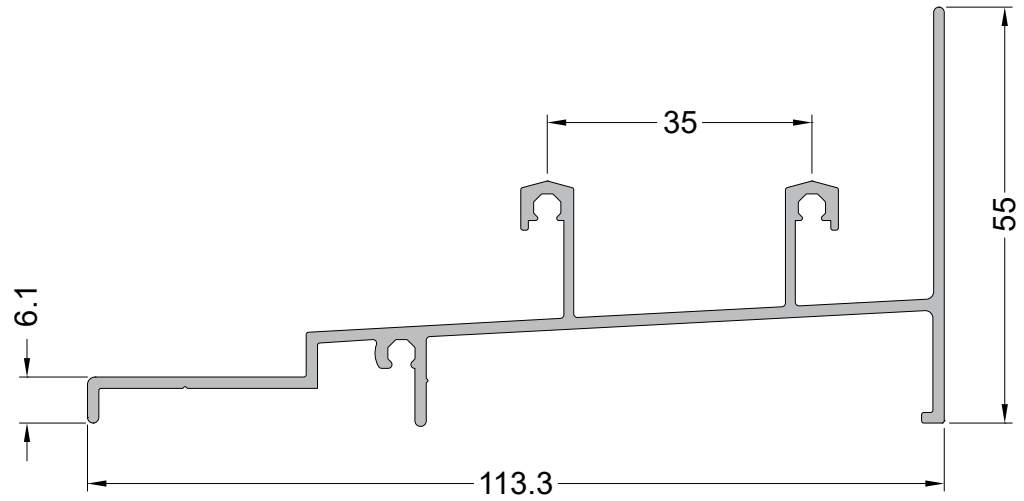

ALG-1000  
0,573 Kg/m  
Marco

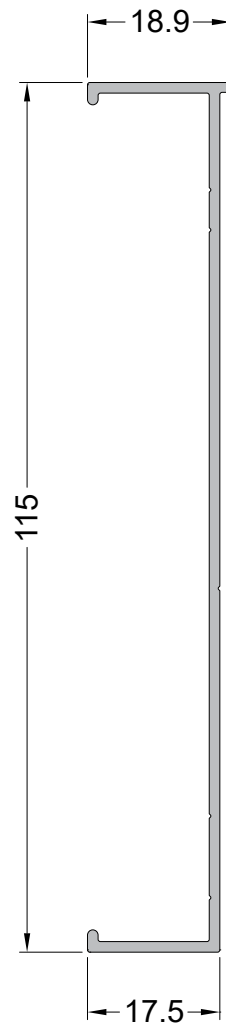

ALG-1041  
0,949 Kg/m  
Tampa Interna

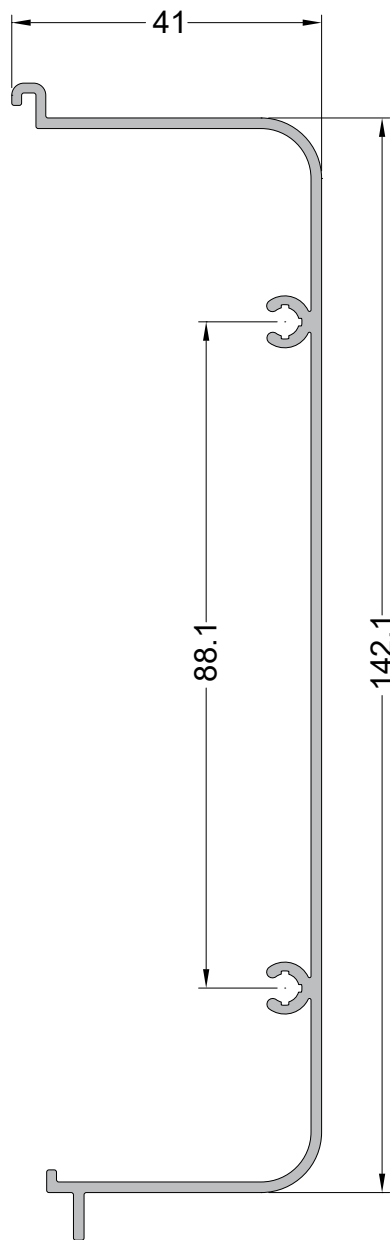

ALG-1006  
0,937 Kg/m  
Tampa Interna

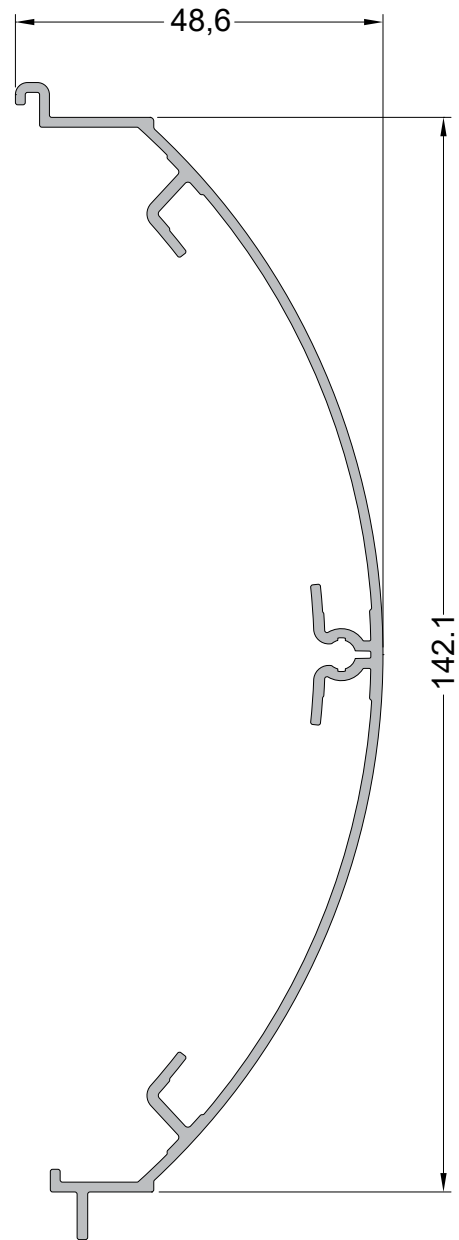

ALG-1051  
1,137 Kg/m  
Tampa Interna

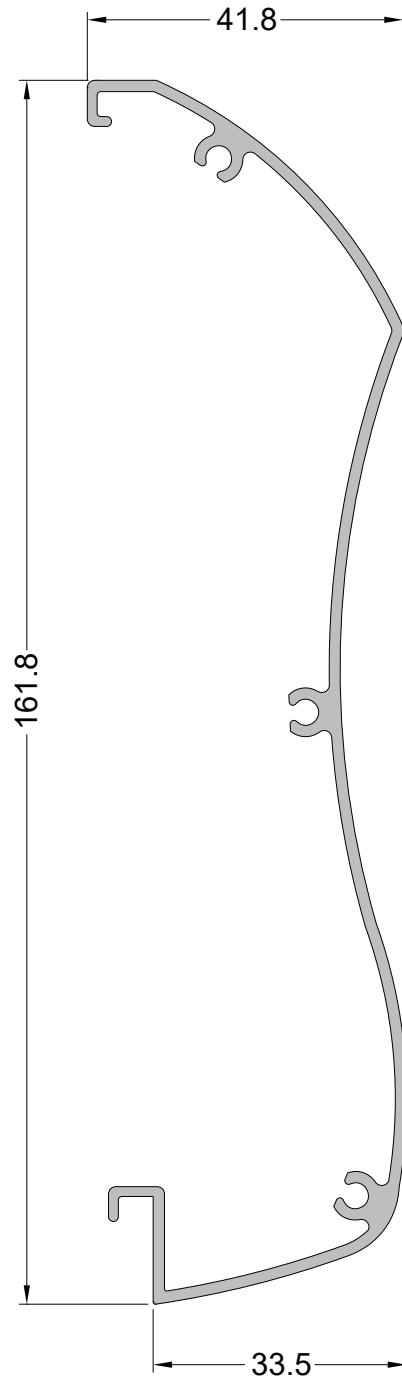

ALG-1042  
1,967 Kg/m  
Tampa Interna

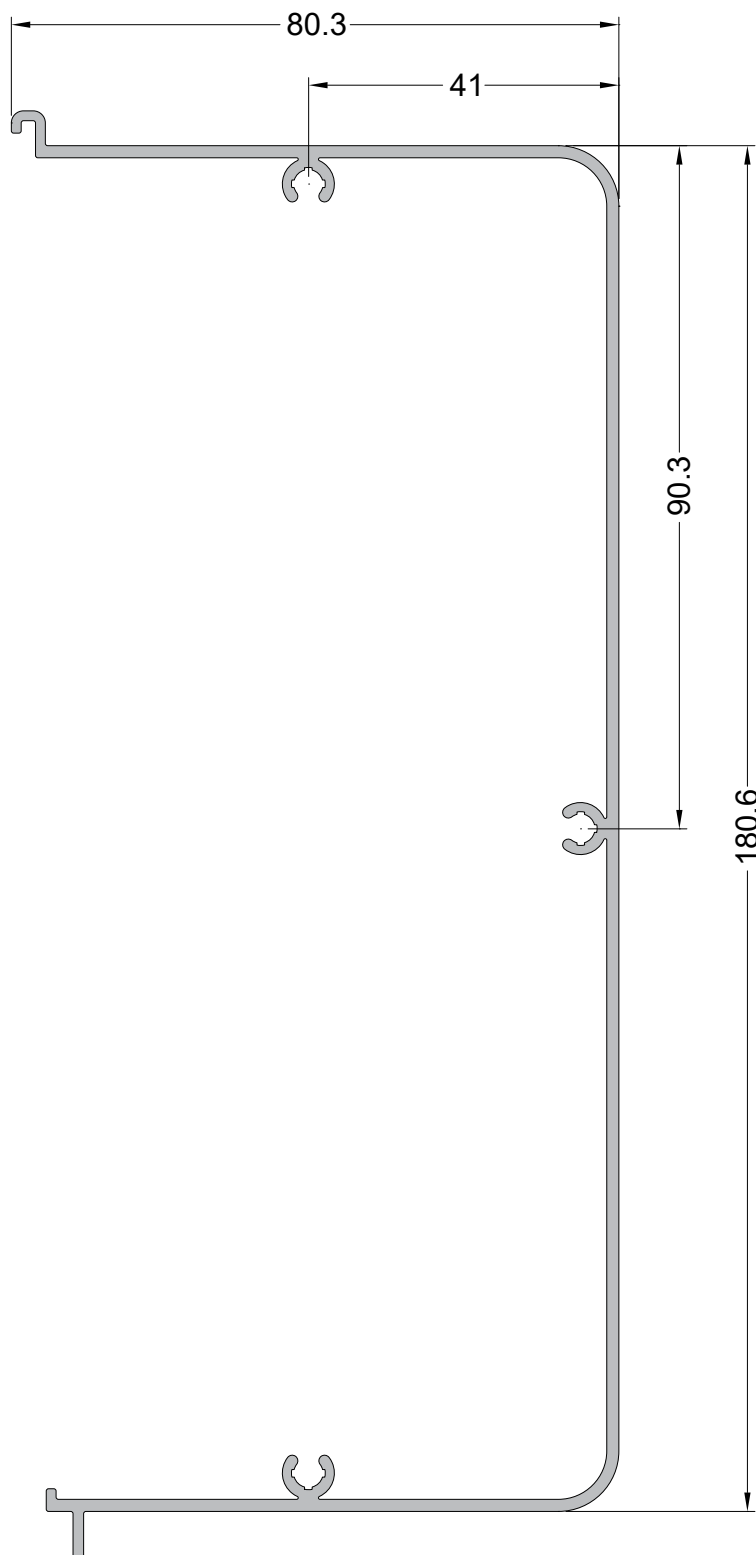



ALG-1009  
1,260 Kg/m  
Tampa Interna

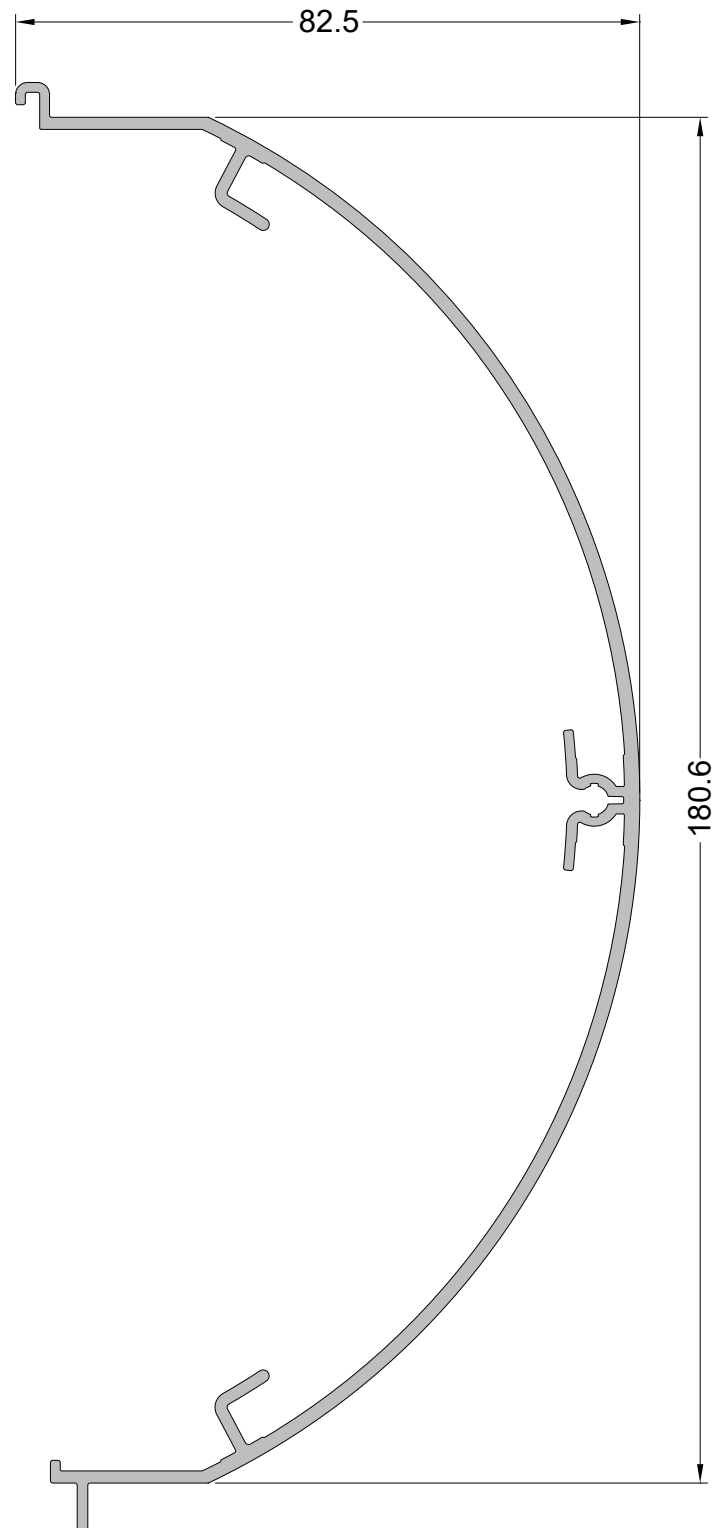

ALG-1052  
1,388 Kg/m  
Tampa Interna

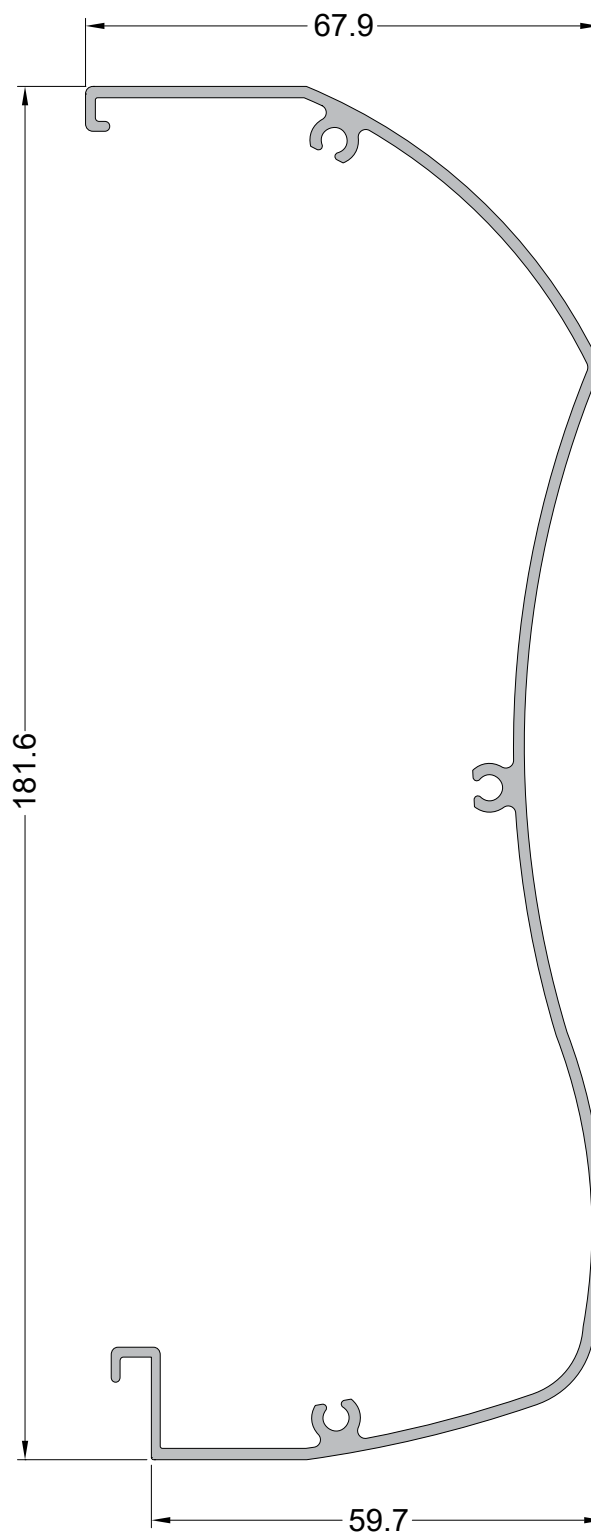

ALG-1007  
0,867 Kg/m  
Tampa Externa

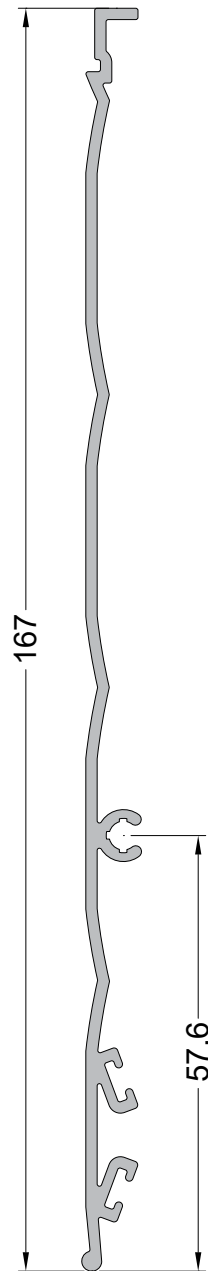

ALG-1010  
1,080 Kg/m  
Tampa Externa

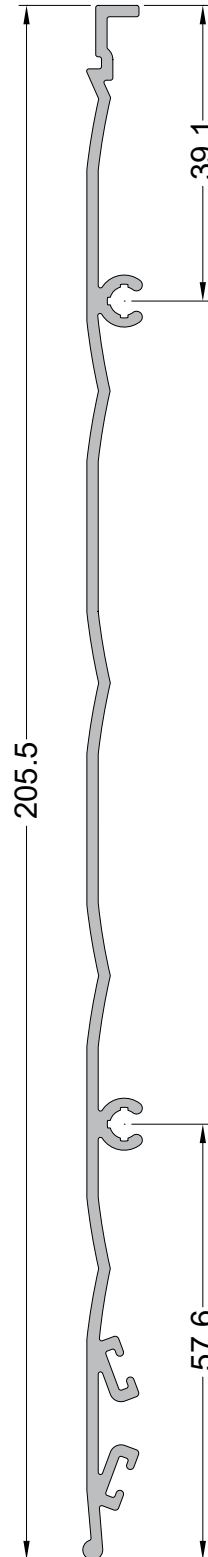

MN-001

1.377 Kg/m

Marco Superior

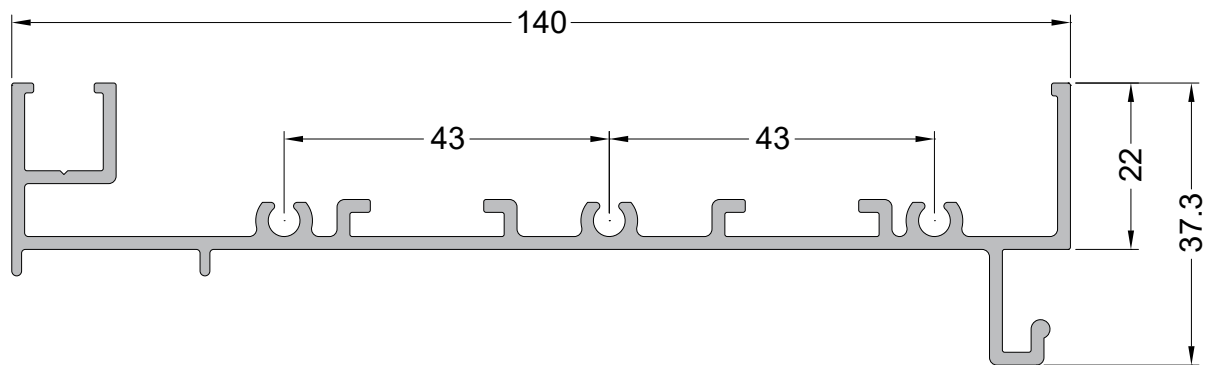

MN-023

0.688 Kg/m

Marco Intermediário

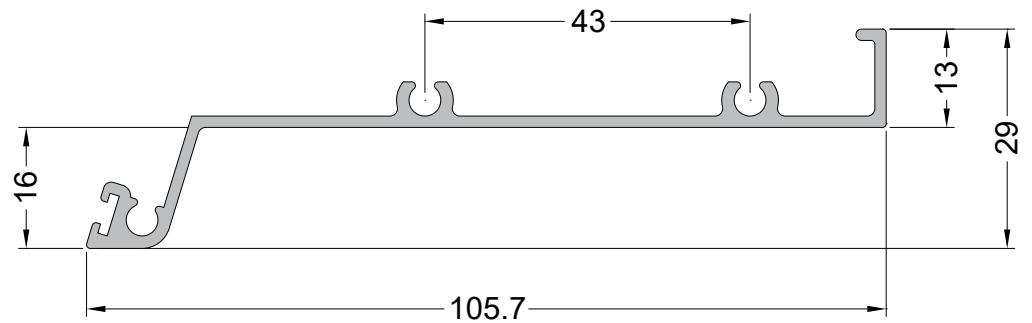

ALG-200

0,623 Kg/m

Marco Intermediário

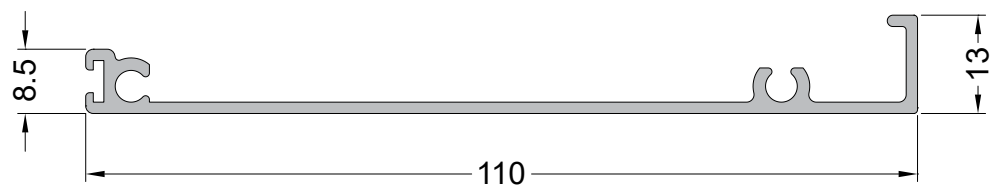

ALG-940 (MN-049)

1.312 Kg/m

Marco Intermediário

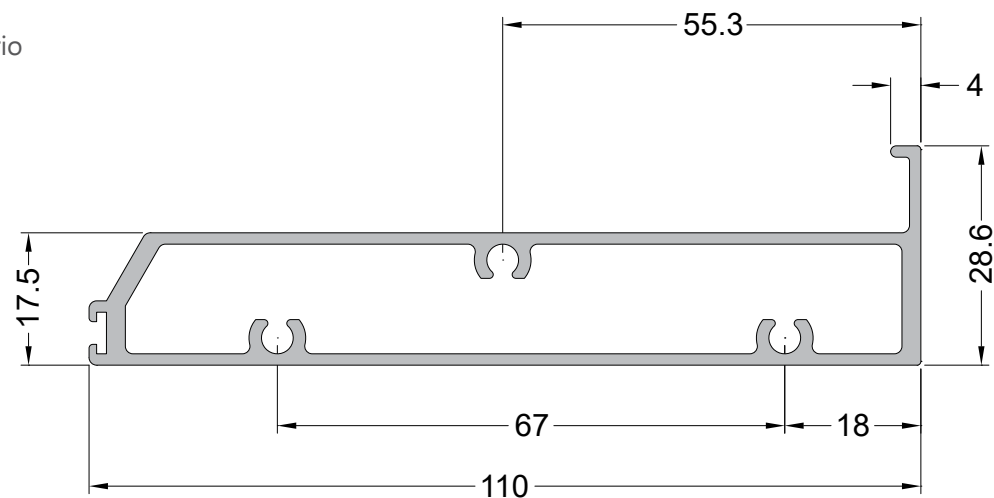

MN-010

1.495 Kg/m

Marco Inferior

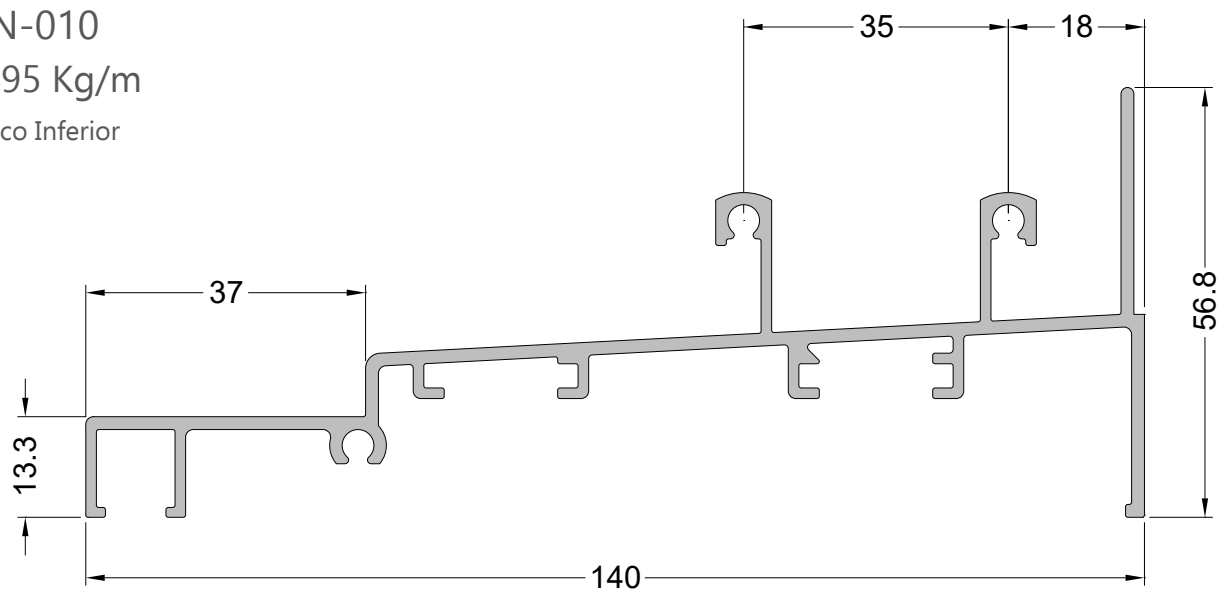

MN-003

1.091 Kg/m

Marco

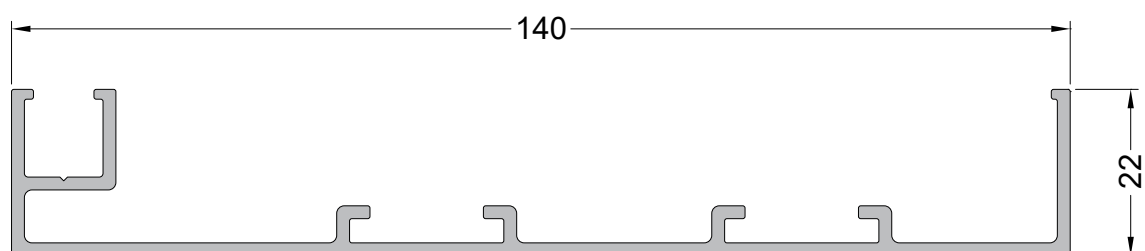

ALG-930  
1,340 Kg/m  
Tampa Externa

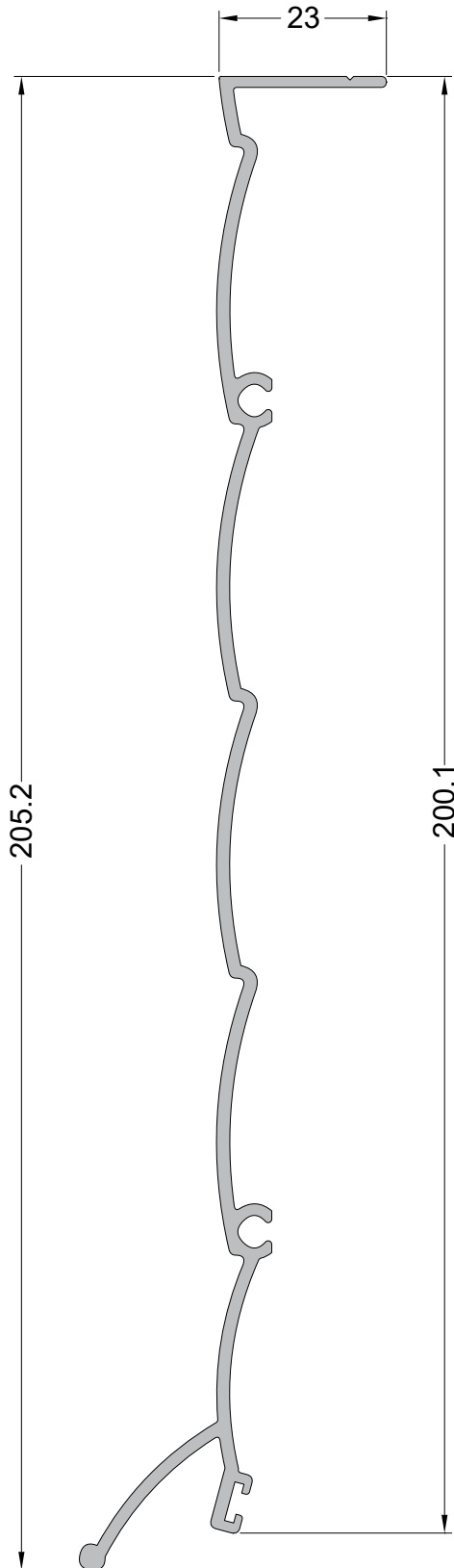

ALG-130  
1,463 Kg/m  
Tampa Interna

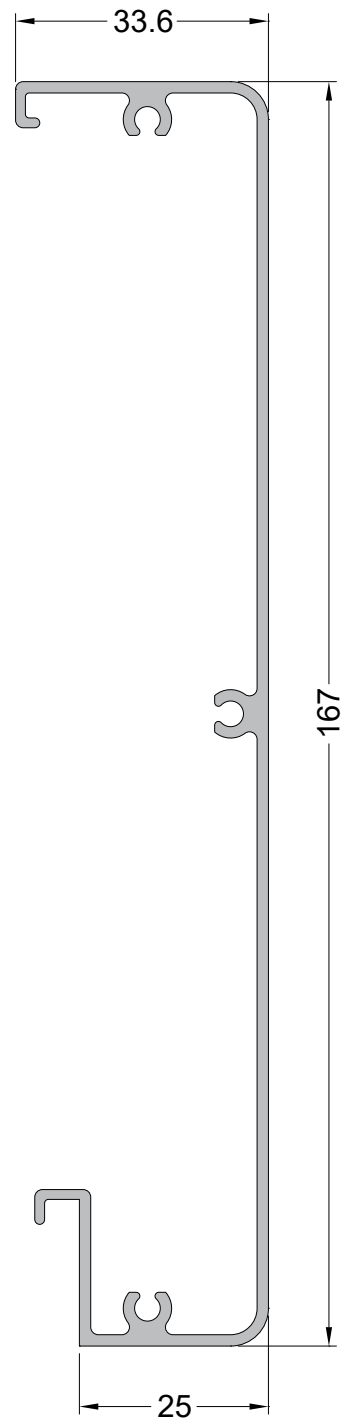

ALG-1004  
0,906 Kg/m  
Marco Lateral

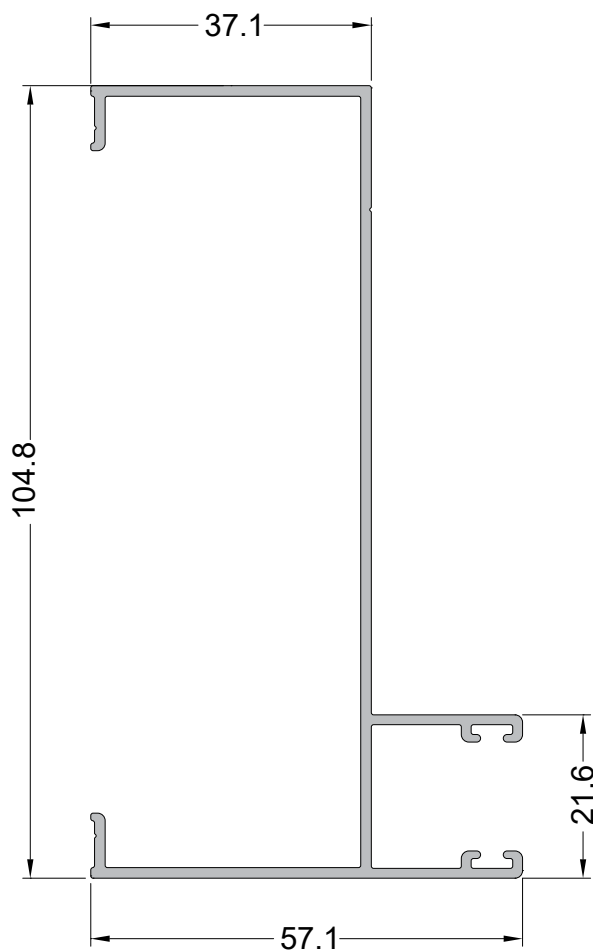

MN-007  
0.710 Kg/m  
Guia Persiana

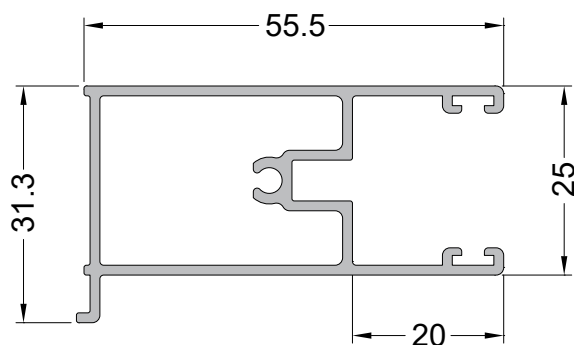

ALG-1005  
0,577 Kg/m  
Guia da Persiana

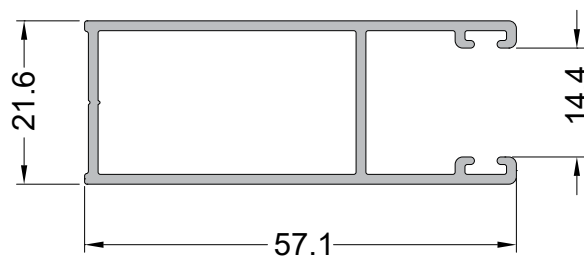

ALG-1008  
0,866 Kg/m  
Guia Central

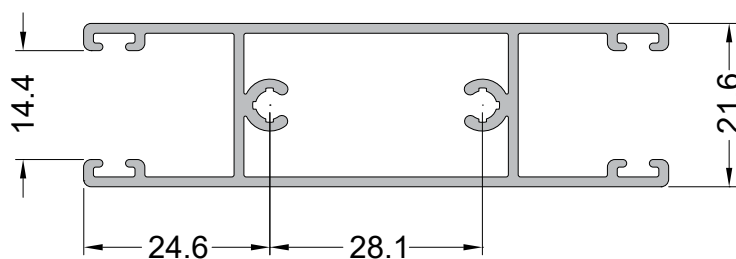

ALG-050

0,824 Kg/m

Caixa do Recolhedor

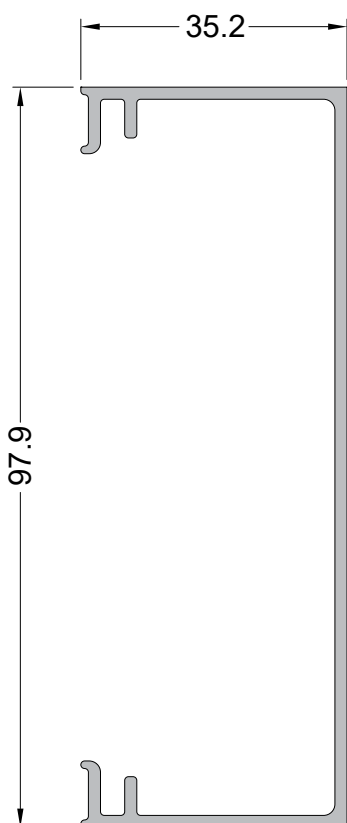

DS-238

0,485 Kg/m

Tubo Recolhedor

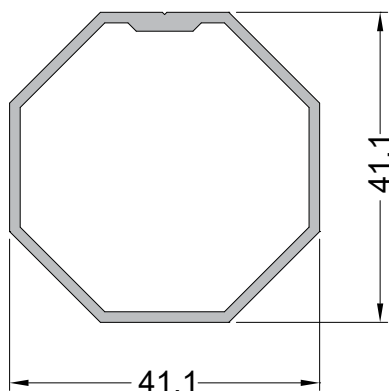

MN-015

0.843 Kg/m

Tubo Recolhedor

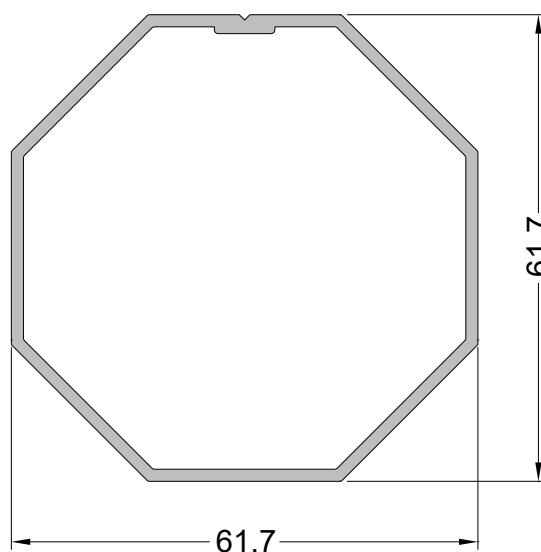

MN-055

0.376 Kg/m

Terminal

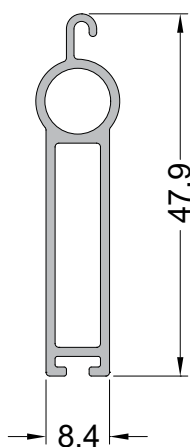

ALG-400

0,168 Kg/m

Complemento

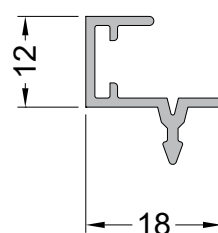



Y-829 (ALG-05326)

0,458 Kg/m

Travessa Folha

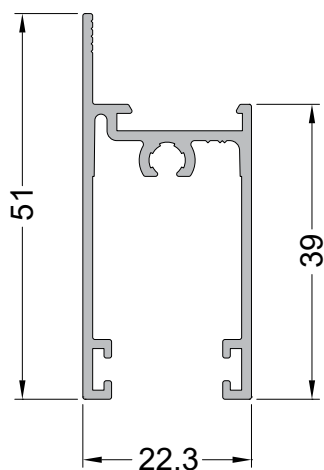

P-633 (ALG-22726)

0.549 Kg/m

Travessa Central Folha

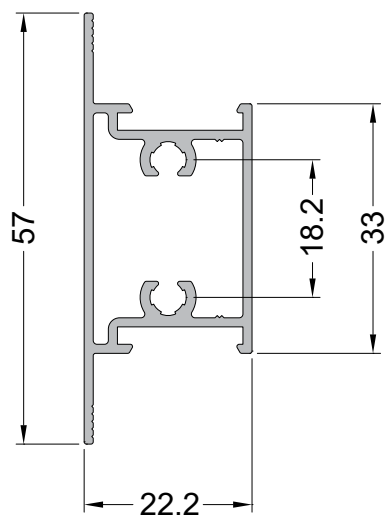

P-668 (ALG-05026)

0,870 Kg/m

Travessa Central Folha

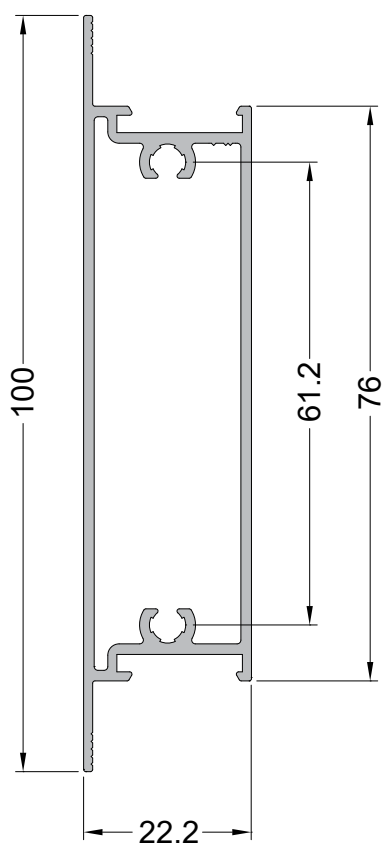

A-283 (ALG-22526)

0,987 Kg/m

Travessa Inferior Folha

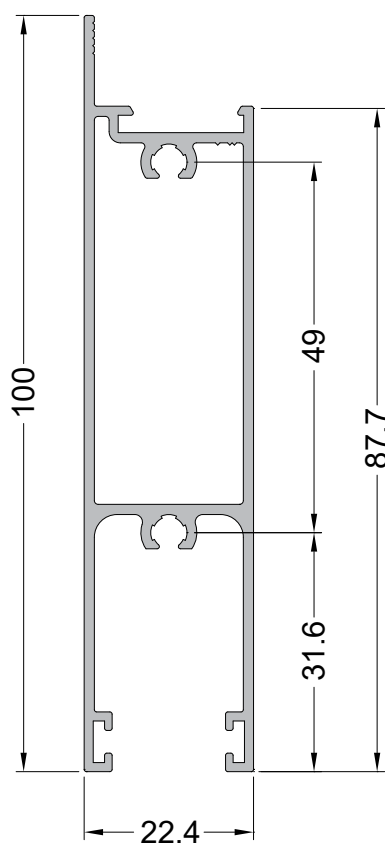

A-282 (ALG-03926)

0,522 Kg/m

Montante Lateral

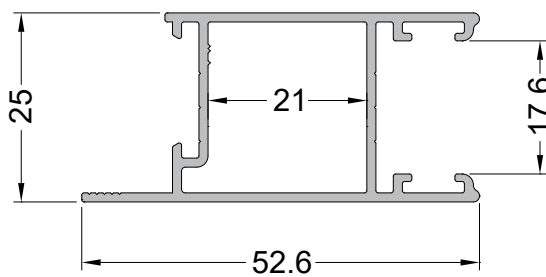

CX-324

0,524 Kg/m

Montante Central

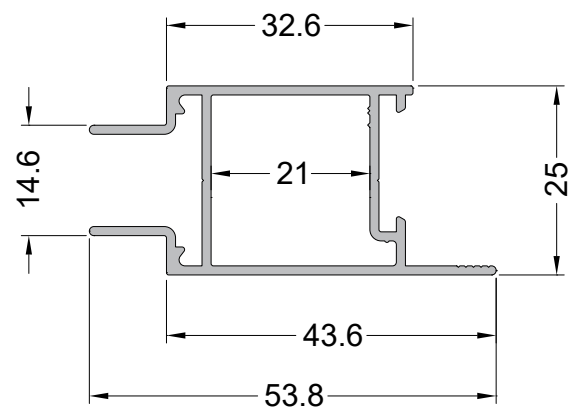

CX-314

0,710 Kg/m

Montante Lateral

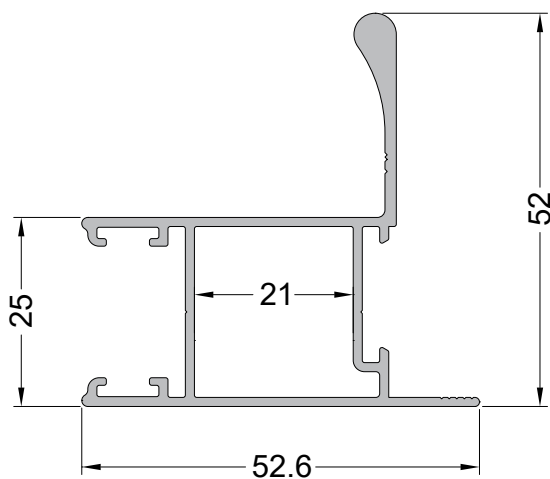

P-630 (ALG-04026)

0,479 Kg/m

Montante Mão de Amigo

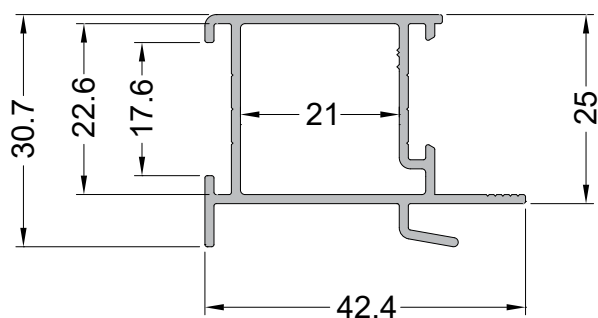

P-629 (ALG-04126)

0,508 Kg/m

Montante Mão de Amigo

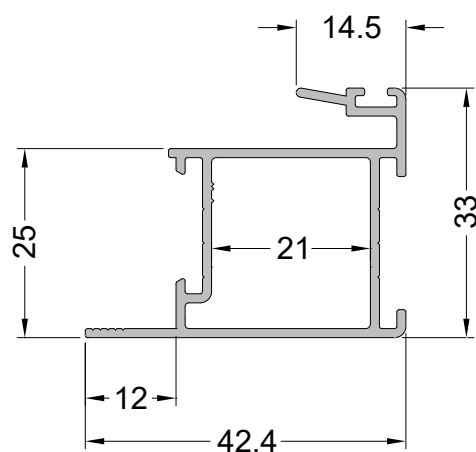

P-684 (ALG-05826)

0,462 Kg/m

Montante Mão de Amigo

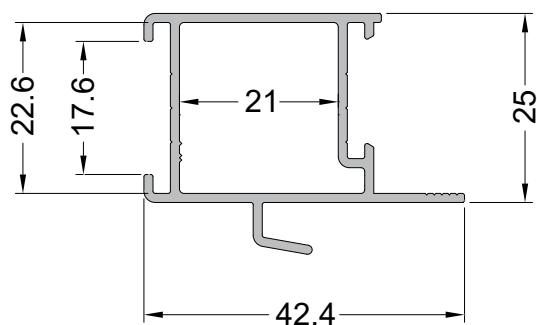

P-665 (ALG-04226)

0,572 Kg/m

Montante Mão de Amigo

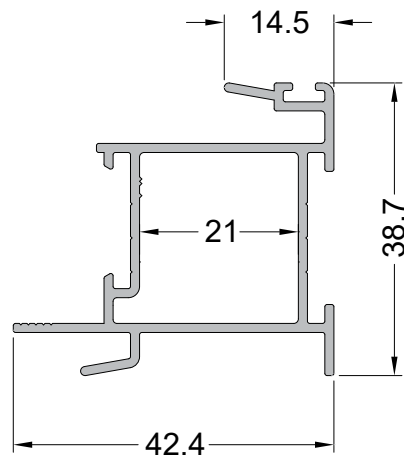

ALG-896 (ALG-28326)

1,098 Kg/m

Montante Lateral

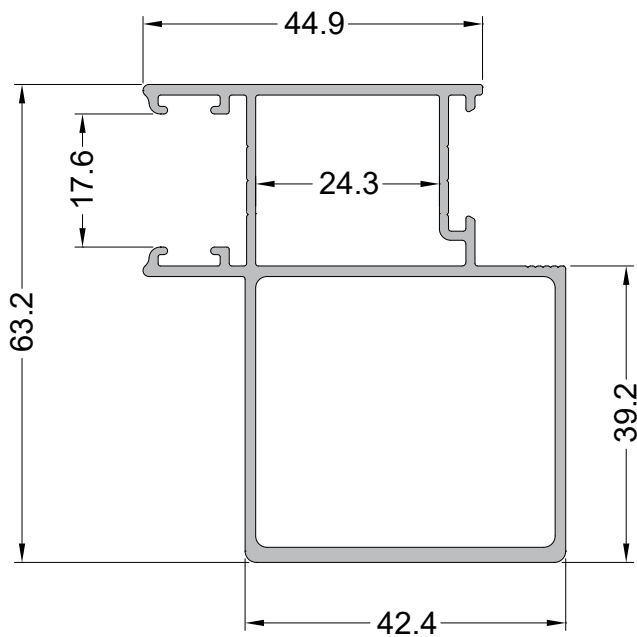

B-058 (ALG-04726)

0,980 Kg/m

Montante Mão de Amigo

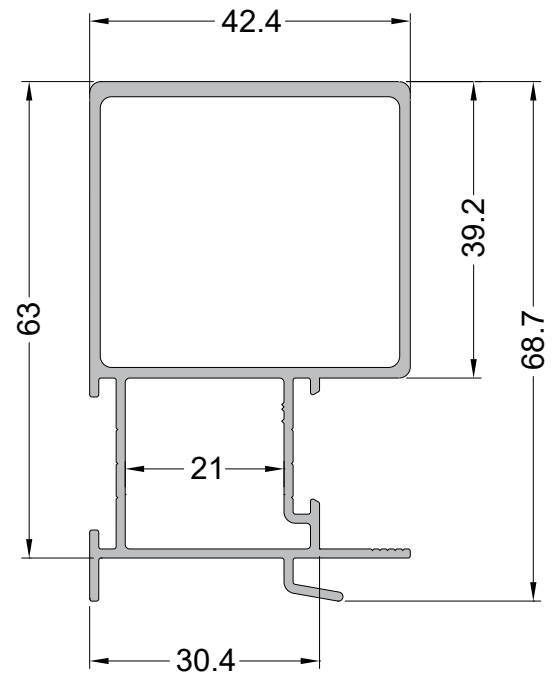

B-052 (ALG-04926)

1,024 Kg/m

Montante Mão de Amigo

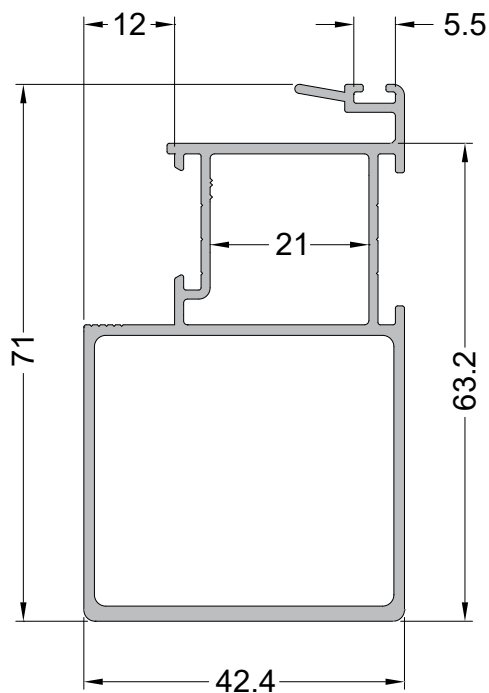

ALG-382

1,069 Kg/m

Montante Lateral

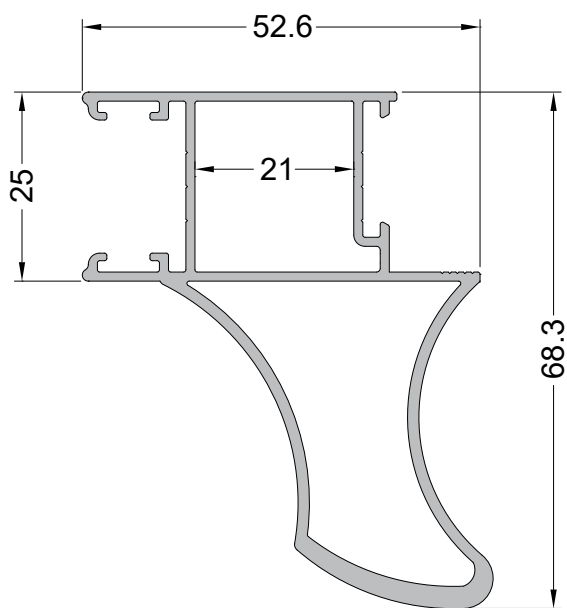

CX-609 (ALG-740)

1,071 Kg/m

Montante Mão de Amigo

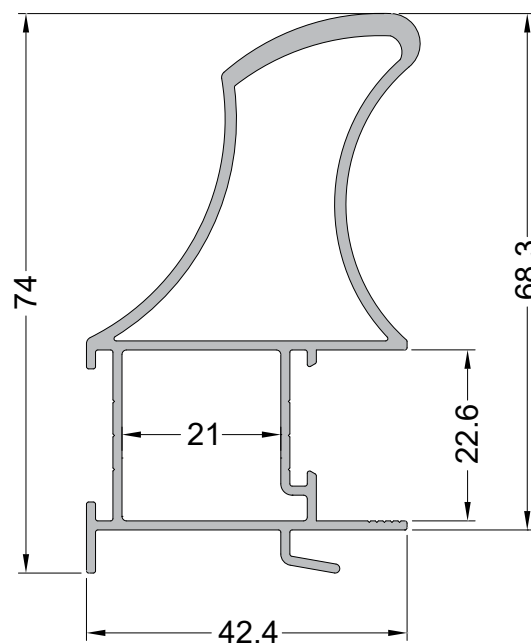

CX-608 (ALG-640)

1,065 Kg/m

Montante Mão de Amigo

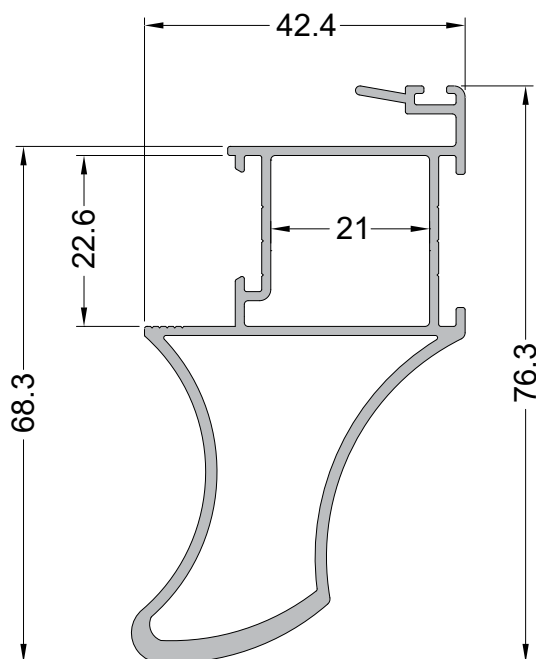

B-113

0,961 Kg/m

Montante Central

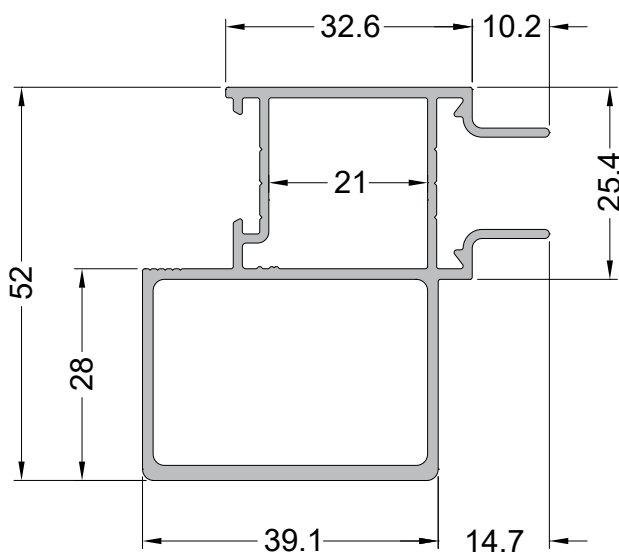

B-077 (ALG-04426)

0,837 Kg/m

Montante Lateral

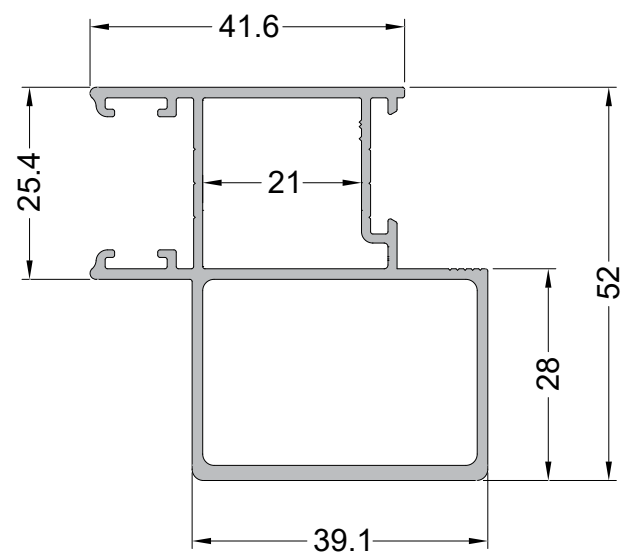

ALG-24526

0,626 Kg/m

Montante Lateral

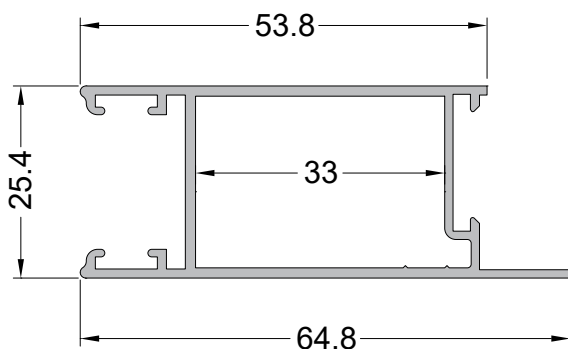

CX-557

0,872 Kg/m

Montante Lateral

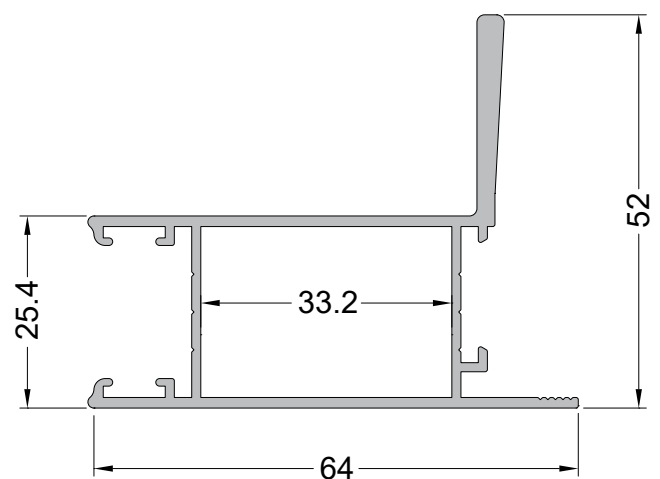

ALG-24326

0,716 Kg/m

Montante Mão de Amigo

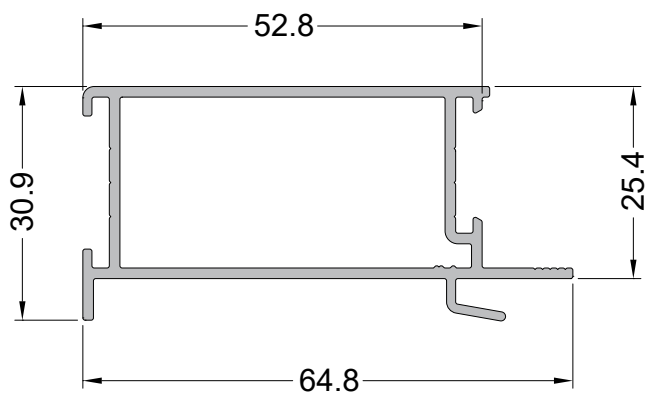

ALG-24226

0,746 Kg/m

Montante Mão de Amigo

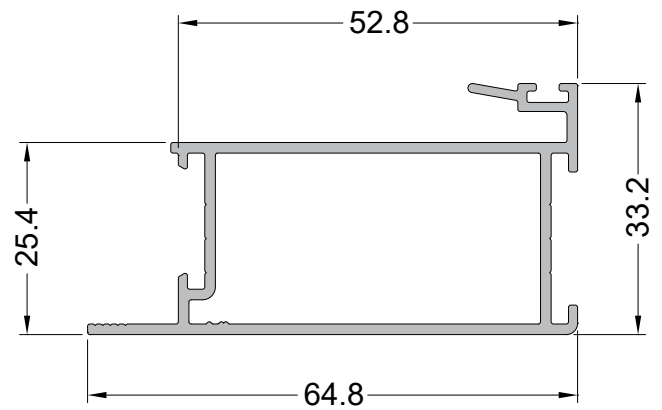

CX-308 (ALG-18626)

0,507 Kg/m

Travessa Folha

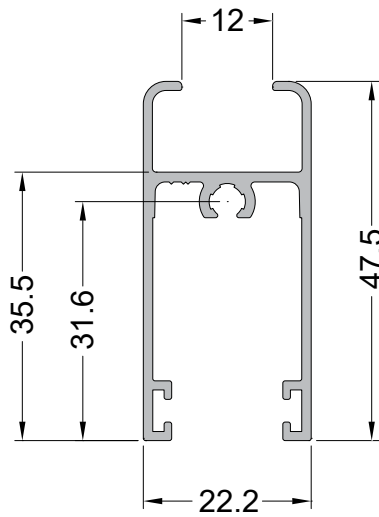

ALG-18826

0,598 Kg/m

Travessa Central Folha

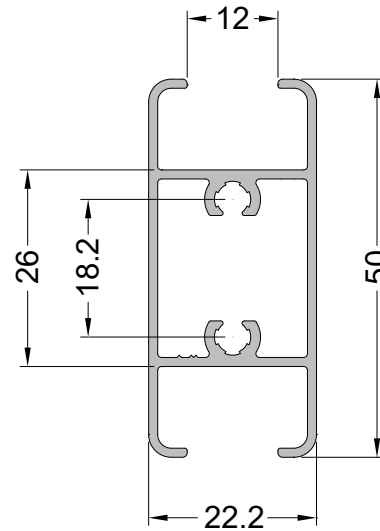

ALG-22626

1,010 Kg/m

Travessa Inferior Folha

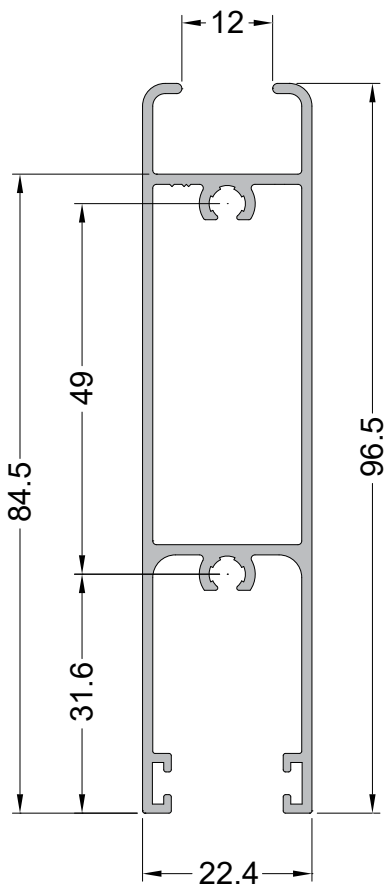



A-285 (ALG-05526)

0.543 Kg/m

Montante Lateral

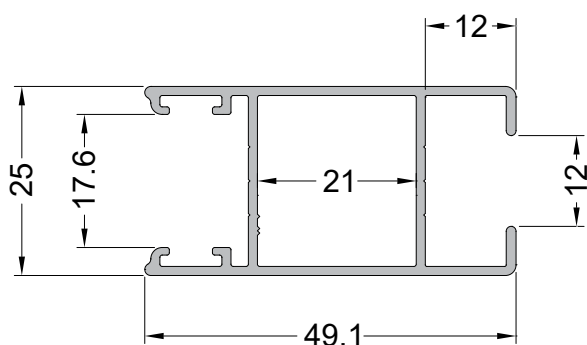

ALG-27026

0,749 Kg/m

Montante Lateral

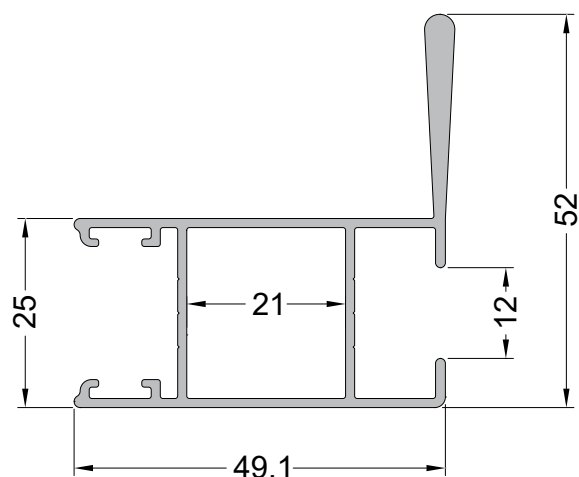

CX-633 (ALG-06426)

1,105 Kg/m

Montante Lateral

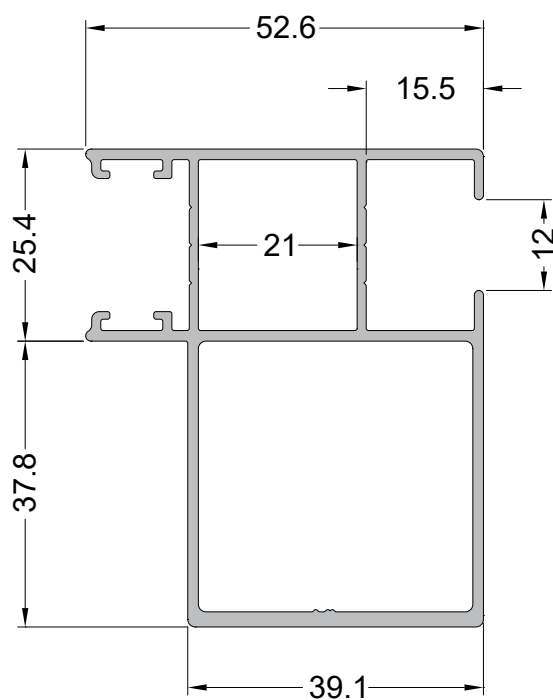

ALG-40301 (ALG-1012)

1,091 Kg/m

Montante Lateral

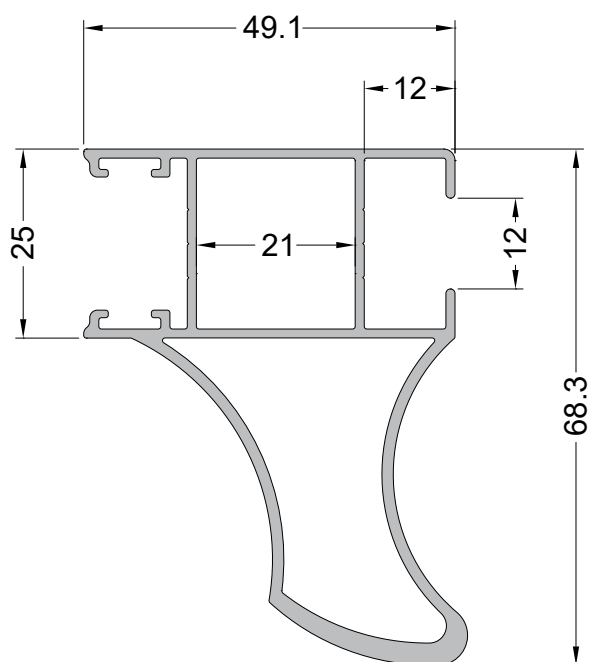

**B-078 (ALG-06026)**

0,965 Kg/m

Montante Lateral

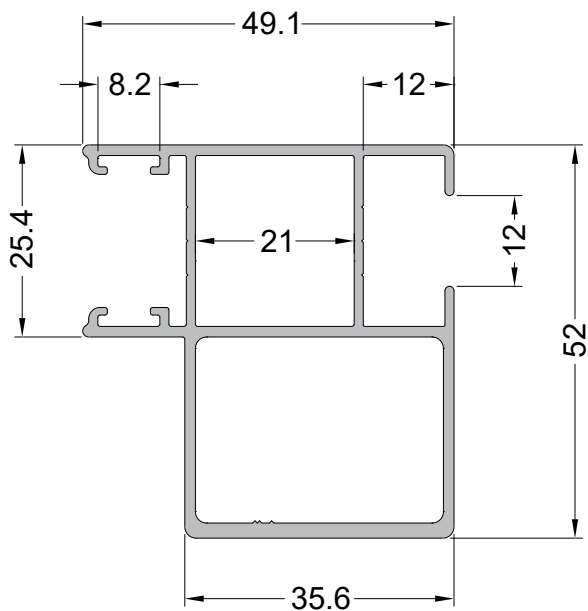

**A-273 (ALG-05626)**

0,538 Kg/m

Montante Mão de Amigo

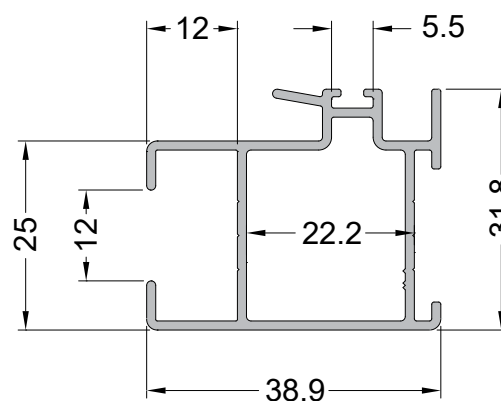

**ALG-06126**

1,052 Kg/m

Montante Mão de Amigo

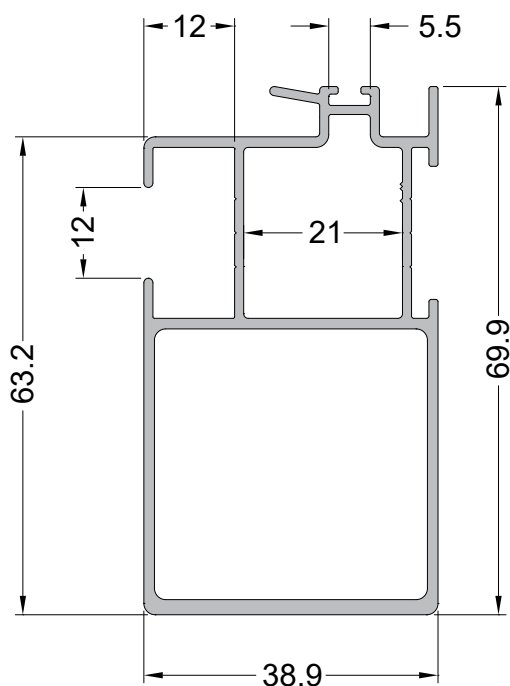

**ALG-40401 (ALG-1011)**

1,1097 Kg/m

Montante Mão de Amigo

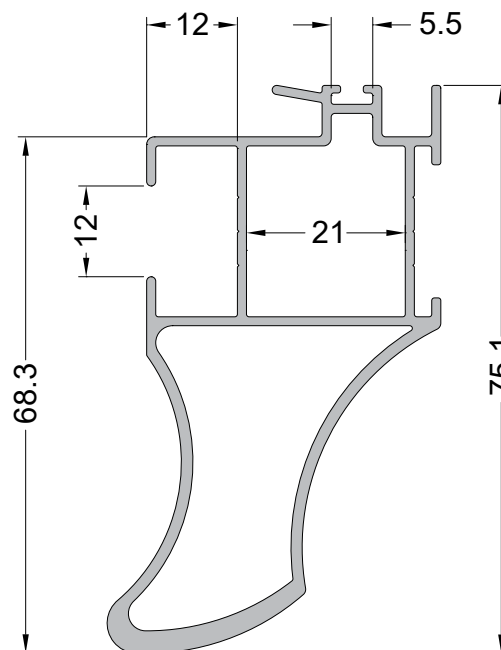

A-279 (ALG-05726)

0,628 Kg/m

Montante Mão de Amigo

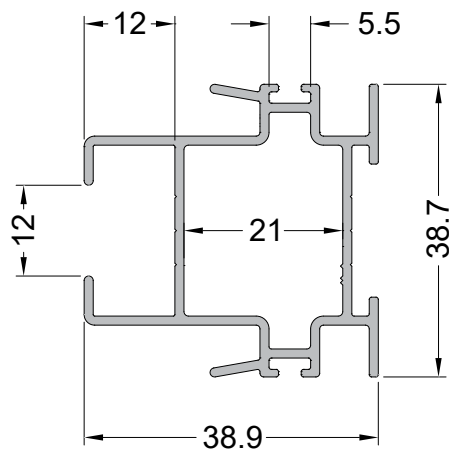

ALG-23826

0,714 Kg/m

Montante Lateral

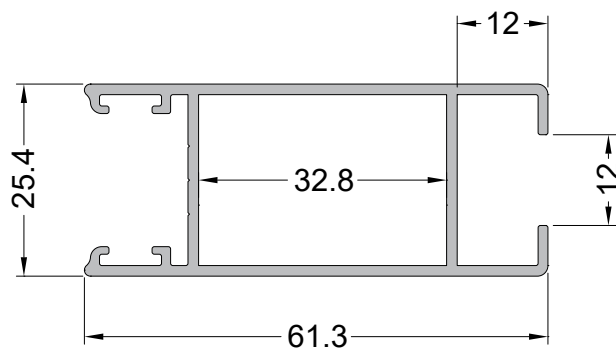

U-1264 (ALG-10726)

0,271 Kg/m

Vedação do Montante

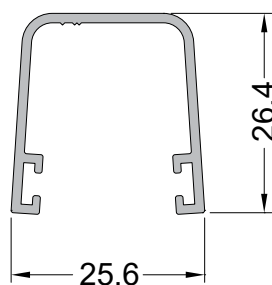

CX-3114

0,271 Kg/m

Complemento

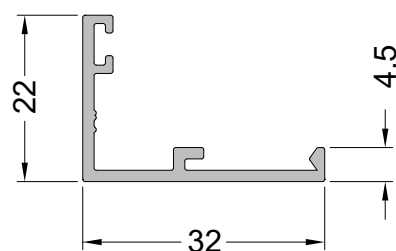

CX-315 (ALG-18726)

0,472 Kg/m

Travessa Folha

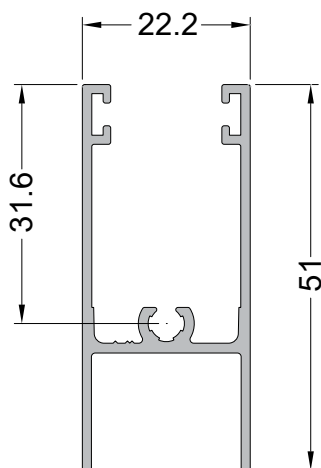

A-284 (ALG-06826)

0,533 Kg/m

Montante Lateral

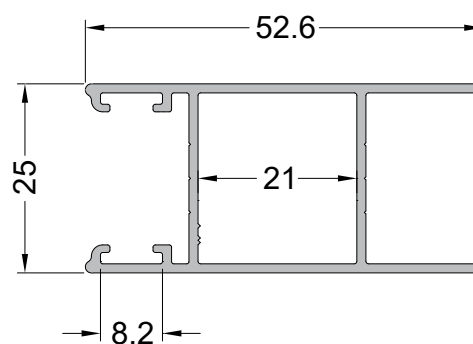

A-246 (ALG-07026)

0,520 Kg/m

Montante Mão de Amigo

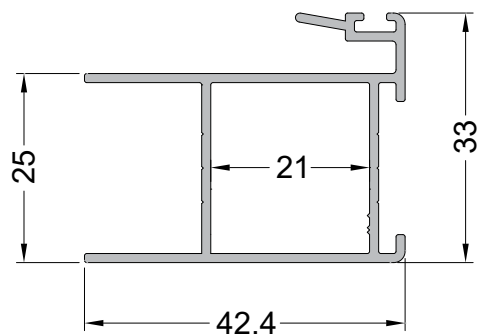

A-254 (ALG-06926)

0,574 Kg/m

Montante Mão de Amigo

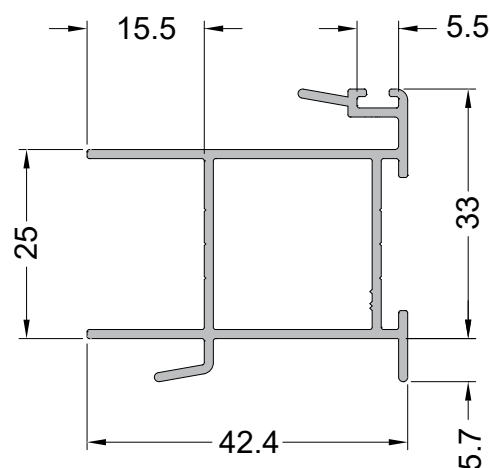

U-1233 (ALG-09326)

0,282 Kg/m

Marco

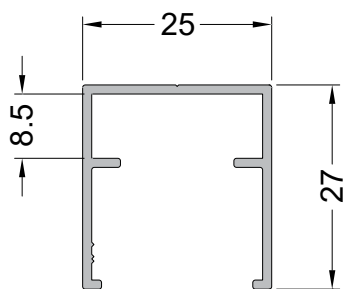

D-185

0.374 Kg/m

Tubo

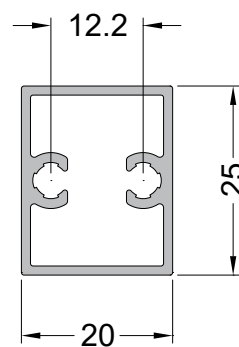

P-643 (ALG-09726)

0,401 Kg/m

Folha

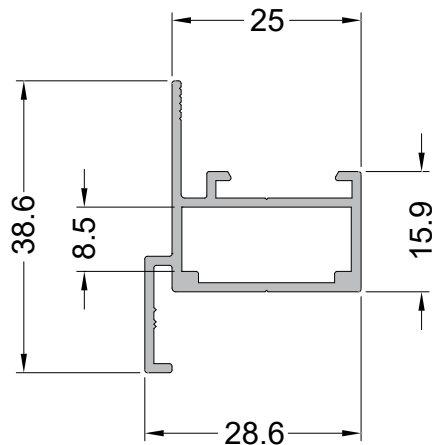

P-644 (ALG-09826)

0,407 Kg/m

Folha

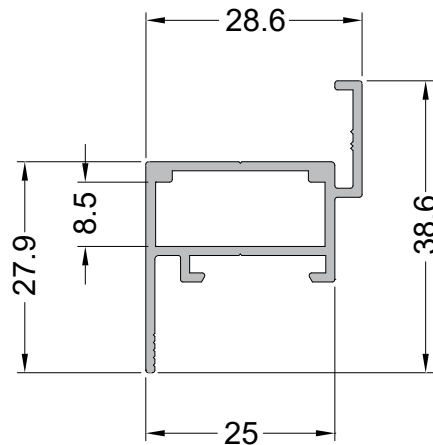

P-642 (ALG-09626)

0,314 Kg/m

Folha

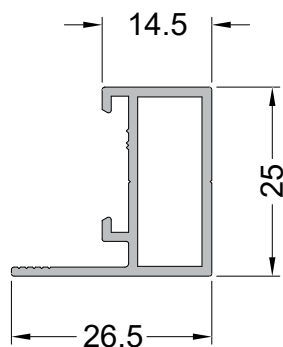

CX-318  
 0,585 Kg/m  
 Marco

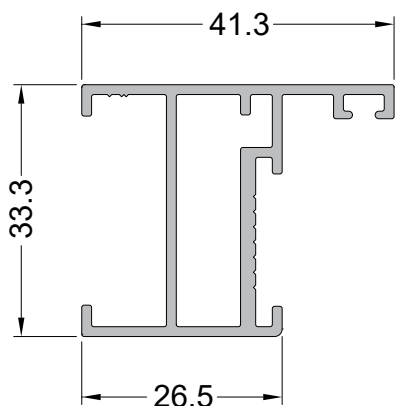

A-253  
 0,538 Kg/m  
 Travessa Folha

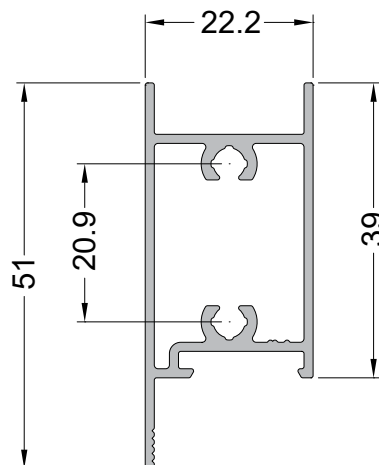

P-693  
 0,482 Kg/m  
 Folha

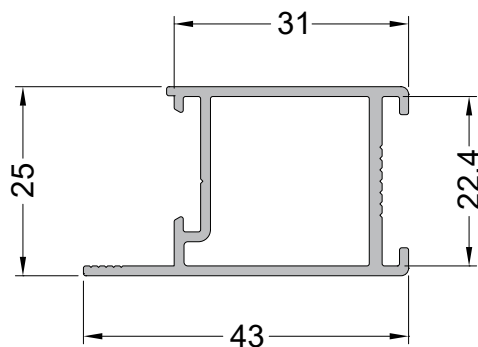

CX-316  
 0,620 Kg/m  
 Folha

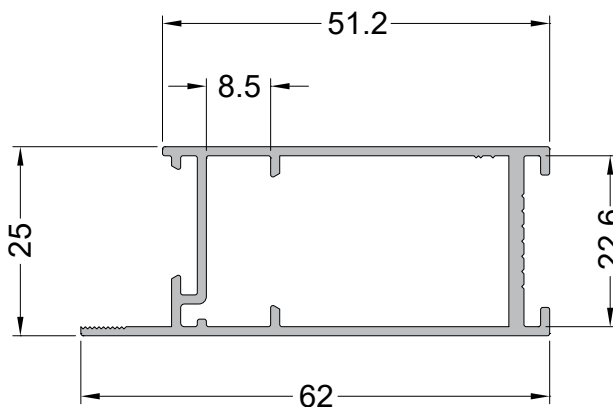

CX-3090  
 0,668 Kg/m  
 Folha

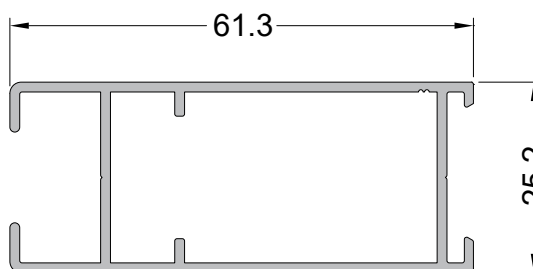

Y-782 (ALG-07126)

0,279 Kg/m

Marco

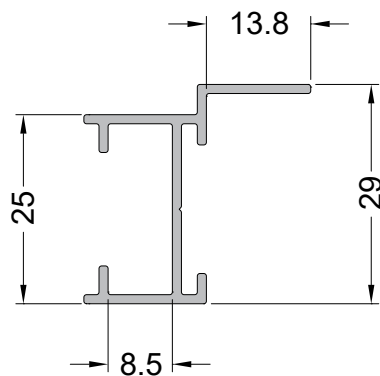

P-645 (ALG-07326)

0,449 Kg/m

Travessa Folha

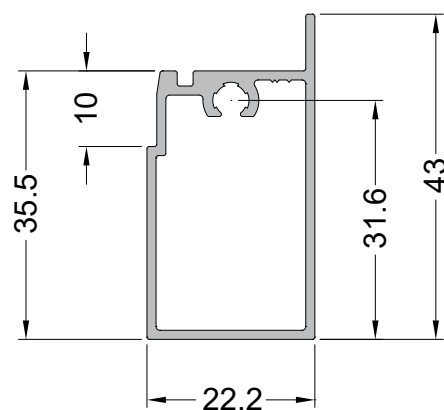

A-251 (ALG-07226)

0,436 Kg/m

Montante Folha

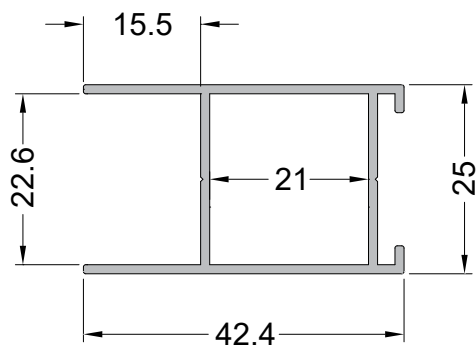

A-252 (ALG-07426)

0,501 Kg/m

Montante Folha

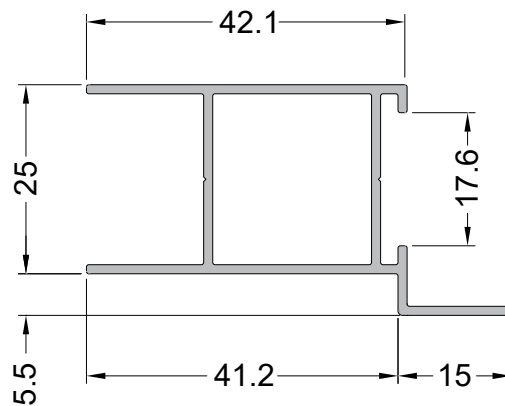

CX-3218  
0.362 Kg/m  
Marco

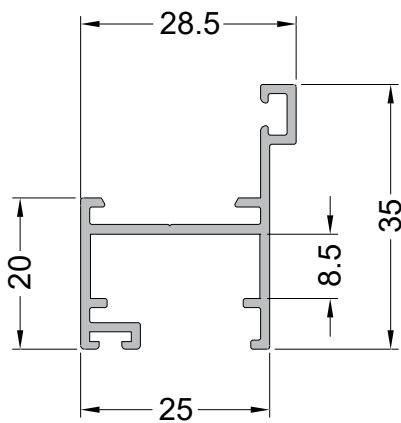

Y-779 (ALG-07926)  
0,333 Kg/m  
Marco

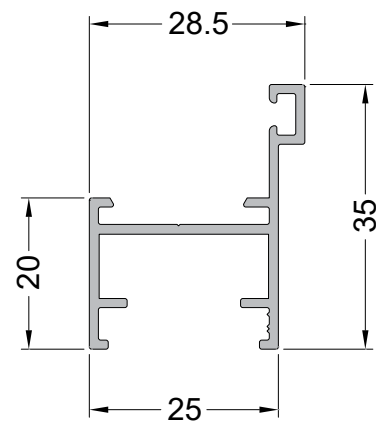

CX-3161  
0.437 Kg/m  
Marco

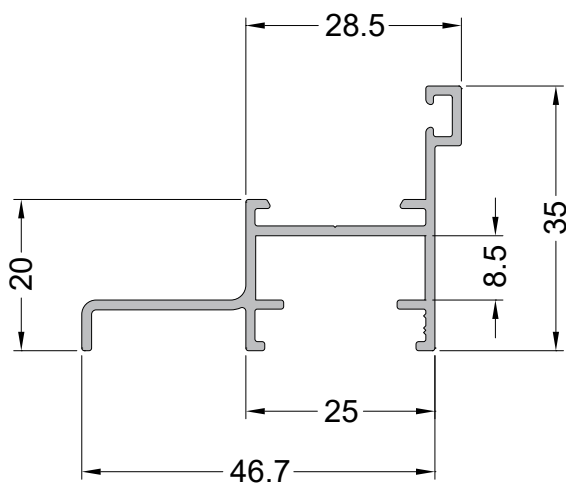



Y-802 (ALG-03026)

0,802 Kg/m

Marco

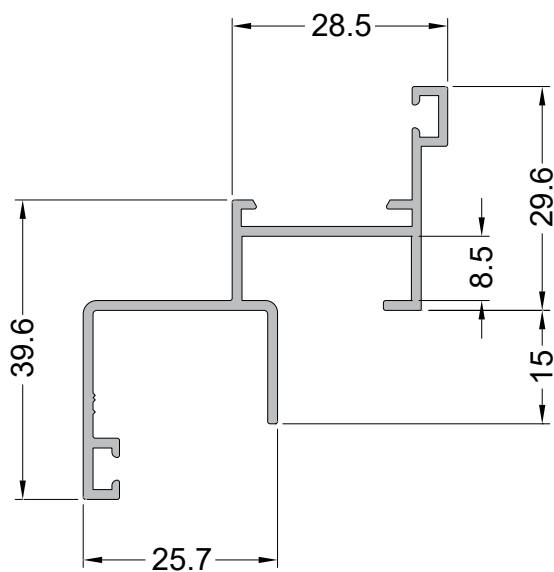

L-794

0,143 Kg/m

Pingadeira Marco Max

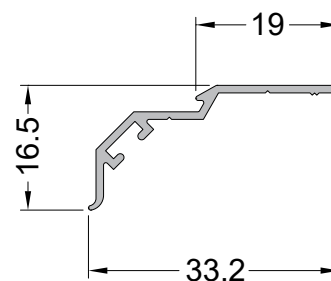

P-640 (ALG-08626)

0,589 Kg/m

Coluna

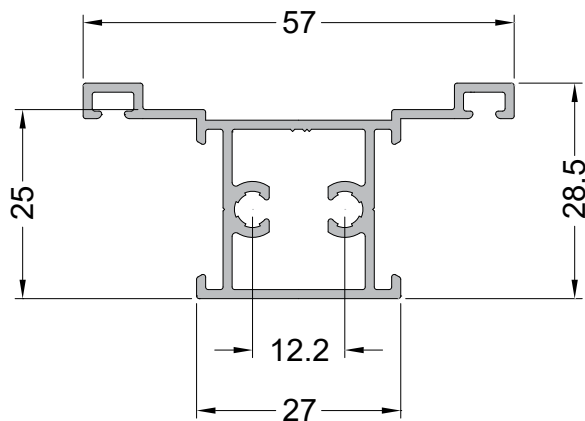

P-641 (ALG-08526)

0,497 Kg/m

Travessa

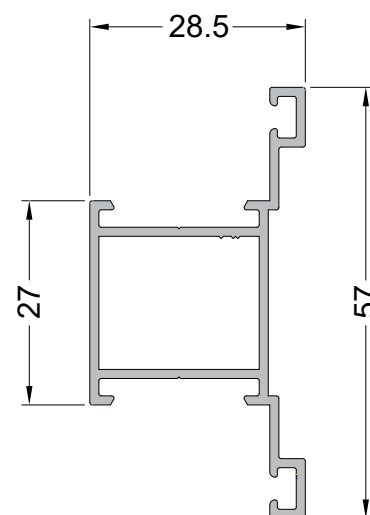

P-638 (ALG-08226)

0,379 Kg/m

Folha Max

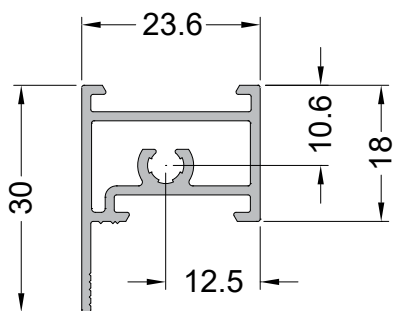

P-639 (ALG-08026)

0,342 Kg/m

Folha Max

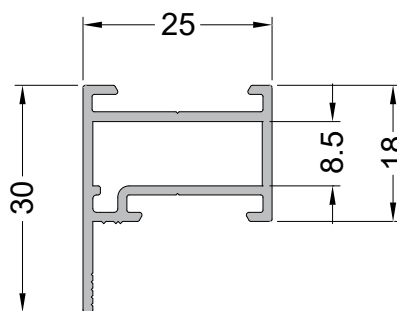

CX-309 (ALG-20026)

0,422 Kg/m

Folha Max

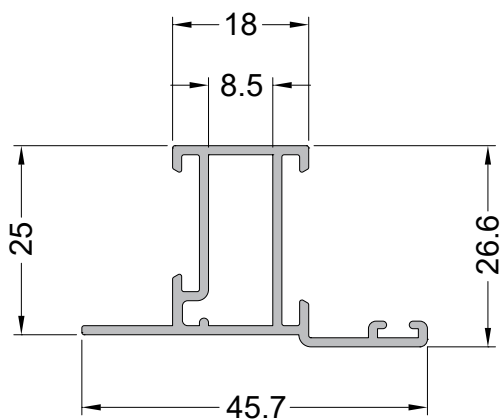

P-637 (ALG-08126)

0,404 Kg/m

Folha Max

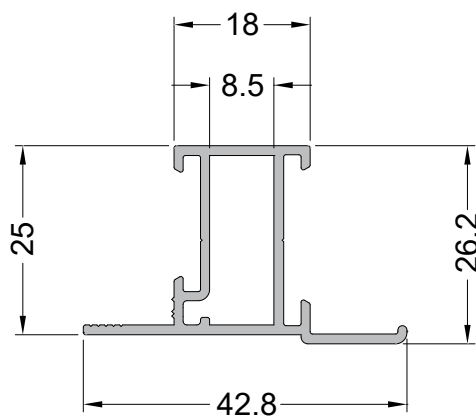

ALG-09126

0,331 Kg/m

Folha Max

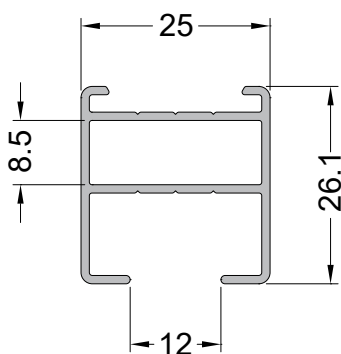

ALG-09026

0,380 Kg/m

Folha Max

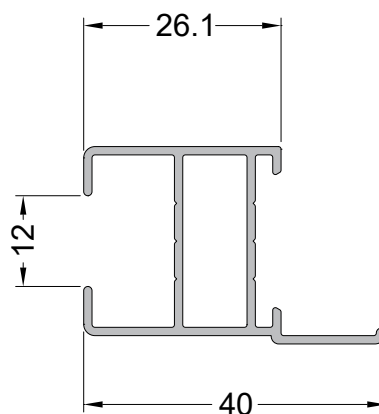

CX-3217

0,481 Kg/m

Folha Max

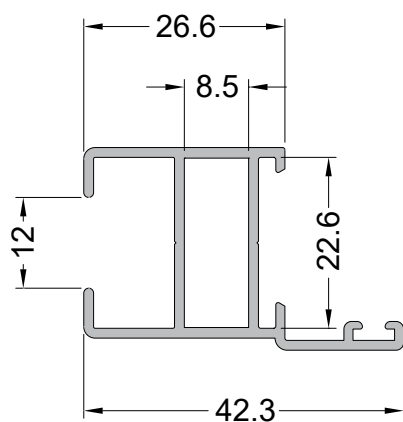

L-795 (ALG-08426)

0,125 Kg/m

Pingadeira Folha Max

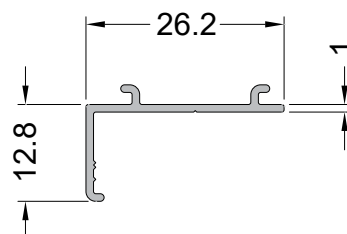

**Y-807 (ALG-08826)**

0,292 Kg/m

Junção Marco

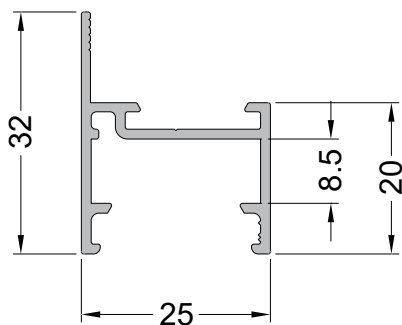

**CX-607 (ALG-29226)**

0,218 Kg/m

Inversor para Baguete

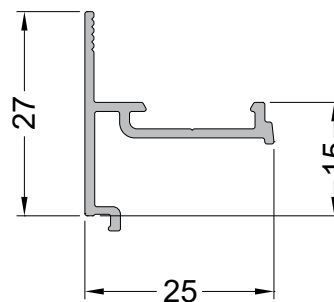

**U-1230 (ALG-10226)**

0,109 Kg/m

Baguete

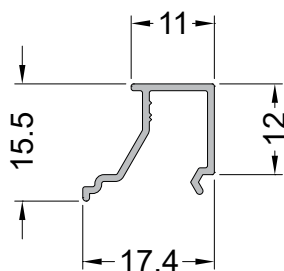

**ALG-810**

0,104 Kg/m

Baguete

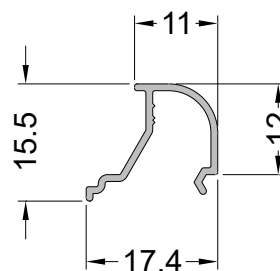

**U-1231 (ALG-10326)**

0,141 Kg/m

Baguete

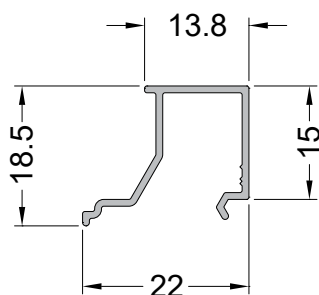

**ALG-895**

0,108 Kg/m

Baguete

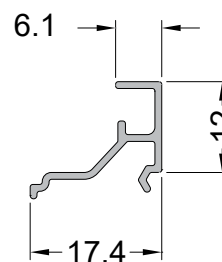

L-797 (ALG-10826)

0,124 Kg/m

Complemento Veneziana

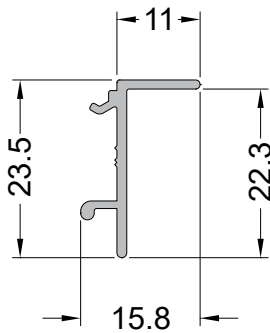

ALG-20326

0,133 Kg/m

Baguete

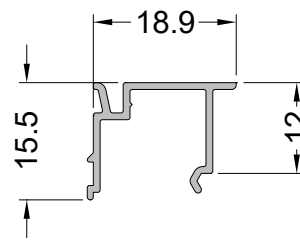

T-215

0.157 Kg/m

Perfil T

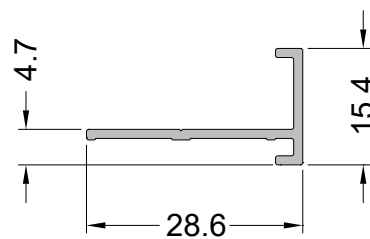

ALG-01102 (BK-5059)

0.843 Kg/m

Marco Superior

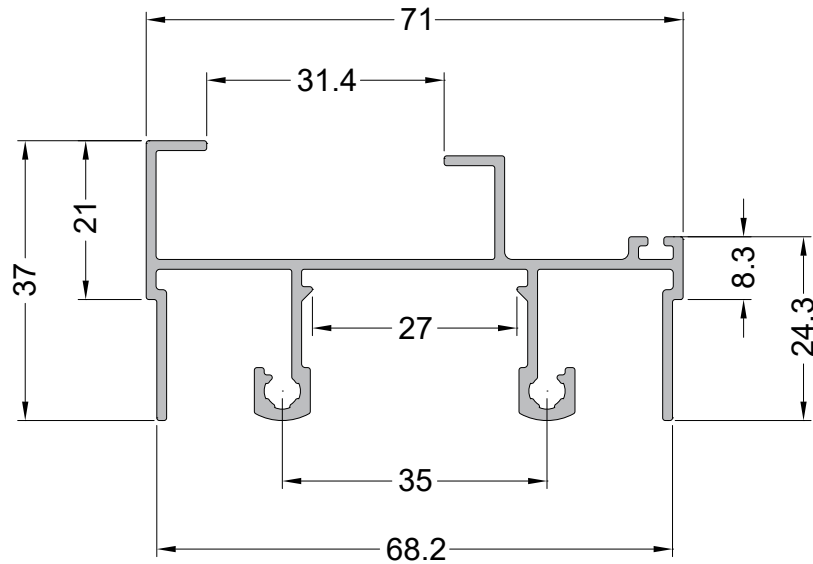

ALG-01001 (BK-5051)

0.799 Kg/m

Marco Inferior

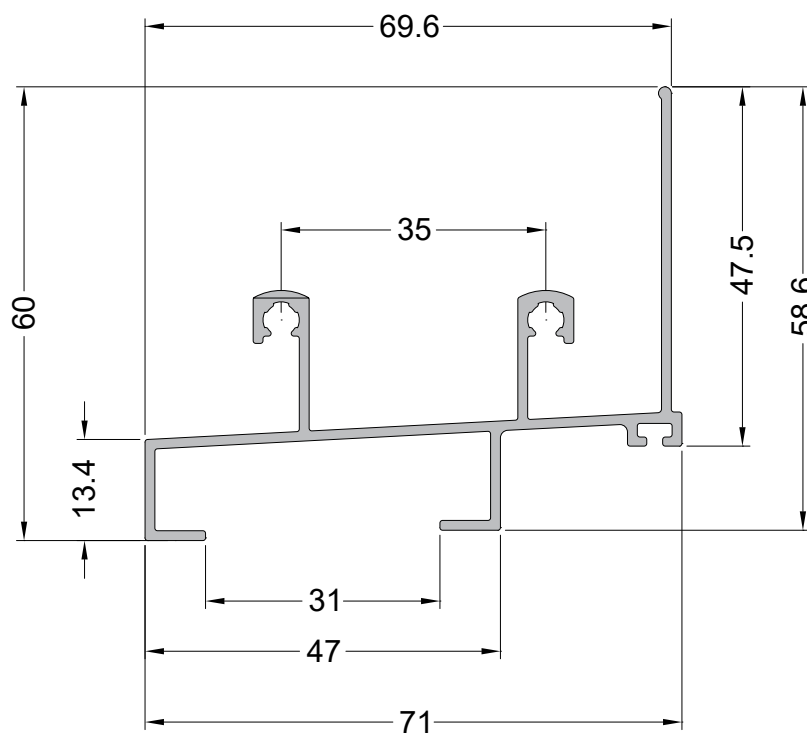

ALG-01103 (BK-5053)

1.109 Kg/m

Marco Superior

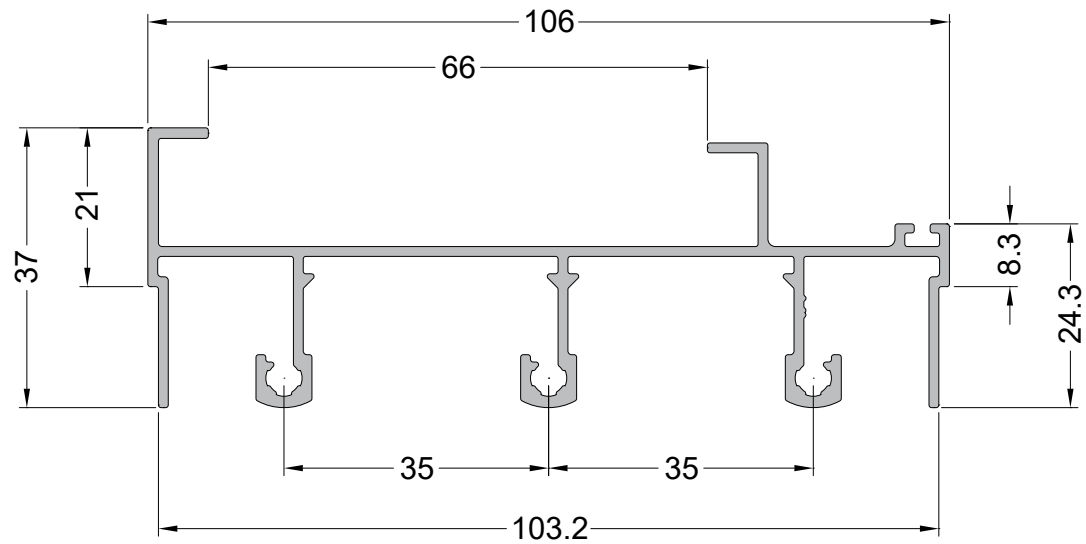

ALG-01002 (BK-5054)

1.070 Kg/m

Marco Inferior

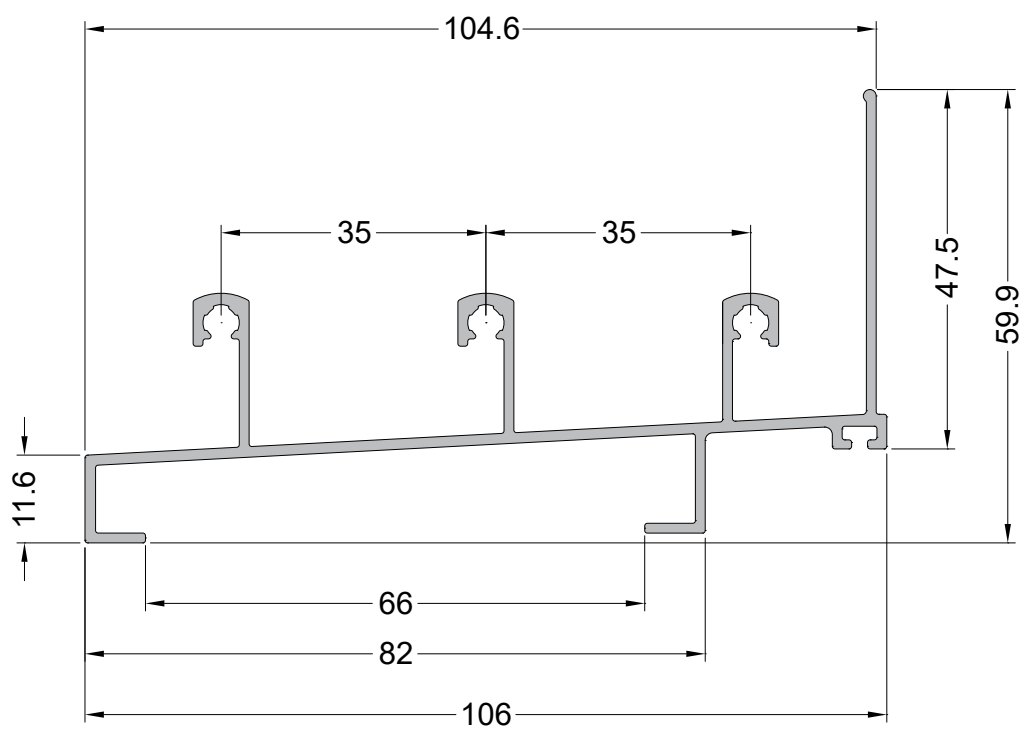

ALG-01302 (BK-5052)

0.474 Kg/m

Marco Lateral

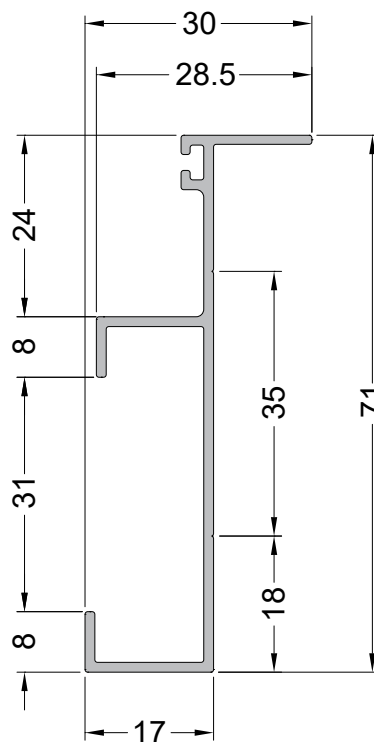

ALG-01303 (BK-5055)

0.630 Kg/m

Marco Lateral

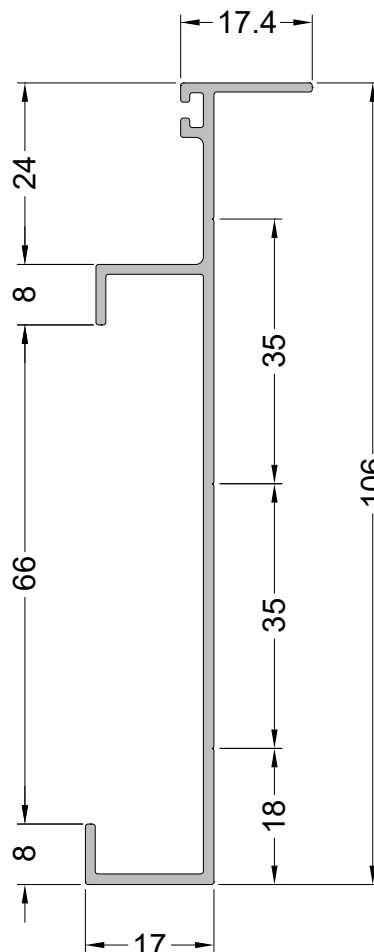



ALG-04601 (BK-5056)

0.610 Kg/m

Marco

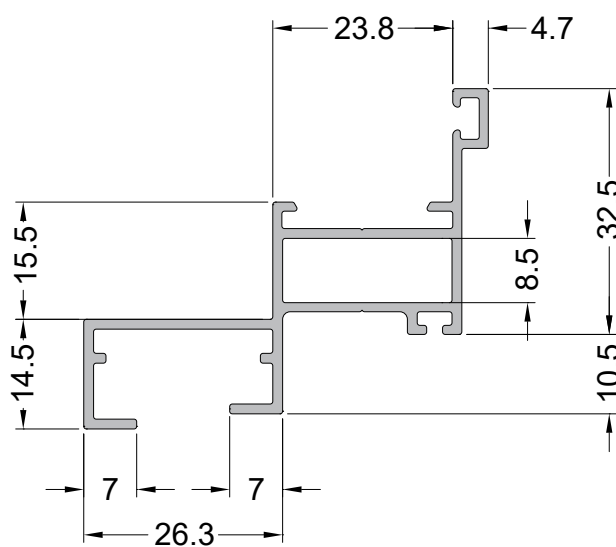

ALG-00601 (BK-5058)

0.274 Kg/m

Complemento

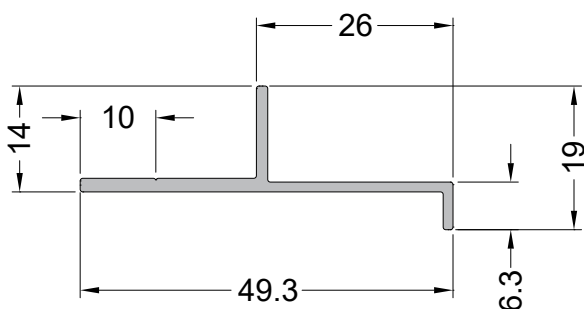

ALG-86601 (BK-5057)

0.095 Kg/m

Complemento

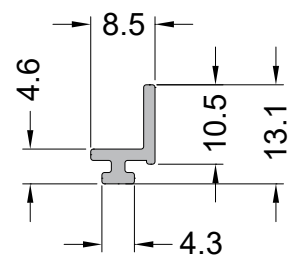

ALG-01101

0,814 Kg/m

Trilho Individual

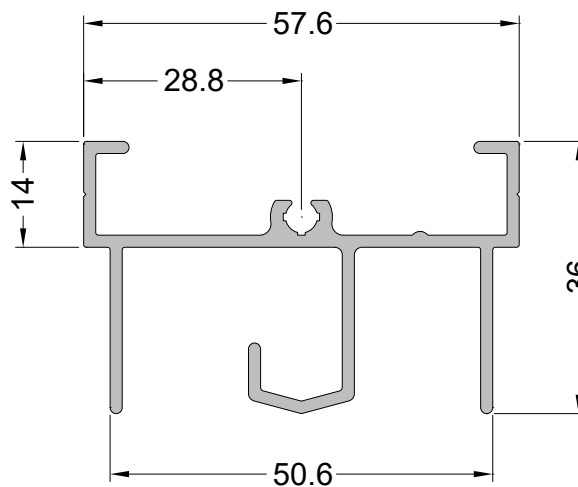

CX-505 (ALG-3301)

1,244 Kg/m

Marco Superior

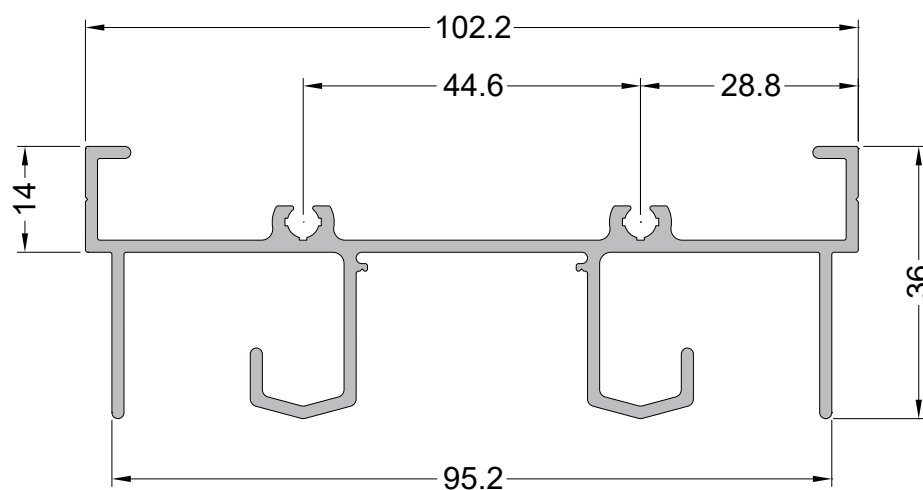

CX-506 (ALG-3306)

1,138 Kg/m

Marco Inferior

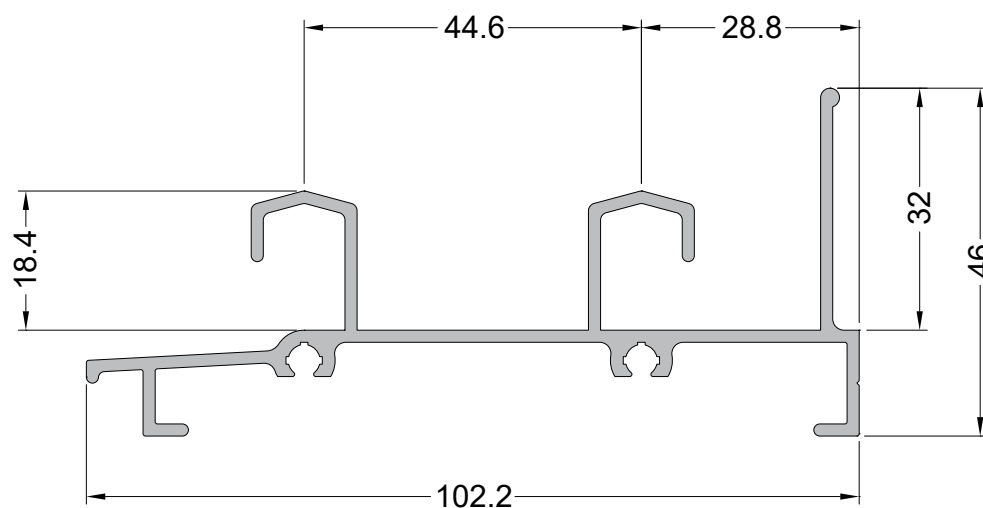

ALG-3024  
1,243 Kg/m  
Marco Inferior

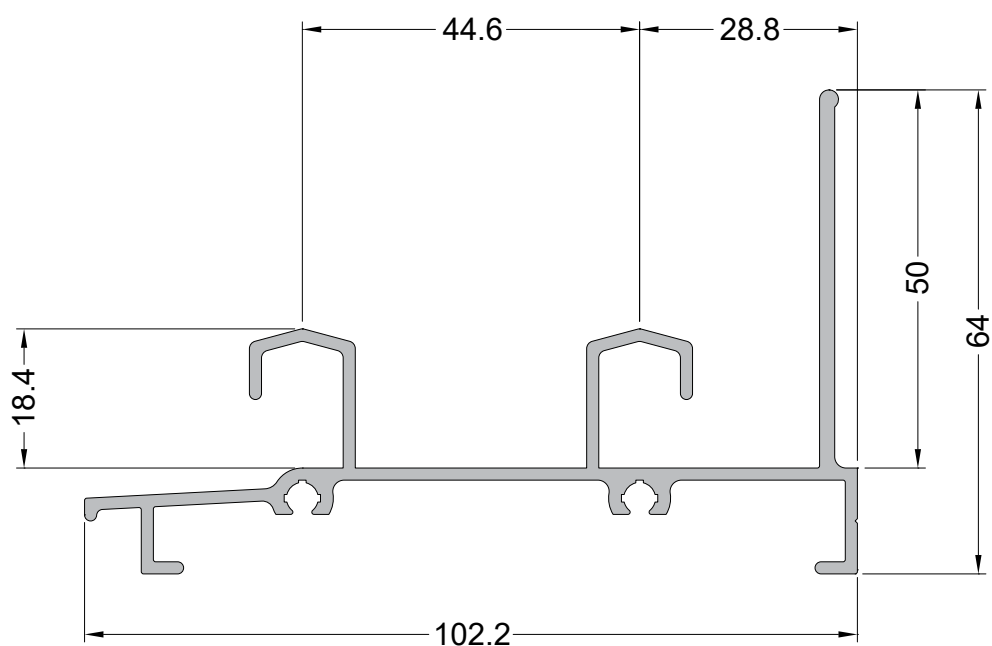

ALG-4003  
0,708 Kg/m  
Marco Travessa

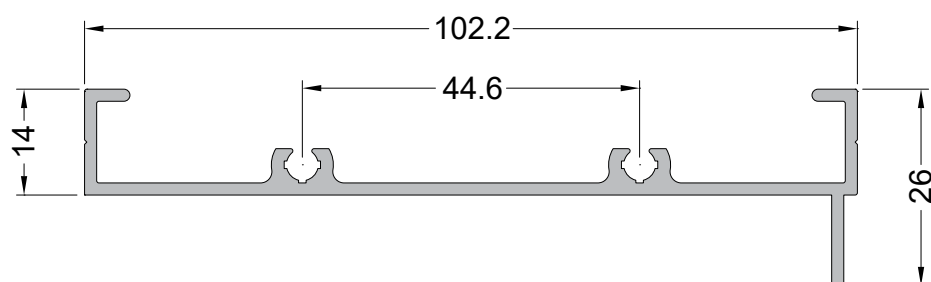

ALG-3061  
0,316 Kg/m  
Trilho Individual

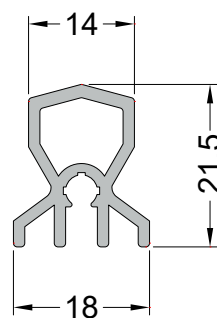

ALG-20101

2,045 Kg/m

Marco Intermediário  
Bandeira

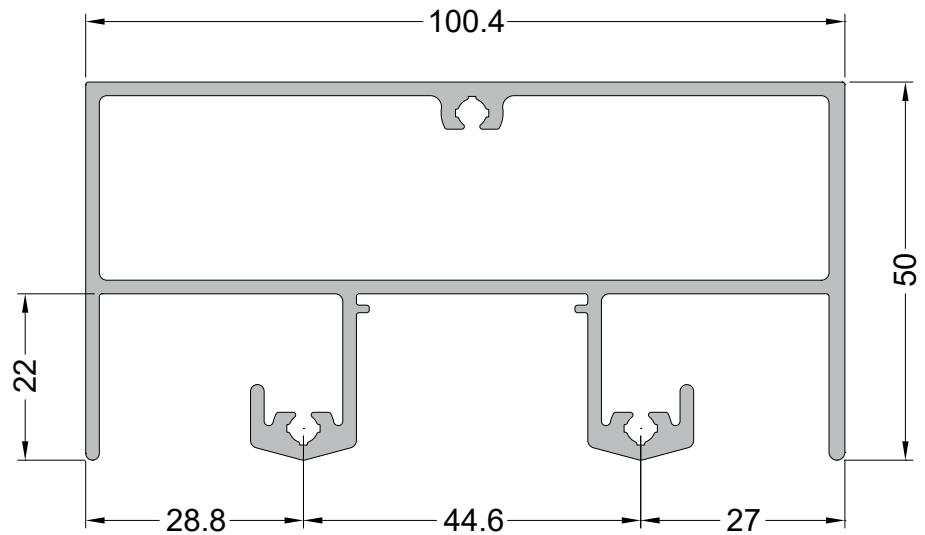

ALG-4004

2,113 Kg/m

Marco Intermediário  
Bandeira

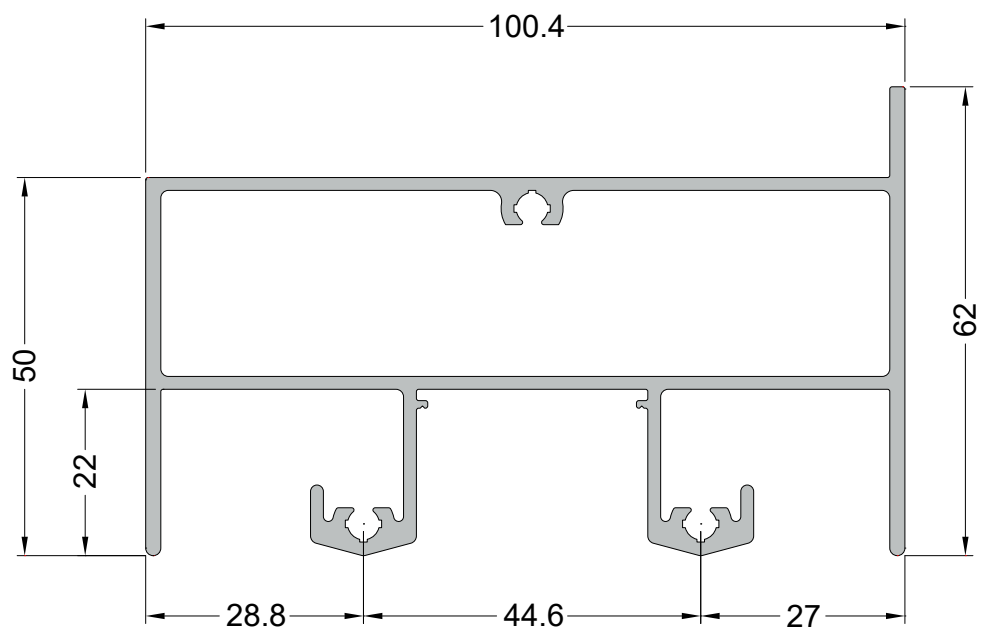

### ALG-4005

2,113 Kg/m

Marco Intermediário  
Peitoril

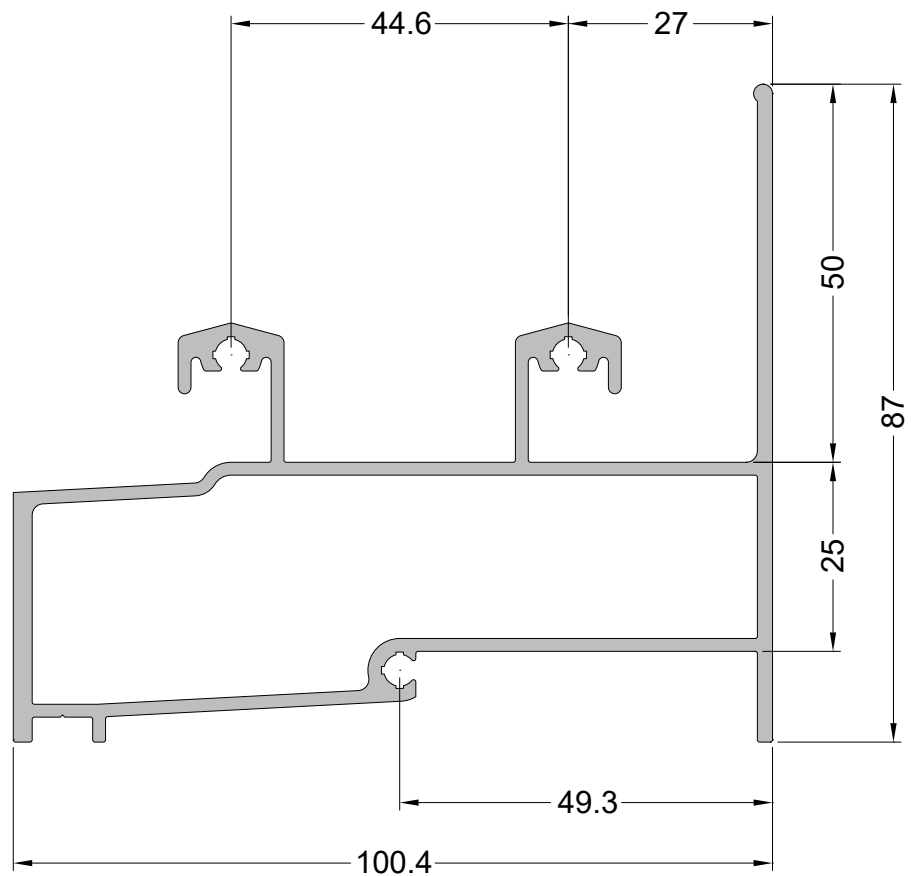

### ALG-76301

1,313 Kg/m

Coluna

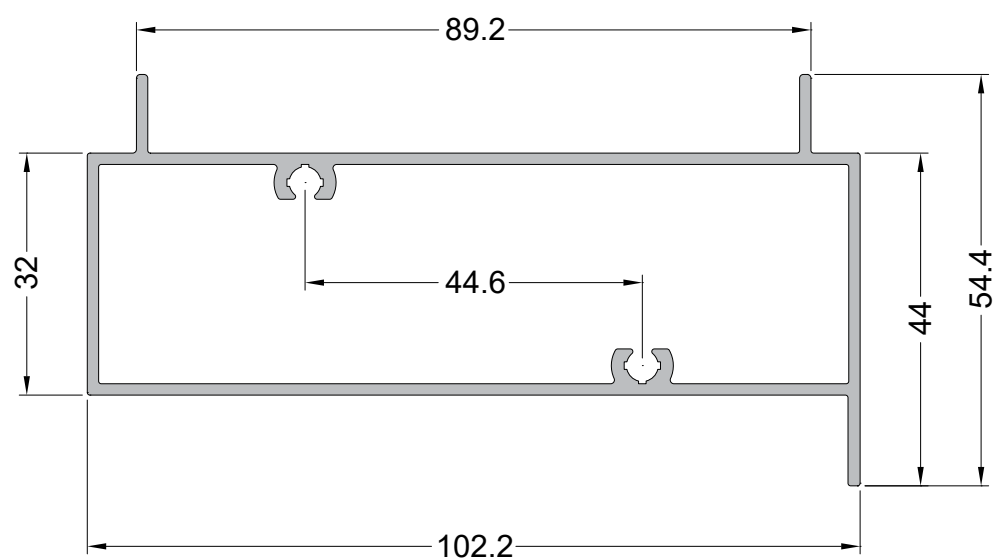

ALG-4002  
0,601 Kg/m  
Marco Lateral Liso

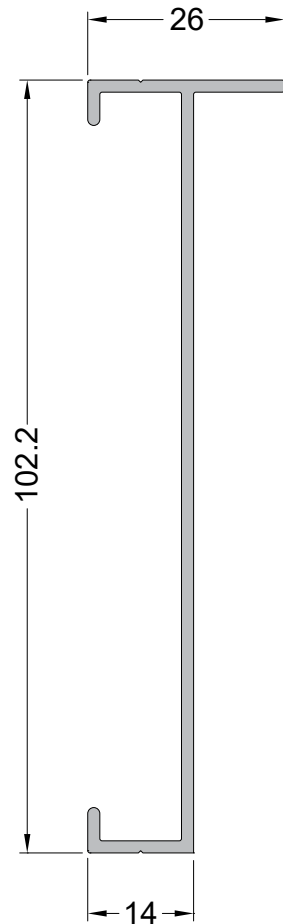

ALG-3304  
0,953 Kg/m  
Marco Lateral

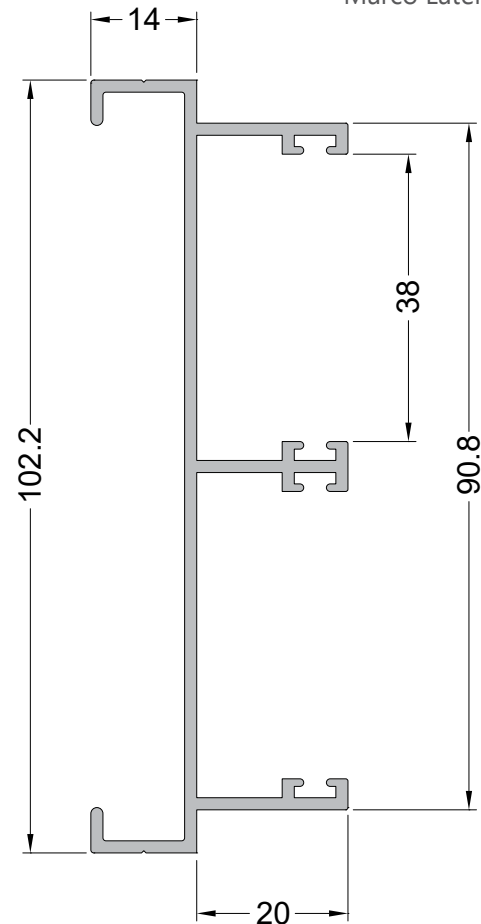

ALG-3028  
0,433 Kg/m  
Mata-Junta

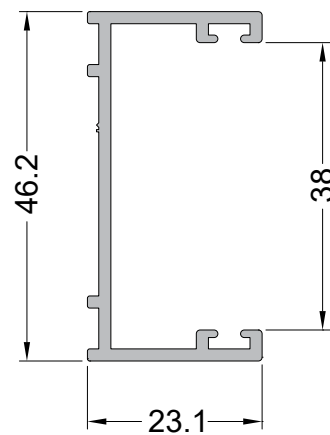

ALG-01301  
0,625 Kg/m  
Mata-Junta

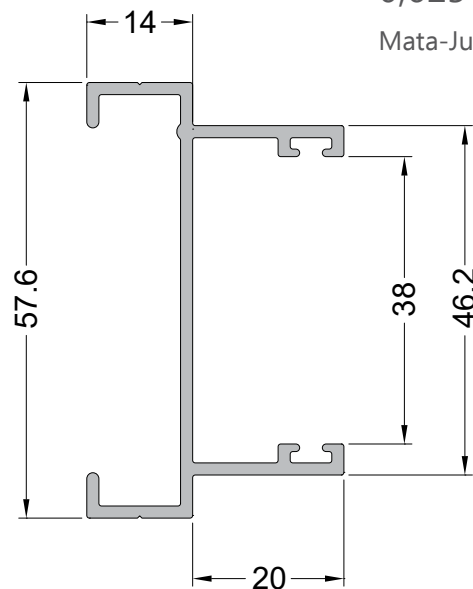

ALG-3343

1,718 Kg/m

Marco Superior

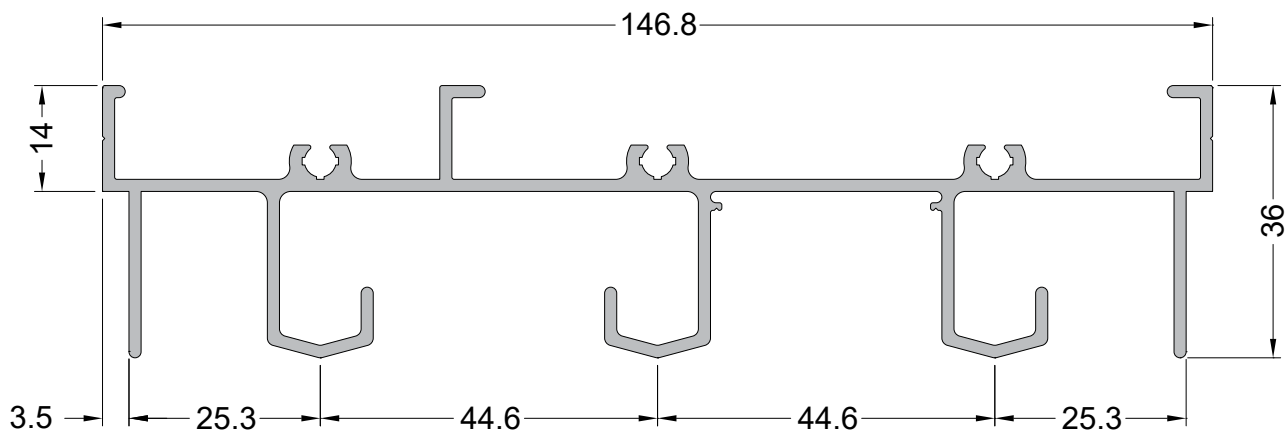

ALG-3364

1,523 Kg/m

Marco Inferior

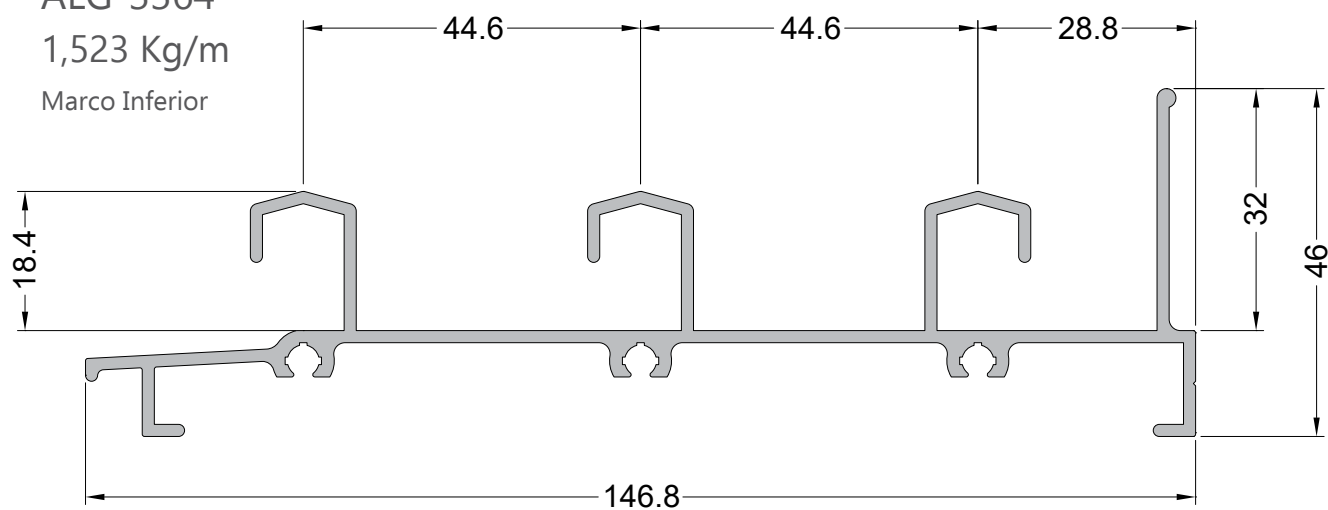

ALG-3158

0,996 Kg/m

Marco Travessa

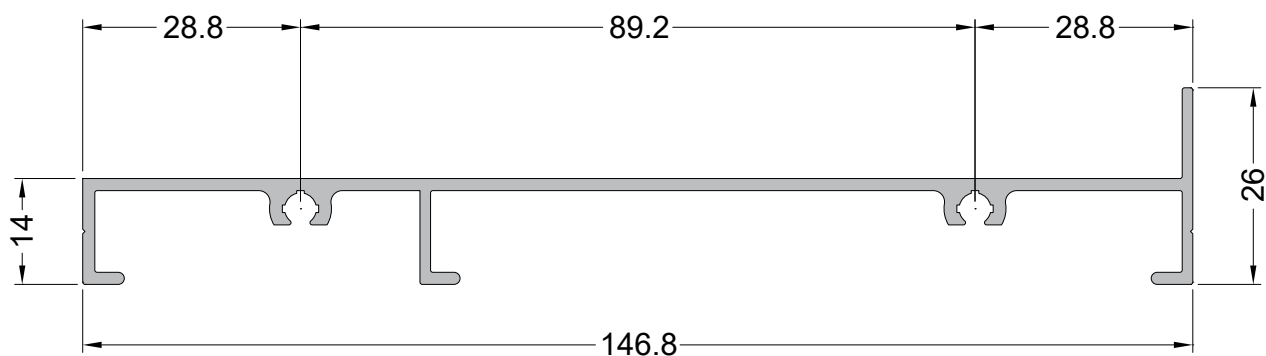

ALG-3064  
1,358 Kg/m  
Marco Lateral

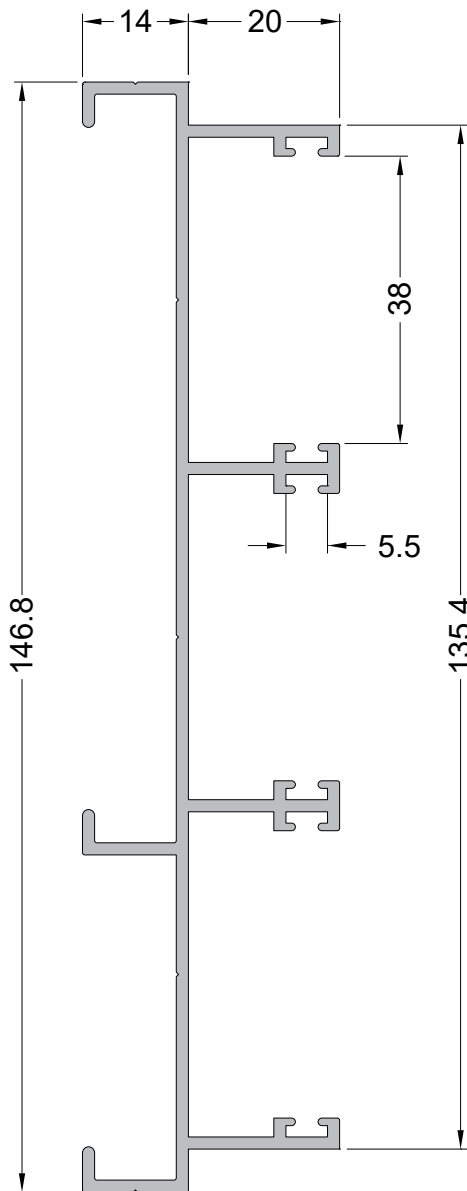

ALG-3305  
0,207 Kg/m  
Tampa

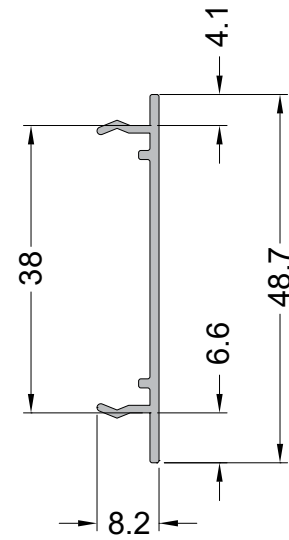



ALG-3008  
1,458 Kg/m  
Marco Superior

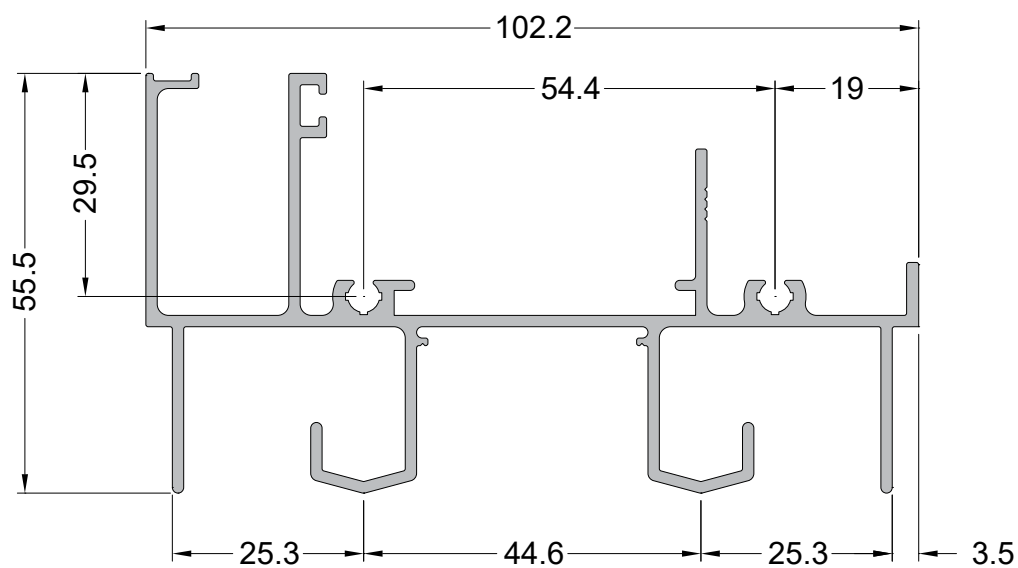

ALG-3025  
1,545 Kg/m  
Marco Inferior

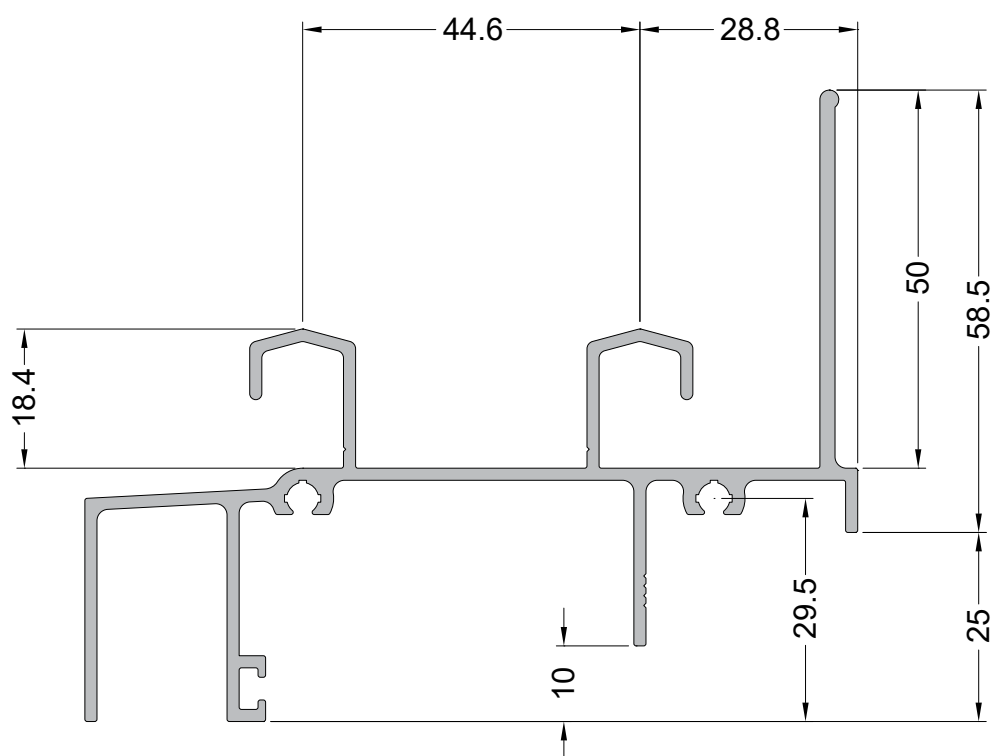

ALG-3009  
1,004 Kg/m  
Marco Travessa

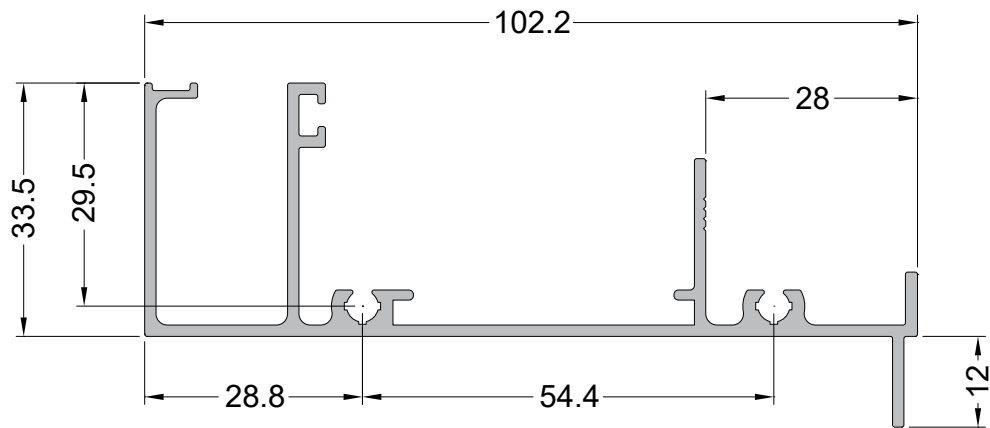

ALG-3010  
0,887 Kg/m  
Marco Lateral

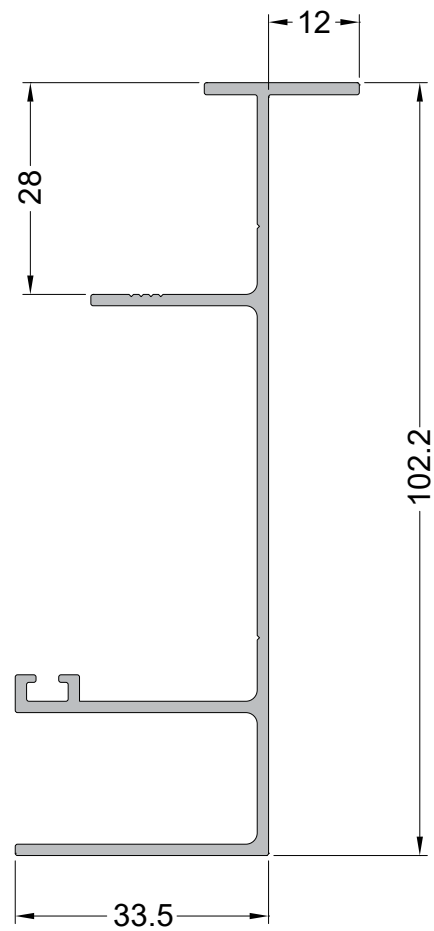

MN-001

1.377 Kg/m

Marco Superior

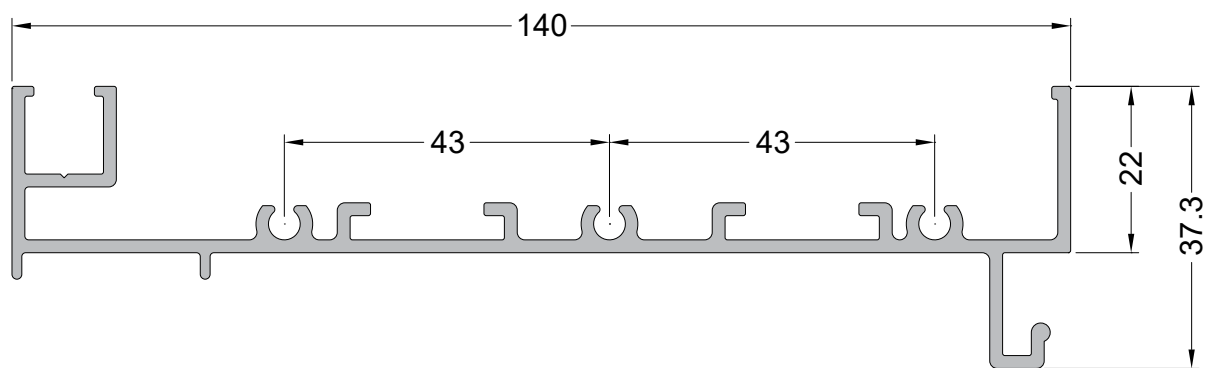

ALG-030

1,807 Kg/m

Marco Inferior

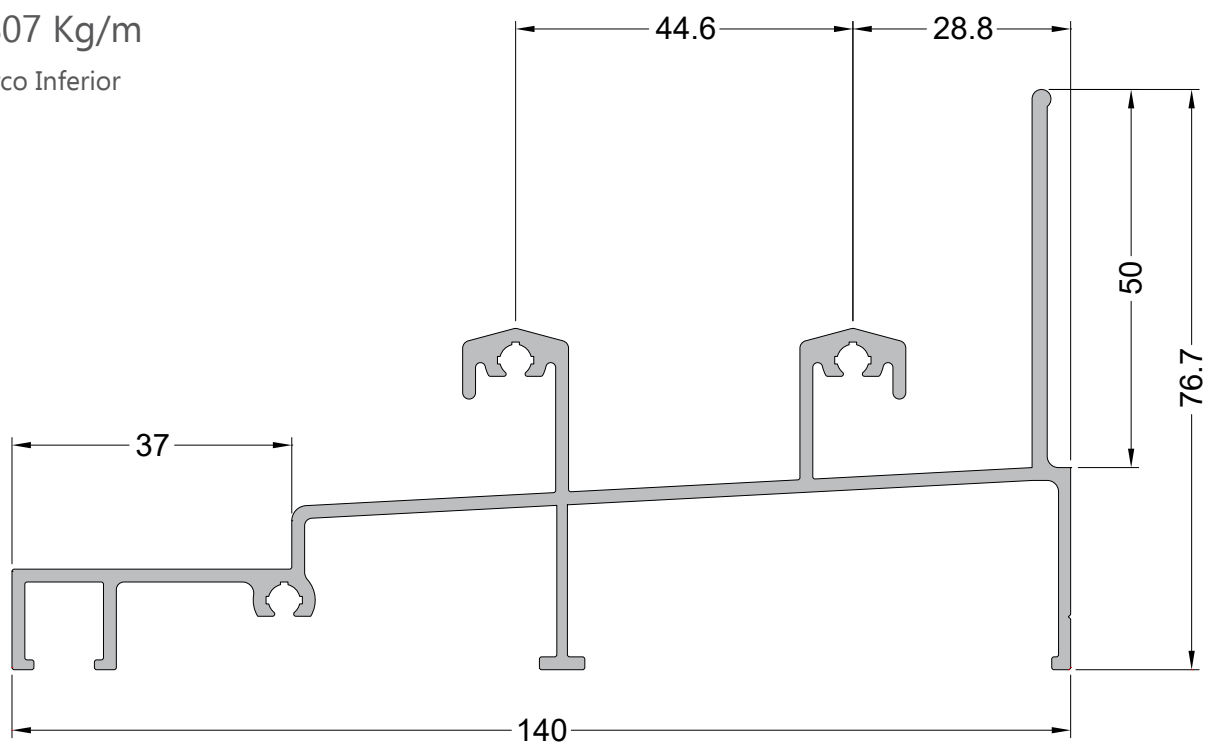

### ALG-940 (MN-049)

1.312 Kg/m

Marco Intermediário

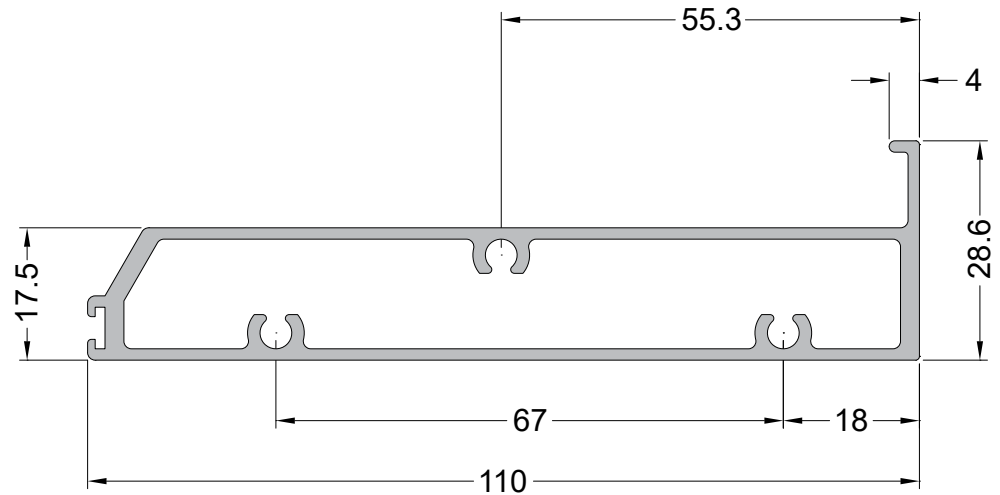

### ALG-200

0,623 Kg/m

Marco Intermediário

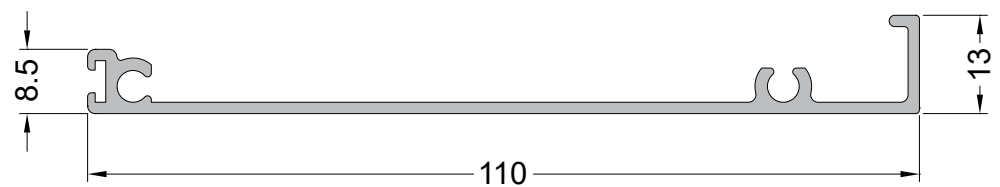

### MN-003

1.091 Kg/m

Marco

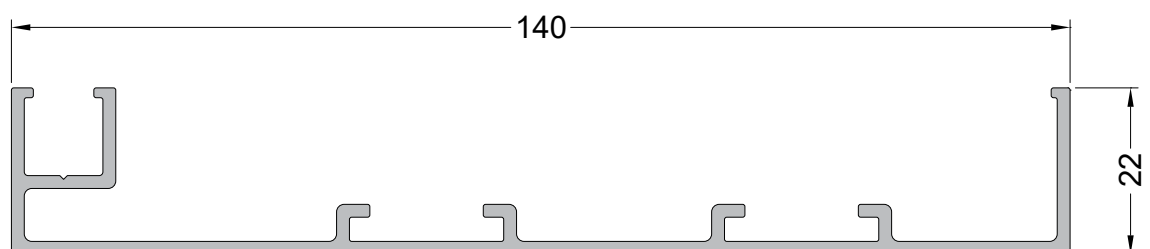

ALG-130  
1,463 Kg/m  
Tampa Interna

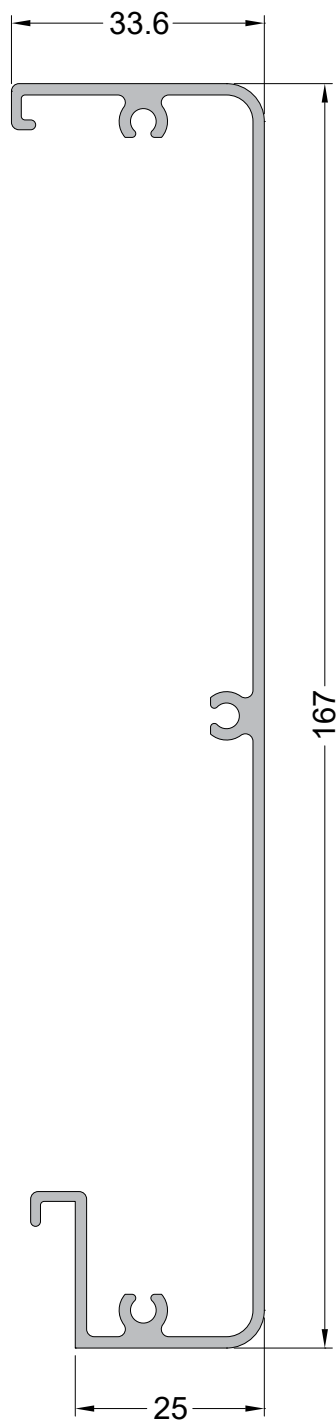

ALG-230  
1,720 Kg/m  
Tampa Interna

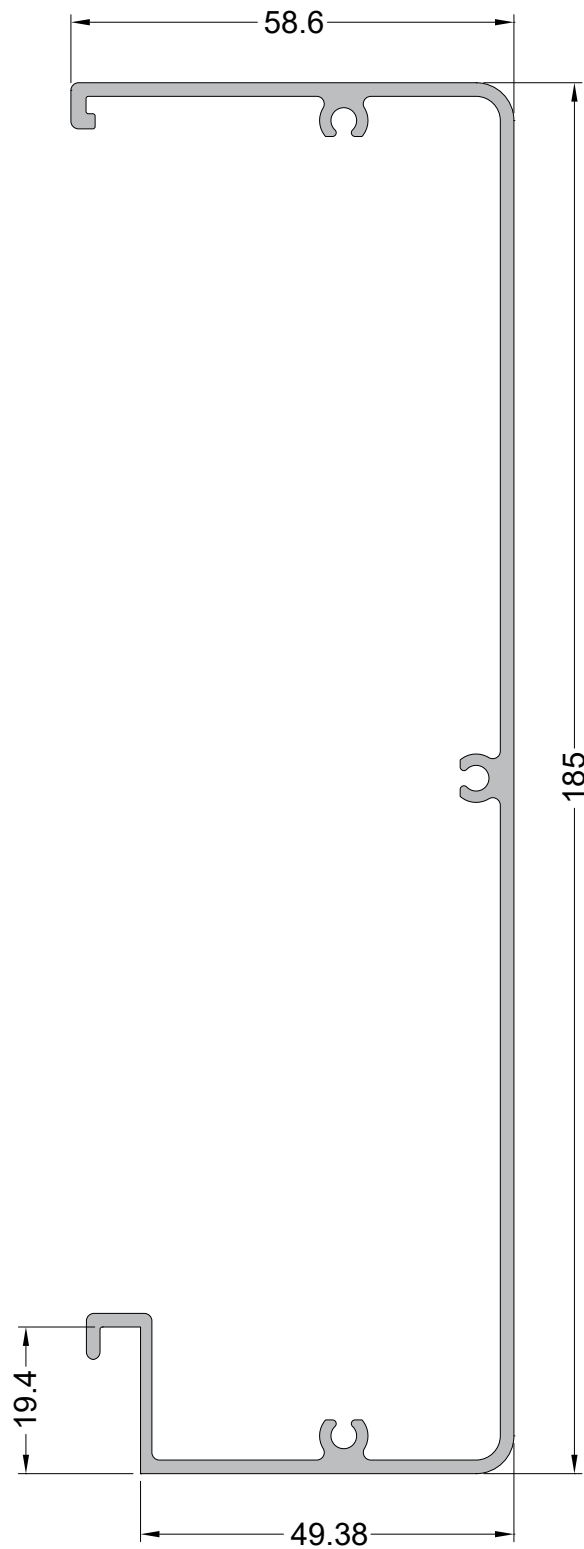

MN-039  
1.348 Kg/m  
Tampa Externa

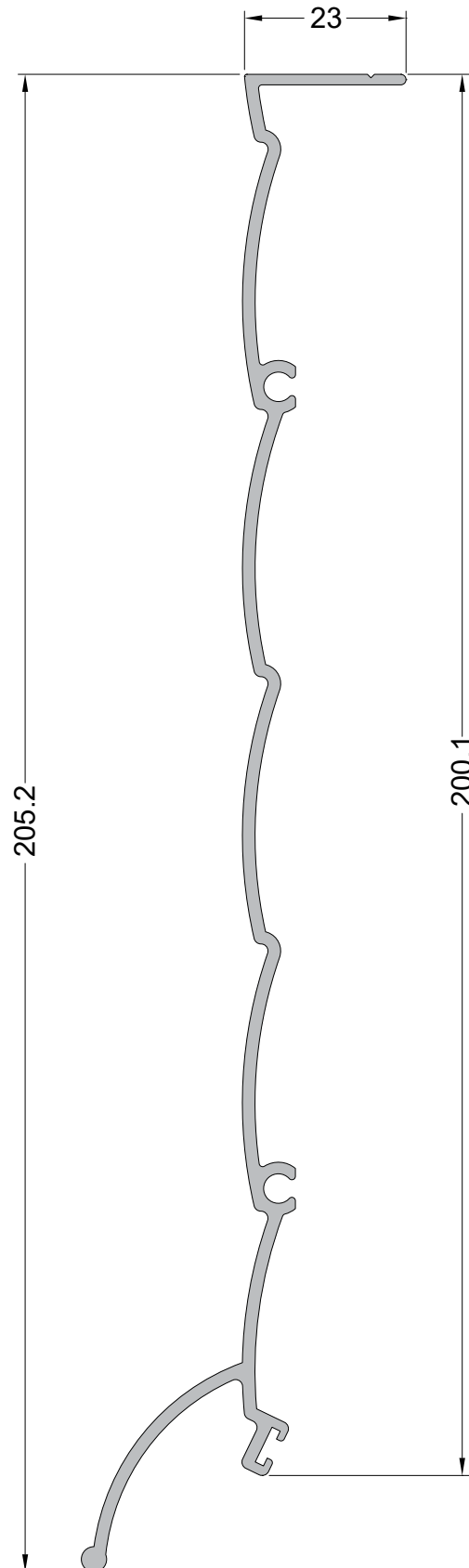

MN-050

0.738 Kg/m

Caixa do Recolhedor

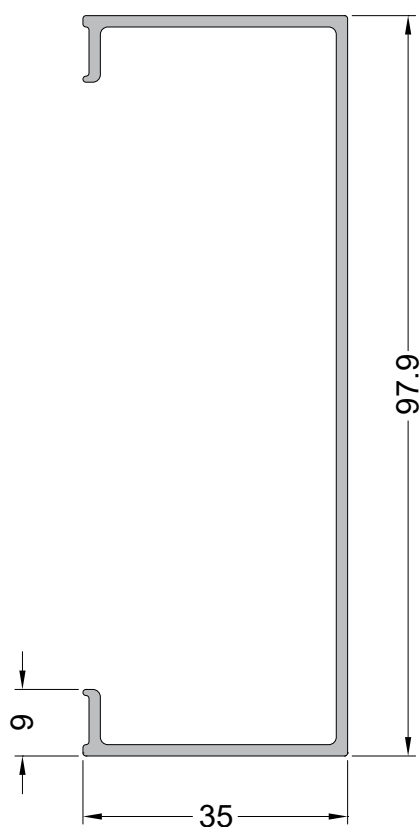

ALG-510 (MN-015)

0.843 Kg/m

Tubo Recolhedor

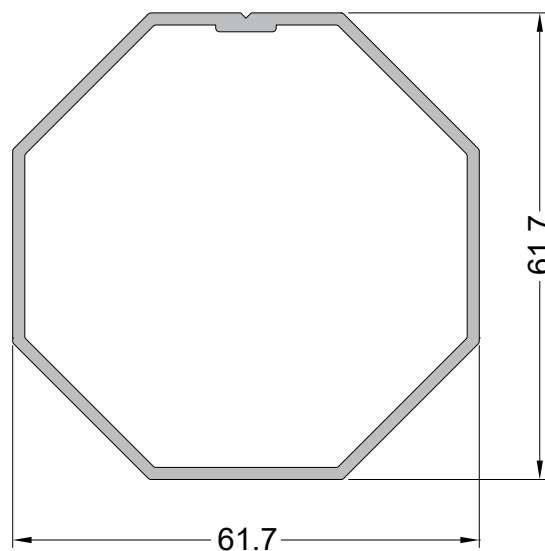

MN-004

0.176 Kg/m

Remate

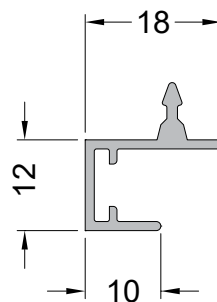

MN-007

0.710 Kg/m

Guia Persiana

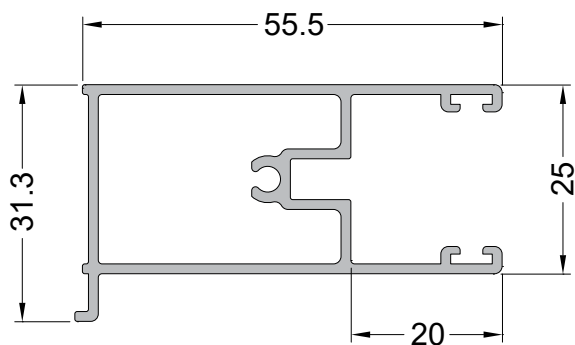

MN-055

0.376 Kg/m

Terminal

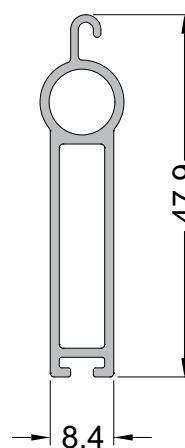

ALG-3006  
0,650 Kg/m  
Travessa Folha

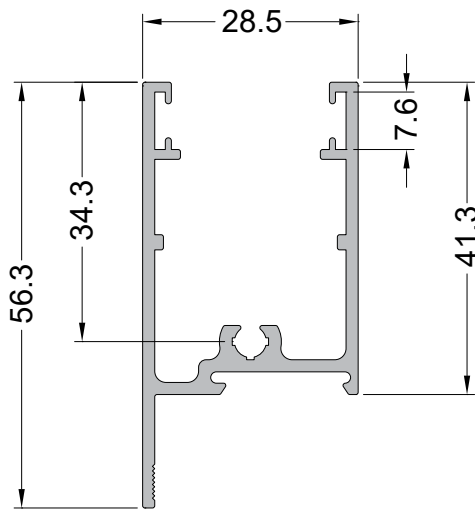

ALG-3317  
0,756 Kg/m  
Travessa Central Folha

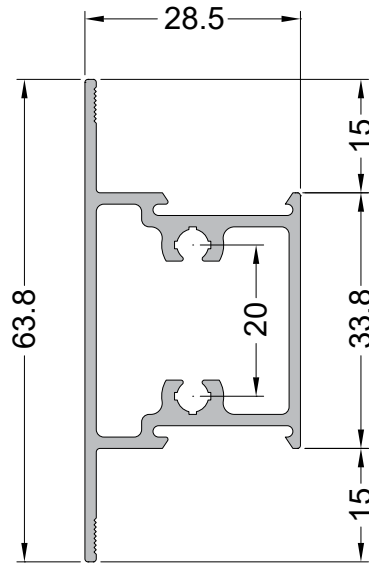

ALG-3007  
1,163 Kg/m  
Travessa Inferior Folha

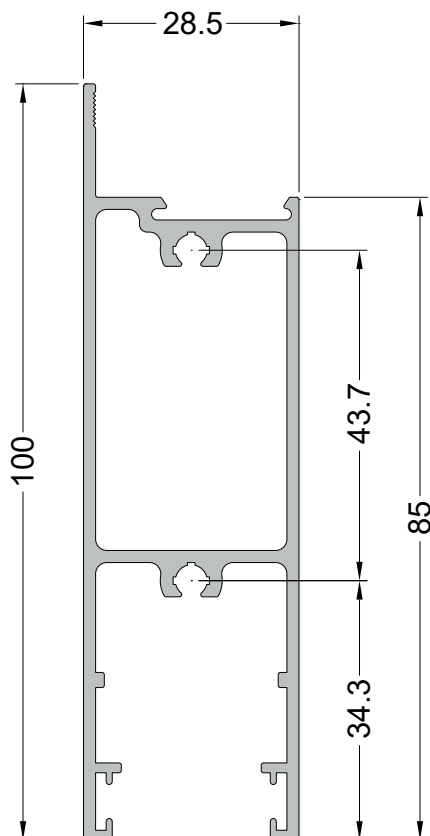



ALG-20401

1,370 Kg/m

Travessa Central Folha

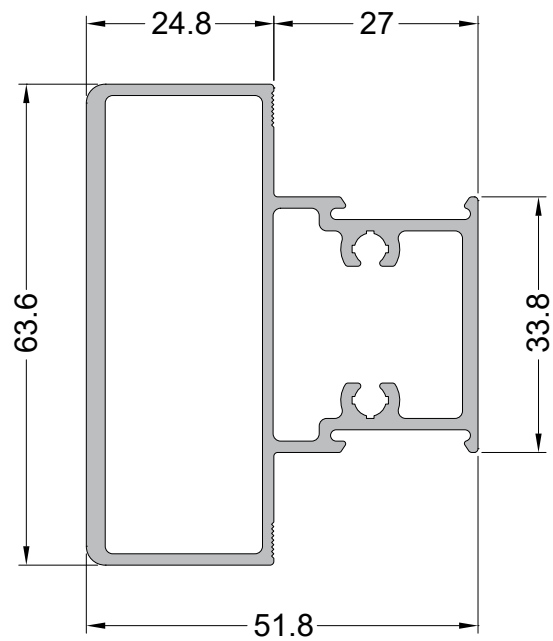

ALG-20402

1,540 Kg/m

Travessa Central Folha

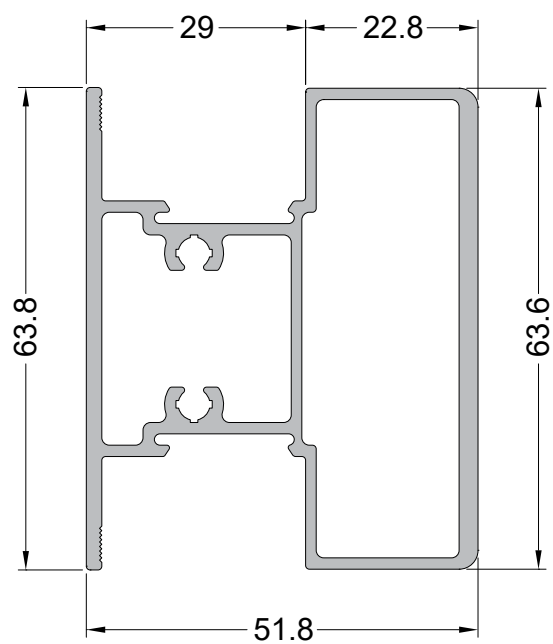

ALG-3049

0,873 Kg/m

Montante Mão de Amigo

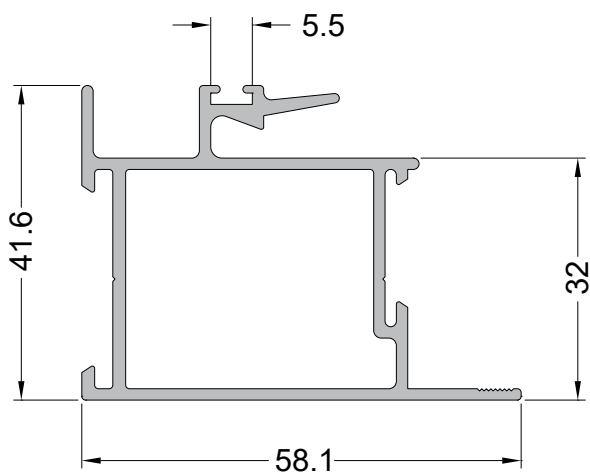

ALG-3048

0,909 Kg/m

Montante Mão de Amigo

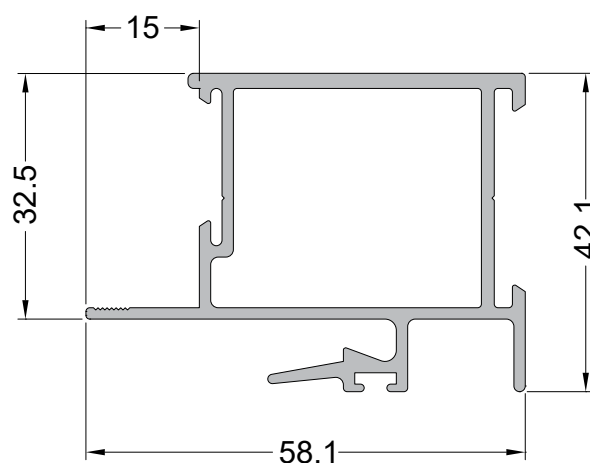

ALG-3311

0,795 Kg/m

Montante Lateral

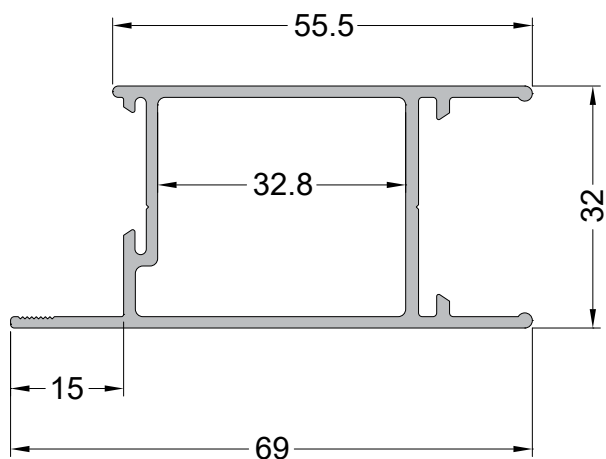

ALG-710

1,081 Kg/m

Montante Lateral

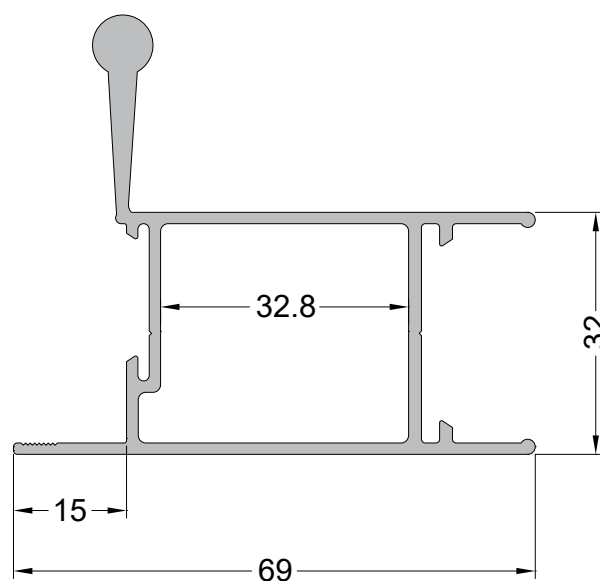

ALG-40304  
1,194 Kg/m  
Montante Lateral

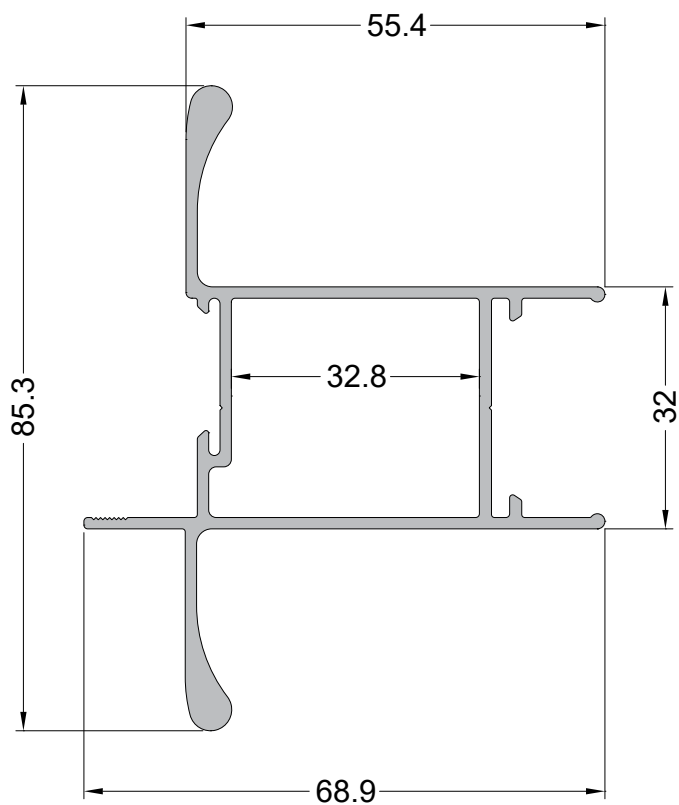

ALG-3017  
1,212 Kg/m  
Montante Central

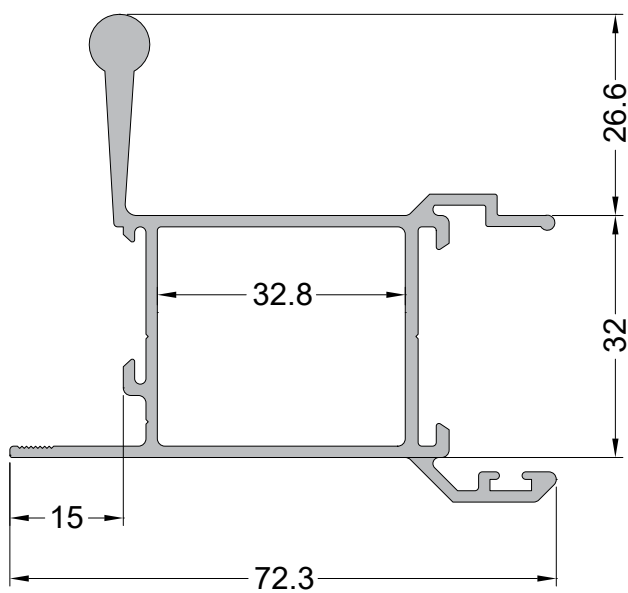

ALG-3020  
1,177 Kg/m  
Montante Central

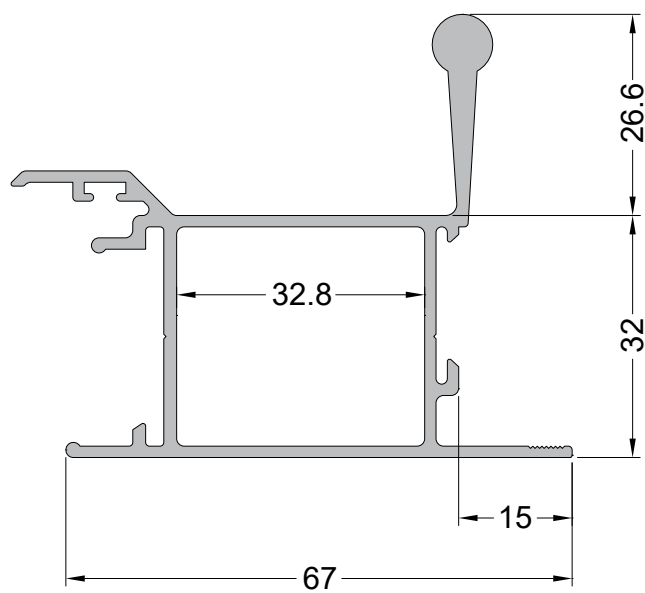

ALG-3050  
0,927 Kg/m  
Montante Central

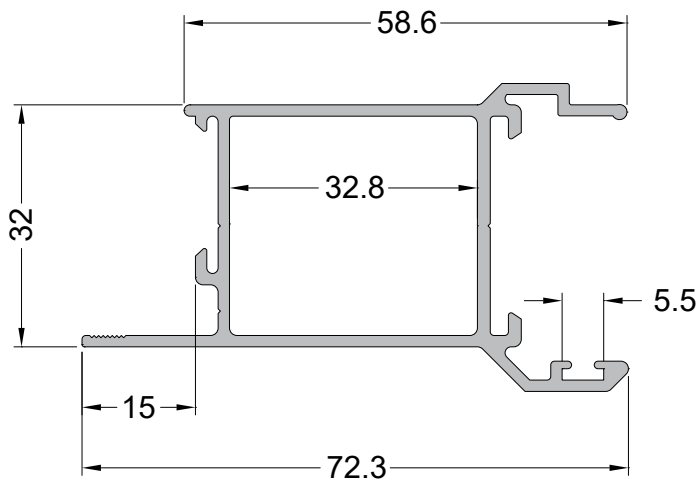

ALG-3051  
0,906 Kg/m  
Montante Central

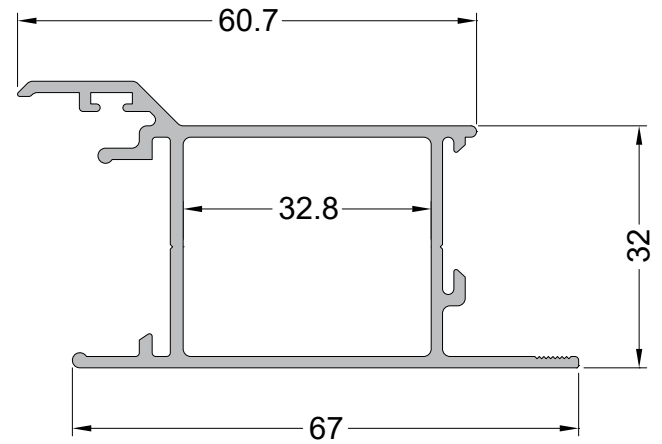

ALG-4051  
0.900 kg/m  
Montante Central

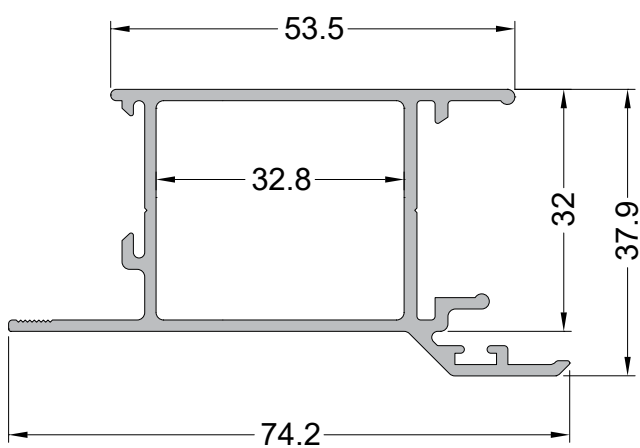

CX-3095  
0,895 Kg/m  
Montante Central

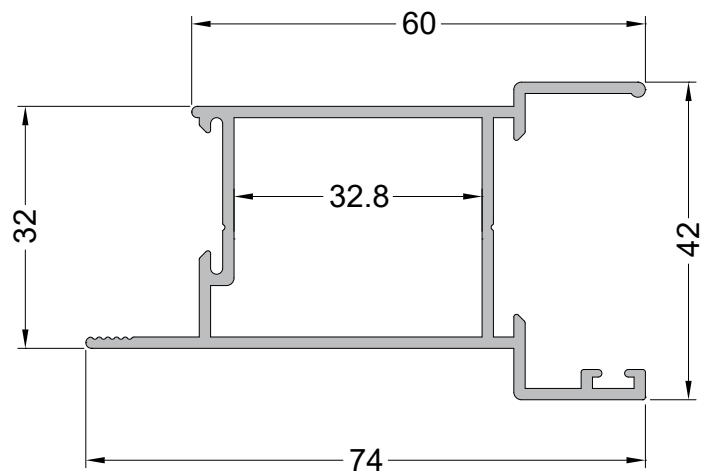

CX-323  
1,577 Kg/m  
Montante Central

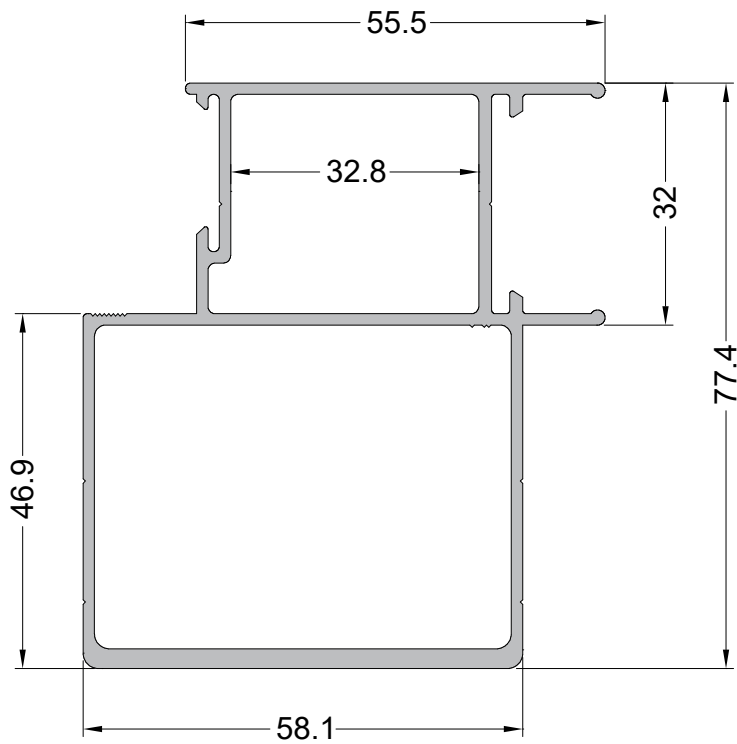

CX-321  
1,686 Kg/m  
Montante Central

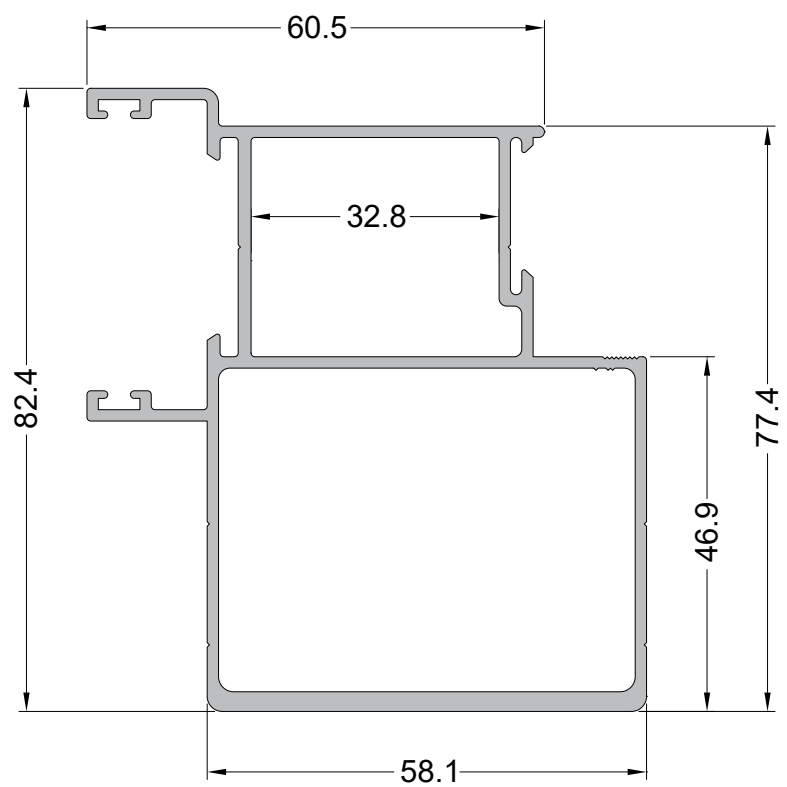

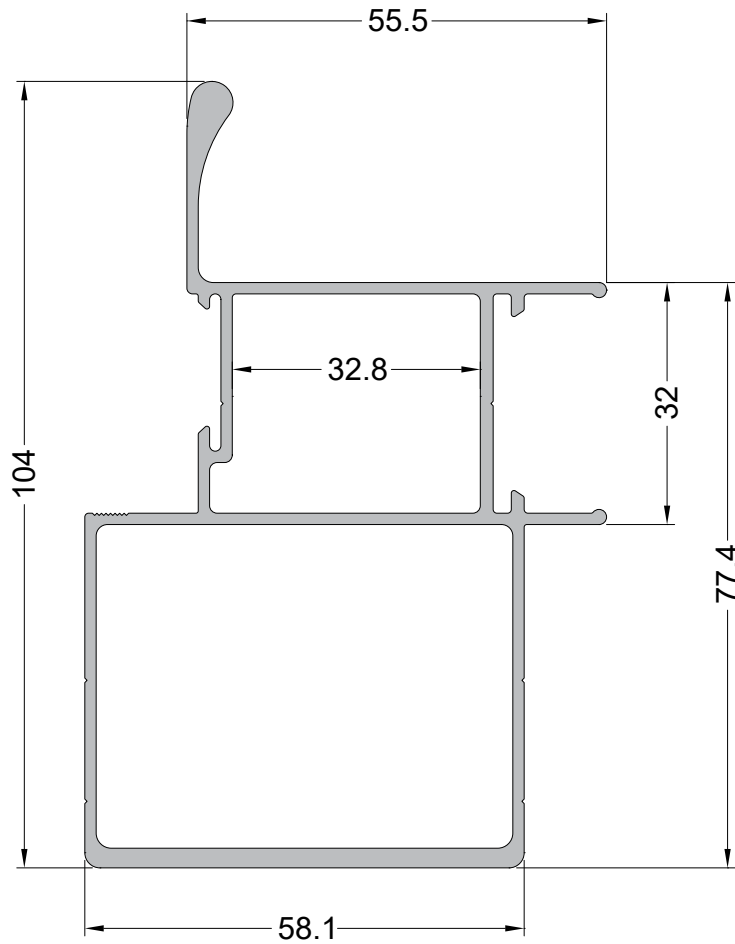

ALG-40303  
1,768 Kg/m  
Montante Central

ALG-40302  
1,843 Kg/m  
Montante Central

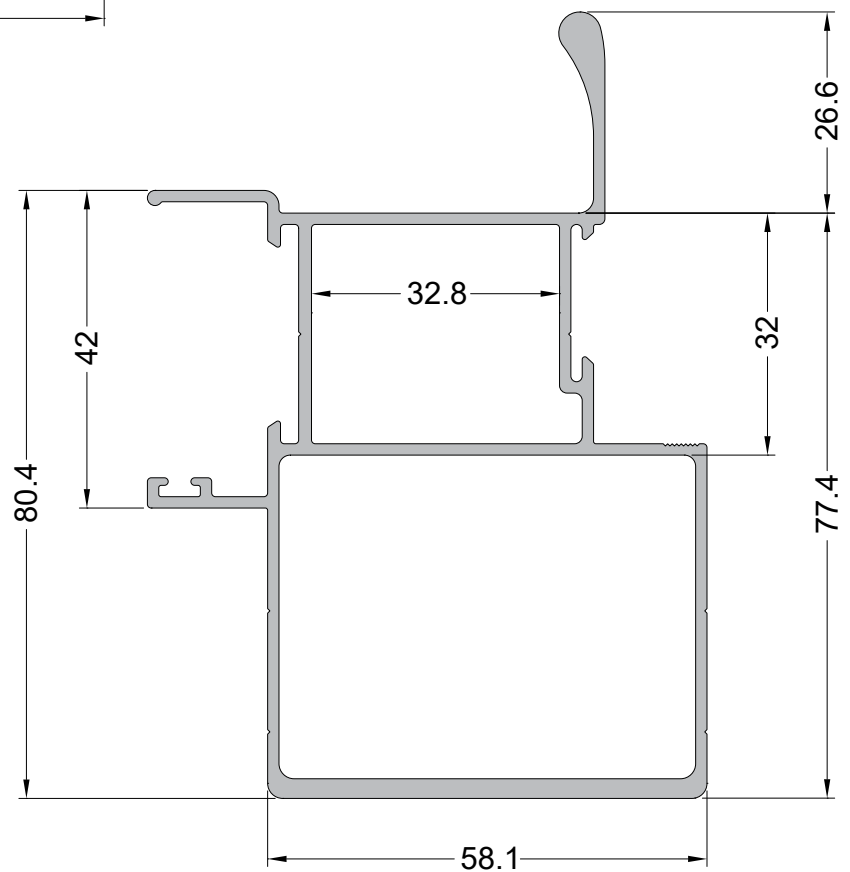

ALG-3015  
1,725 Kg/m  
Montante Central

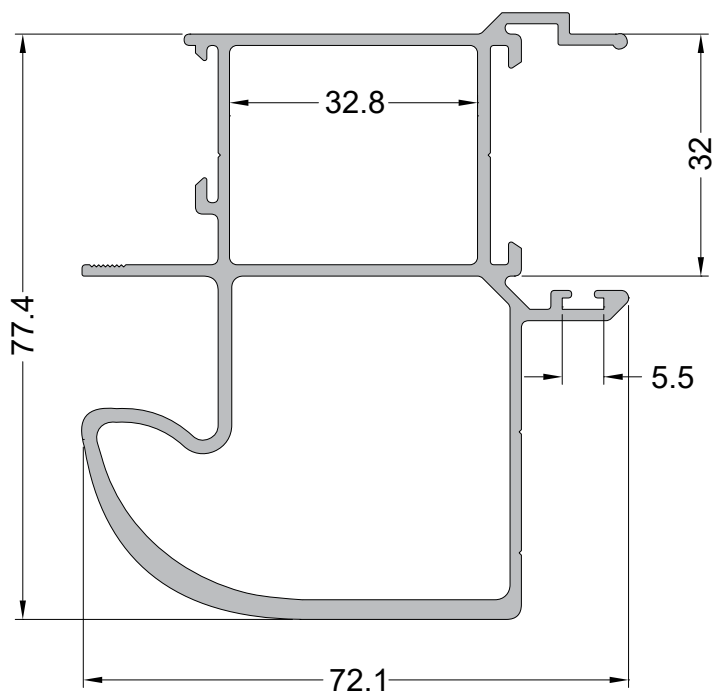

ALG-3014  
1,726 Kg/m  
Montante Central

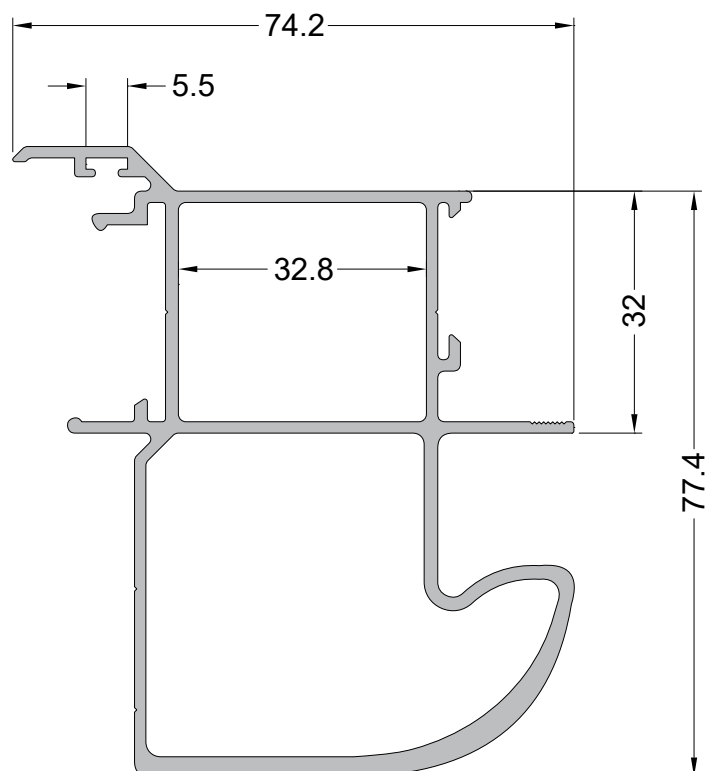

ALG-4015  
1,780 Kg/m  
Montante Central

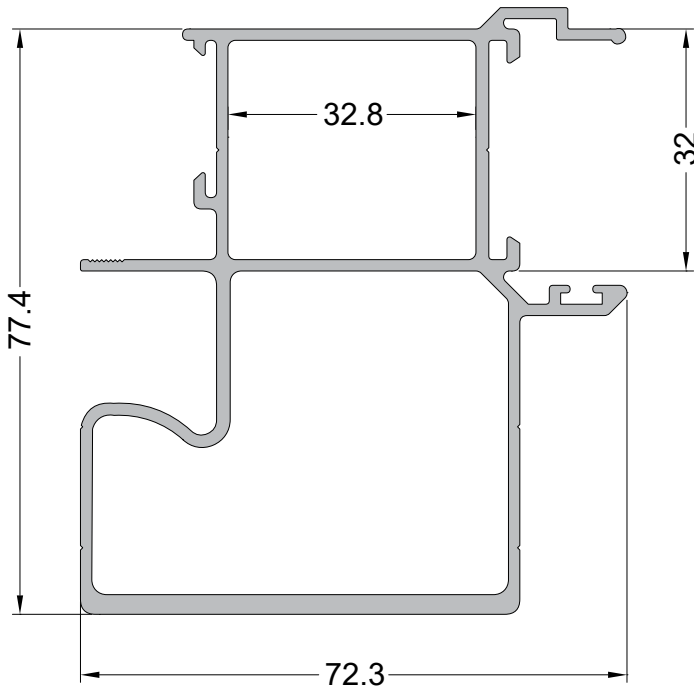

ALG-4014  
1.782 kg/m  
Montante Central

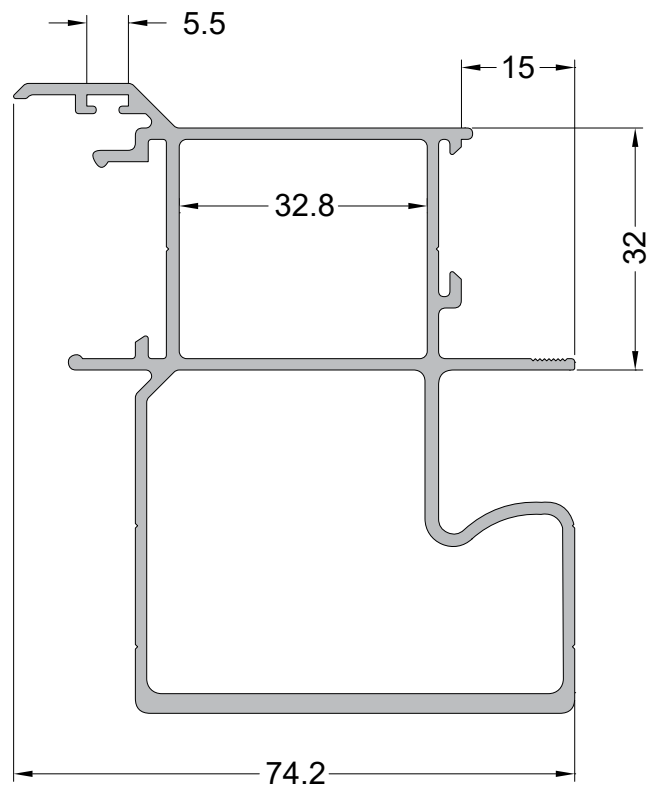



CX-337 (ALG-4021)

1,720 Kg/m

Montante Mão de Amigo

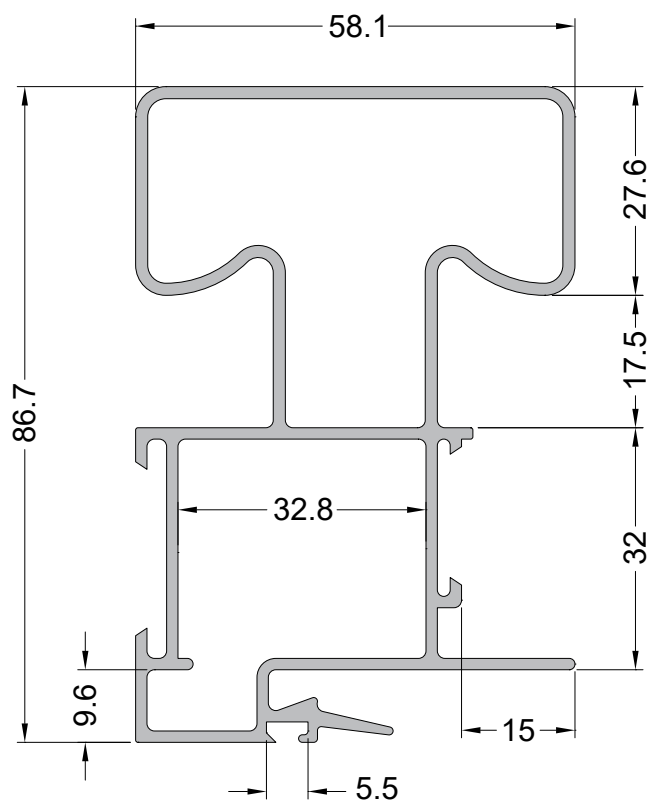

ALG-4052

1.780 kg/m

Montante Mão de Amigo

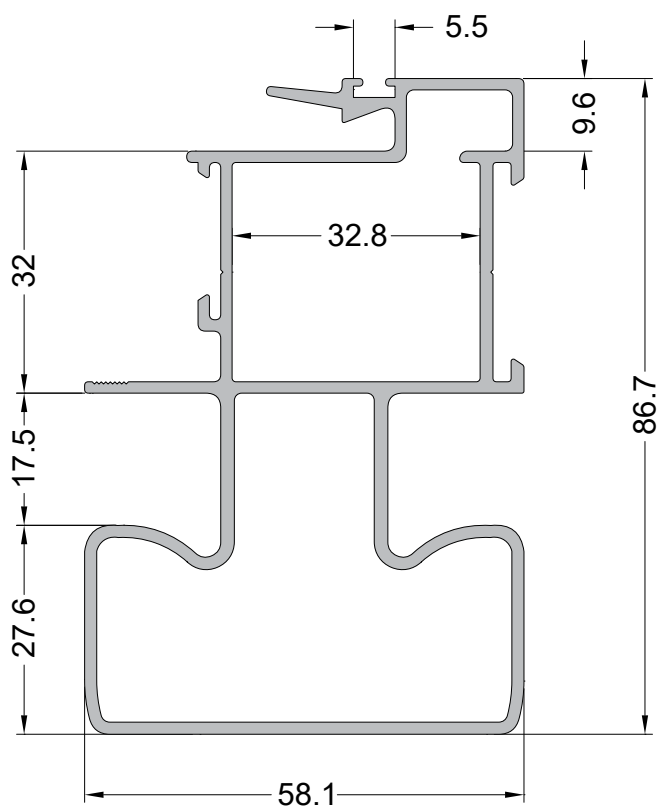

ALG-5052  
2,299 Kg/m  
Montante Mão de Amigo

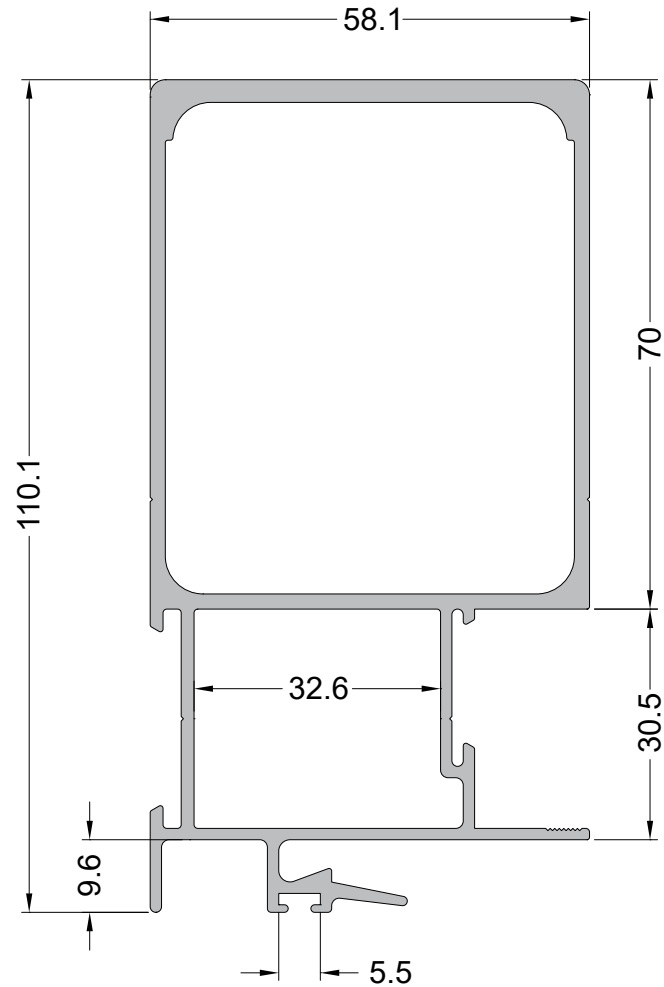

ALG-40402  
1,518 Kg/m  
Montante Mão de Amigo

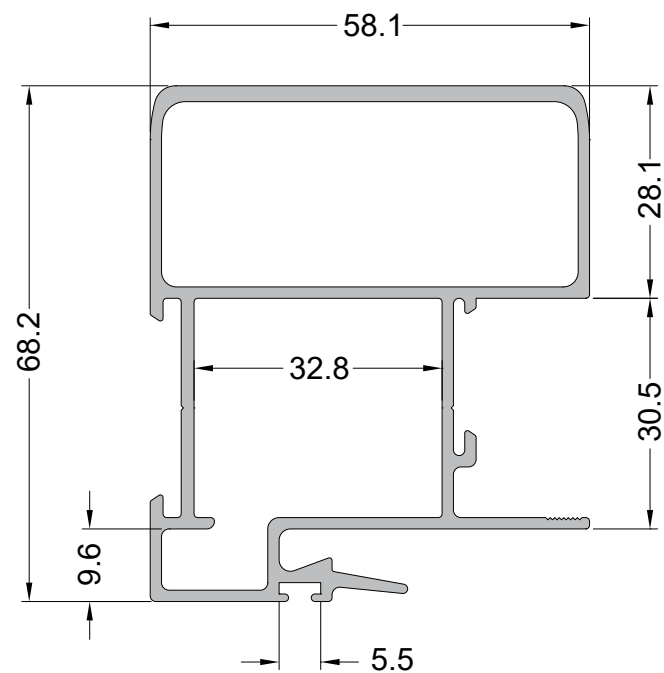

CX-336 (ALG-3021)

1,724 Kg/m

Montante Mão de Amigo

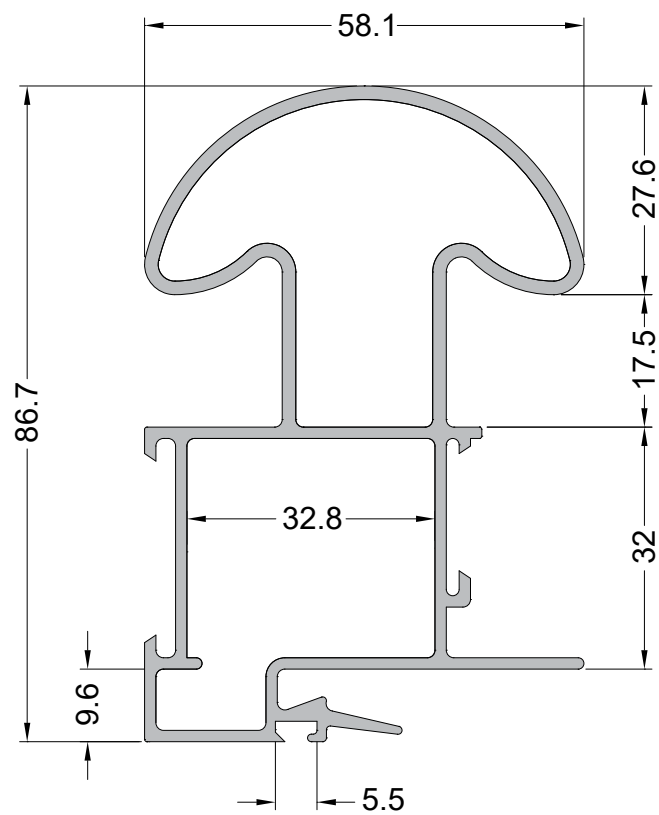

ALG-3052

1.698 kg/m

Montante Mão de Amigo

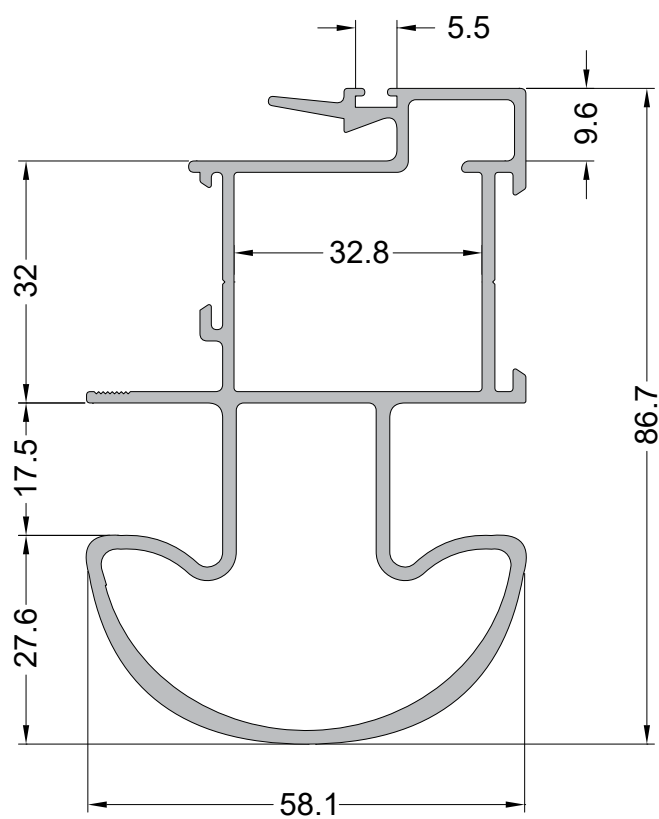

SI-313

1,666 Kg/m

Montante Mão de Amigo

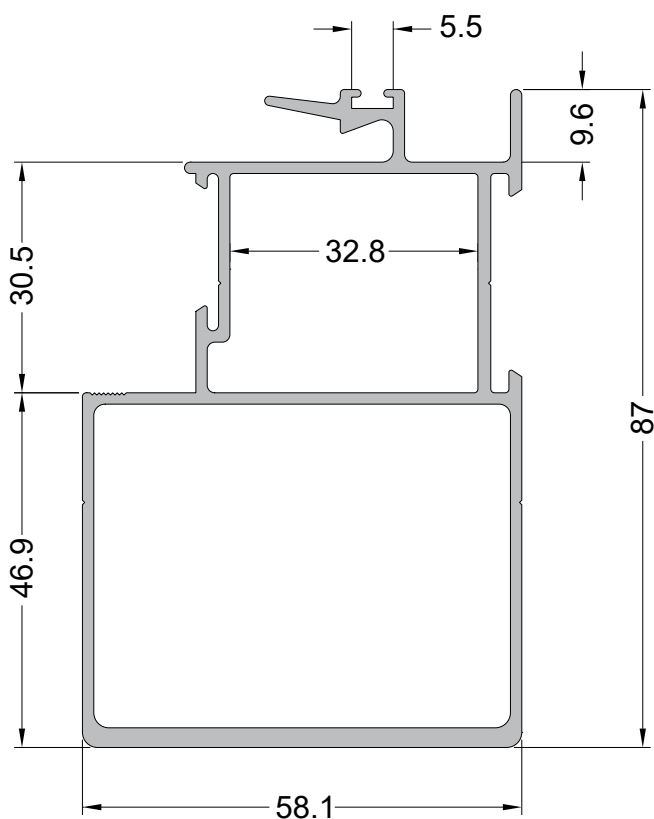

ALG-3141

0,834 Kg/m

Montante

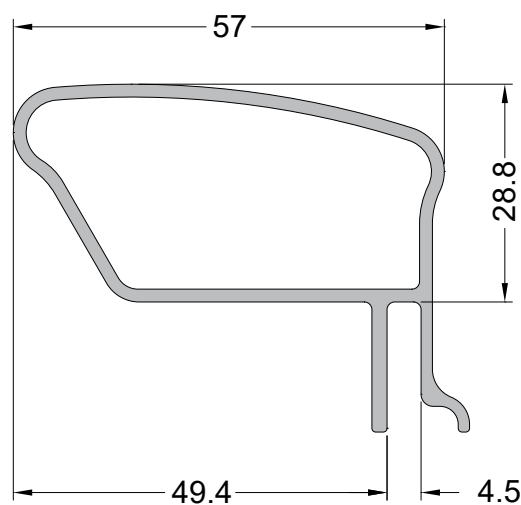

ALG-4028

0,433 Kg/m

Mata-Junta

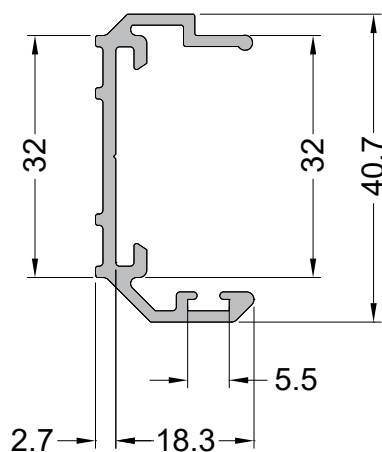

ALG-3142

0,413 Kg/m

Complemento

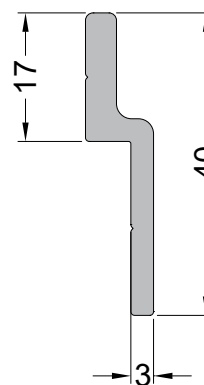

ALG-3056  
0,659 Kg/m  
Marco

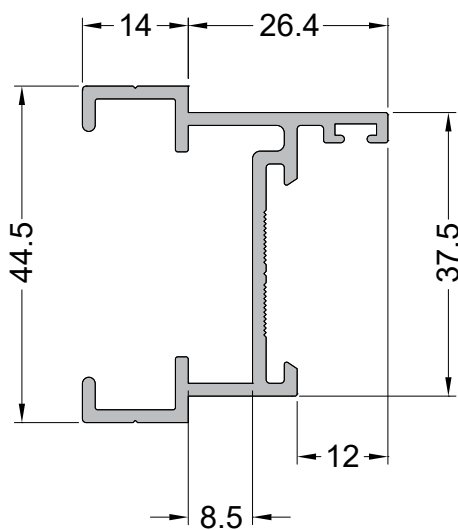

ALG-3058  
0,744 Kg/m  
Travessa Folha

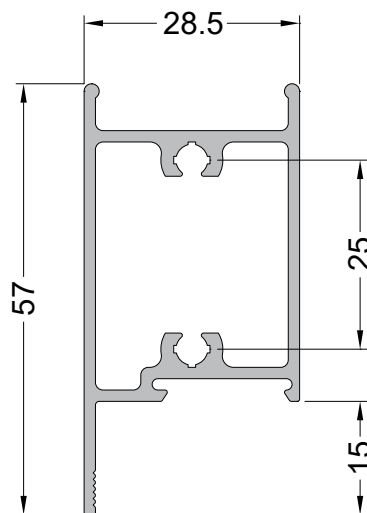

ALG-3042  
1,099 Kg/m  
Folha

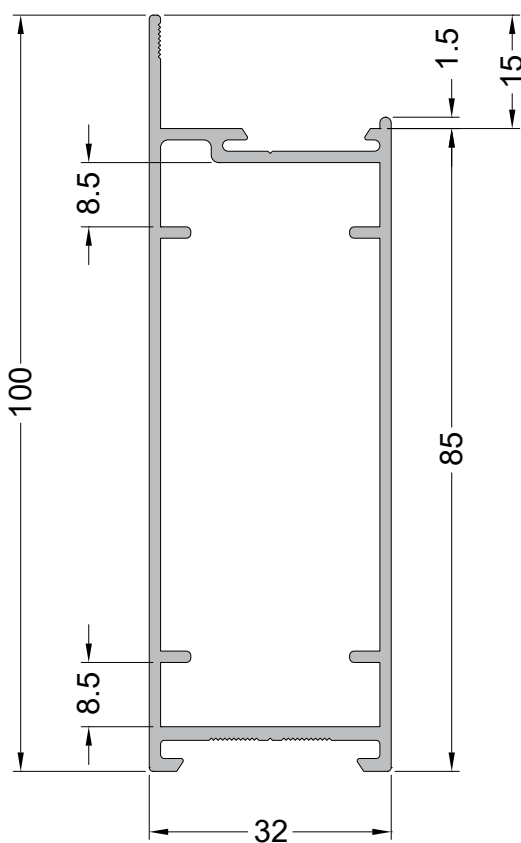

ALG-3043  
0,807 Kg/m  
Folha

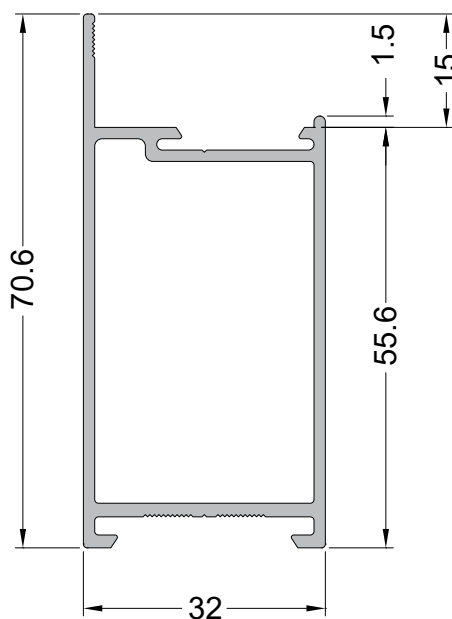

ALG-3016  
0,341 Kg/m  
Mata-Junta

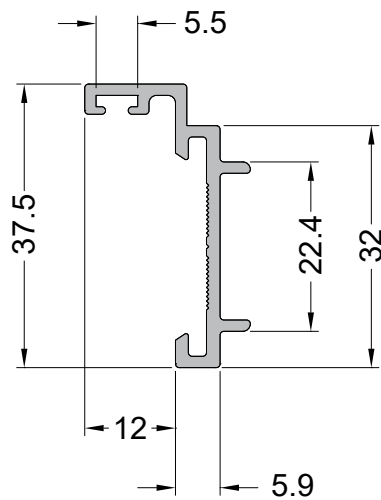

CX-322 (ALG-3346)  
0,550 Kg/m  
Marco

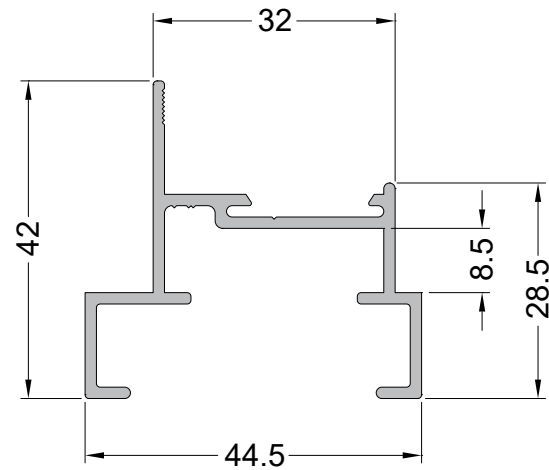

ALG-3023  
0,769 Kg/m  
Mata-Junta Porta Embutida

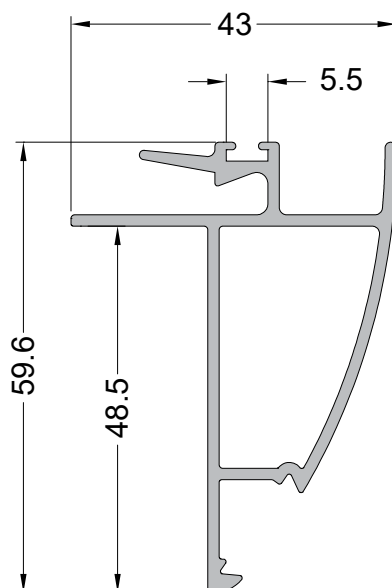

CX-504 (ALG-3057)

0,168 Kg/m

Baguete

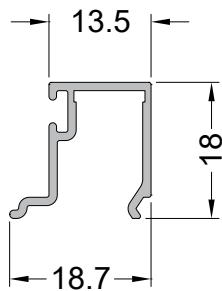

CX-3096

0.148 Kg/m

Baguete

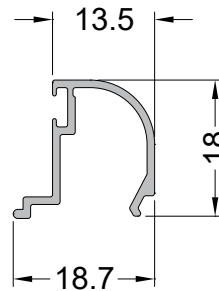

ALG-3328

0,172 Kg/m

Baguete

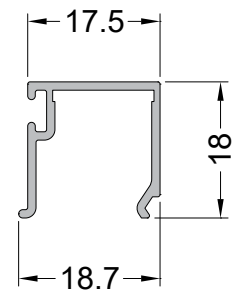

ALG-5015

0,143 Kg/m

Baguete

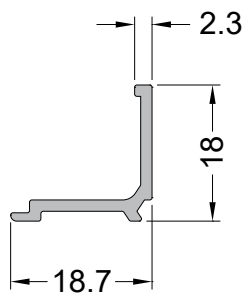

ALG-3027

0,140 Kg/m

Baguete

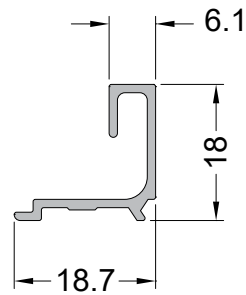

ALG-3070  
0,552 Kg/m  
Folha Max

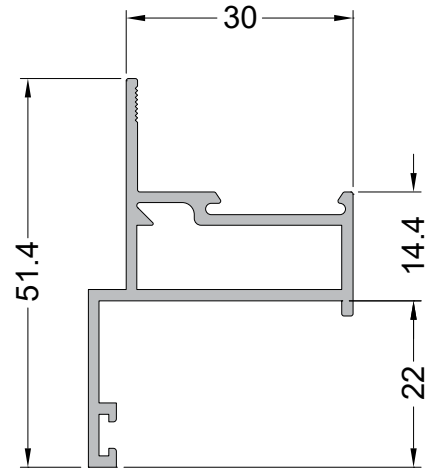

ALG-3071  
0,413 Kg/m  
Folha Max

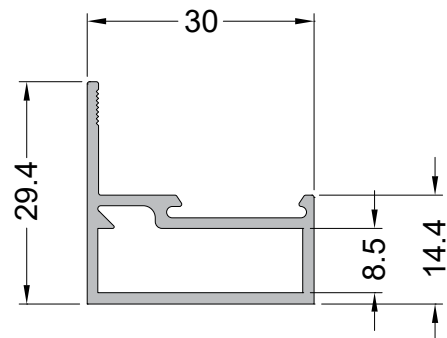

ALG-3072  
0,279 Kg/m  
Inversor

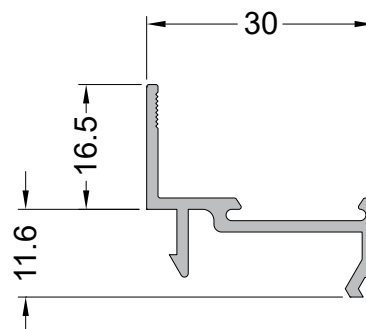



RE-01602  
0,992 kg/m  
Marco

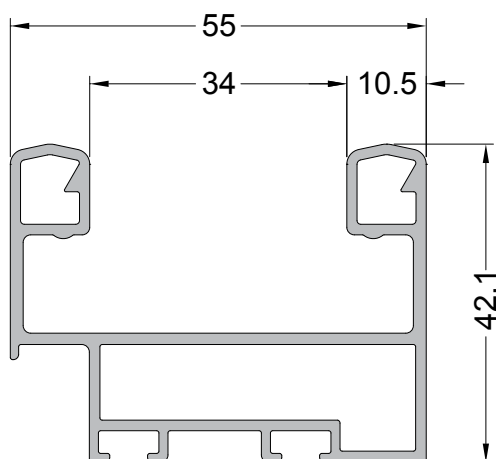

RE-01601  
1,612 kg/m  
Marco

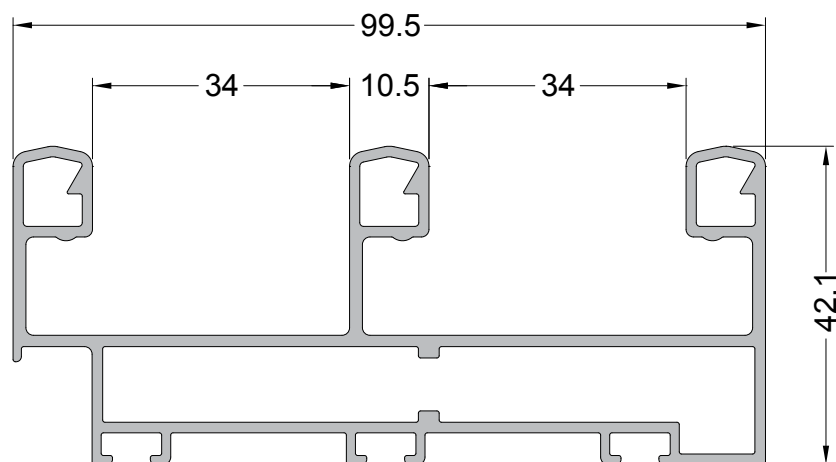

RE-01603  
1,231 kg/m  
Marco

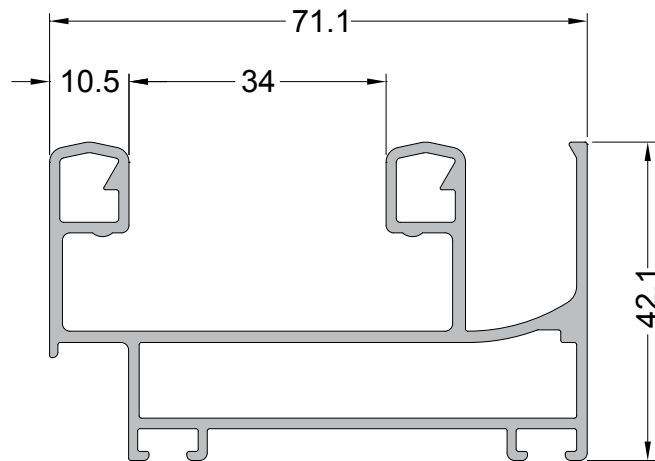

RE-01604  
1,849 kg/m  
Marco

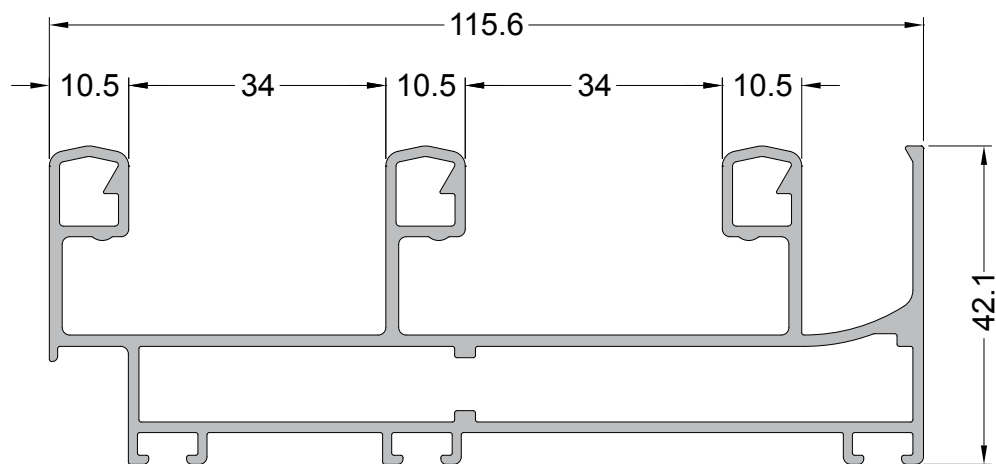

RE-01605  
1,339 kg/m  
Marco

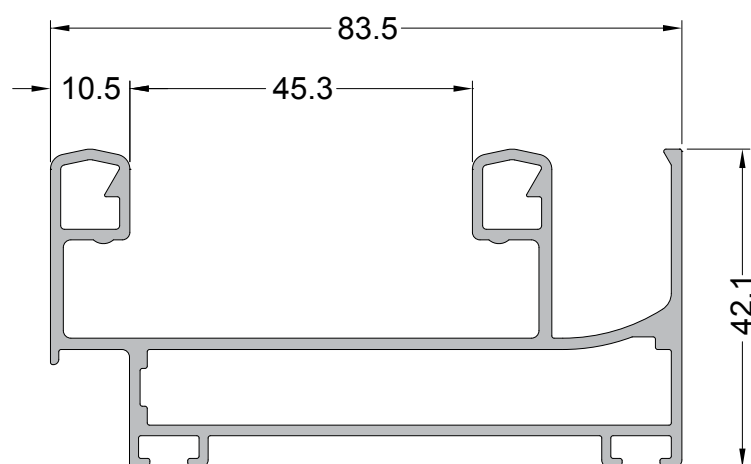

RE-01101  
1,141 kg/m  
Marco

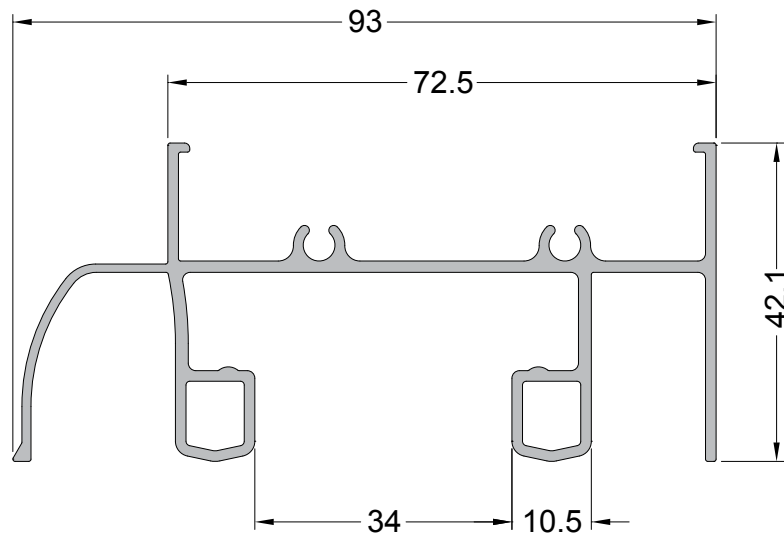

RE-01001  
1,122 kg/m  
Marco

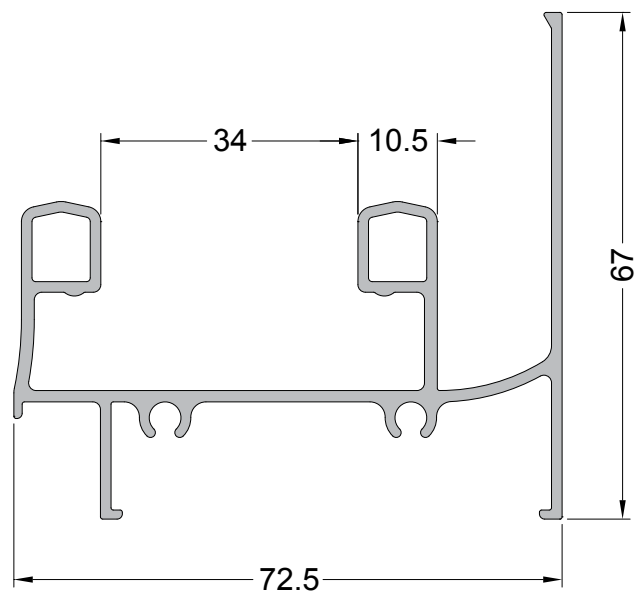

RE-01104  
1,486 kg/m  
Marco

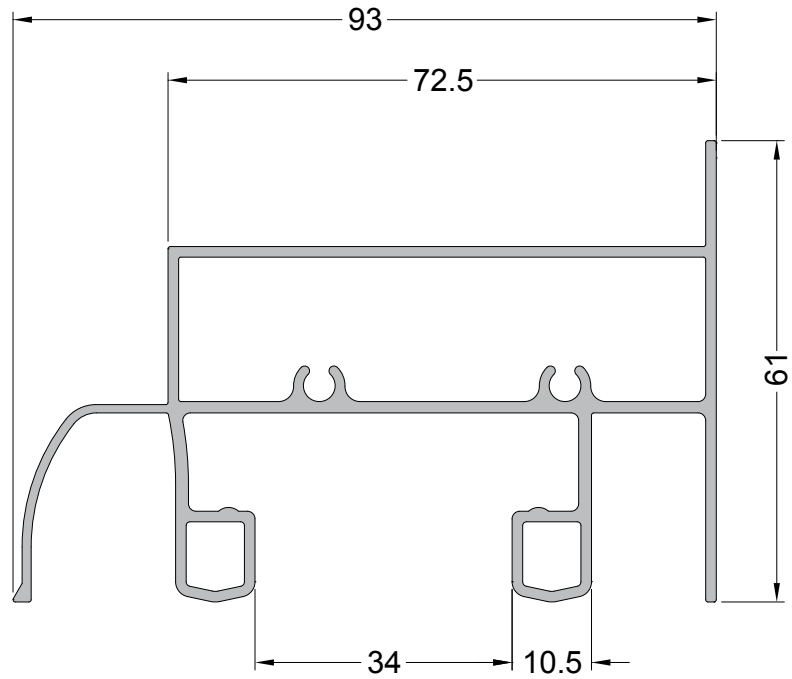

RE-01004  
1,494 kg/m  
Marco

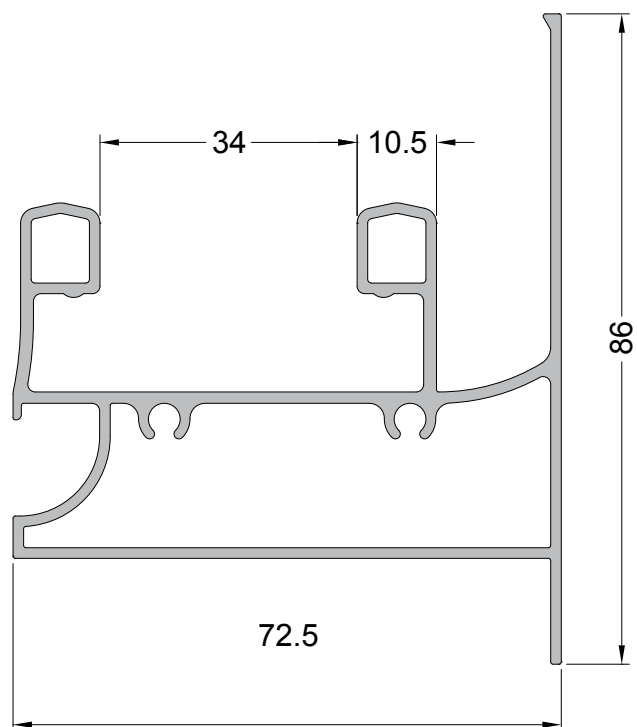

RE-01102  
1,527 kg/m  
Marco

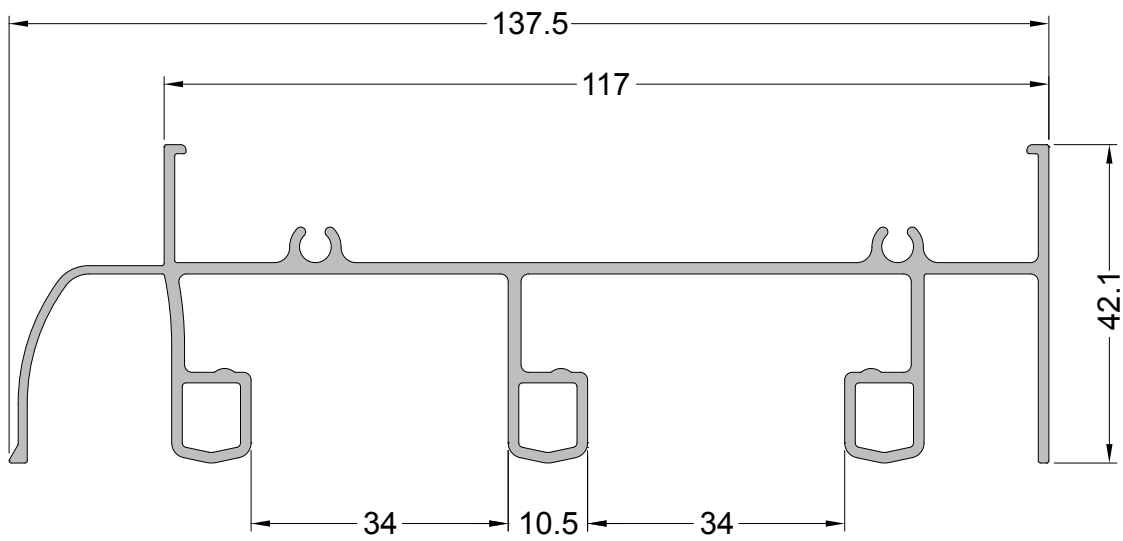

RE-01002  
1,508 kg/m  
Marco

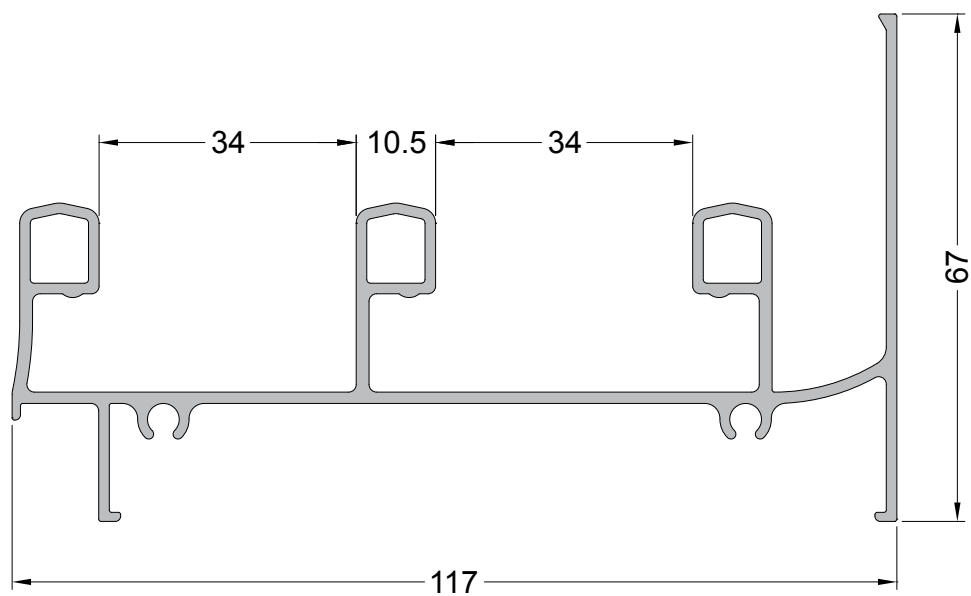

RE-01103  
2,041 kg/m  
Marco

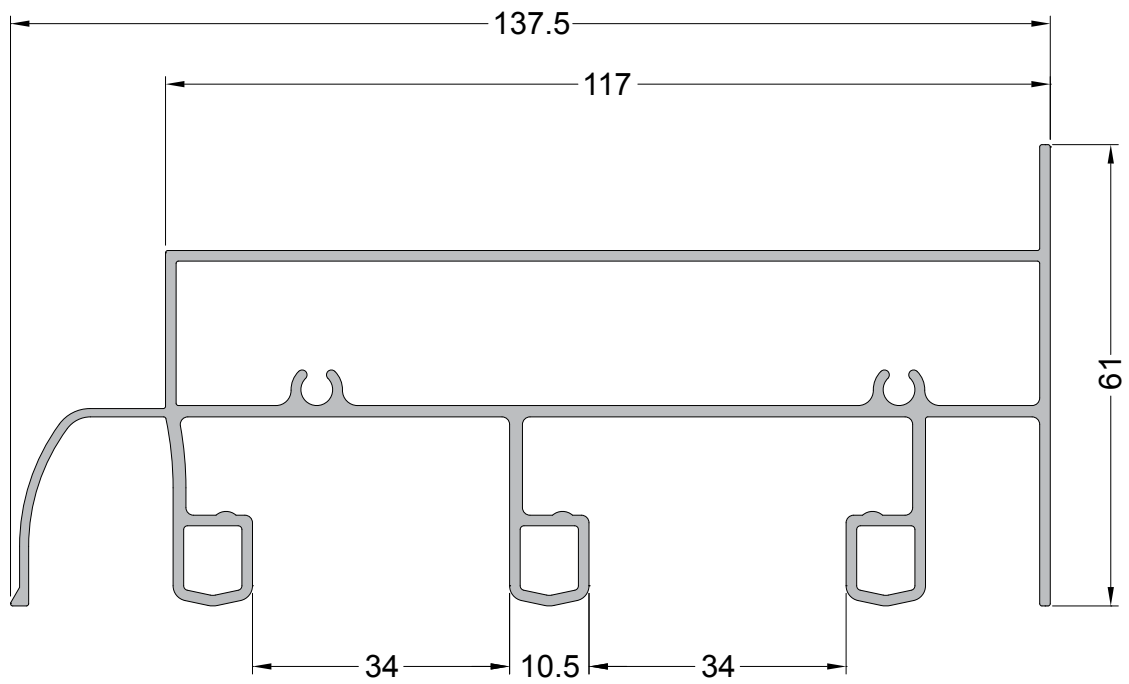

RE-01003  
2,048 kg/m  
Marco

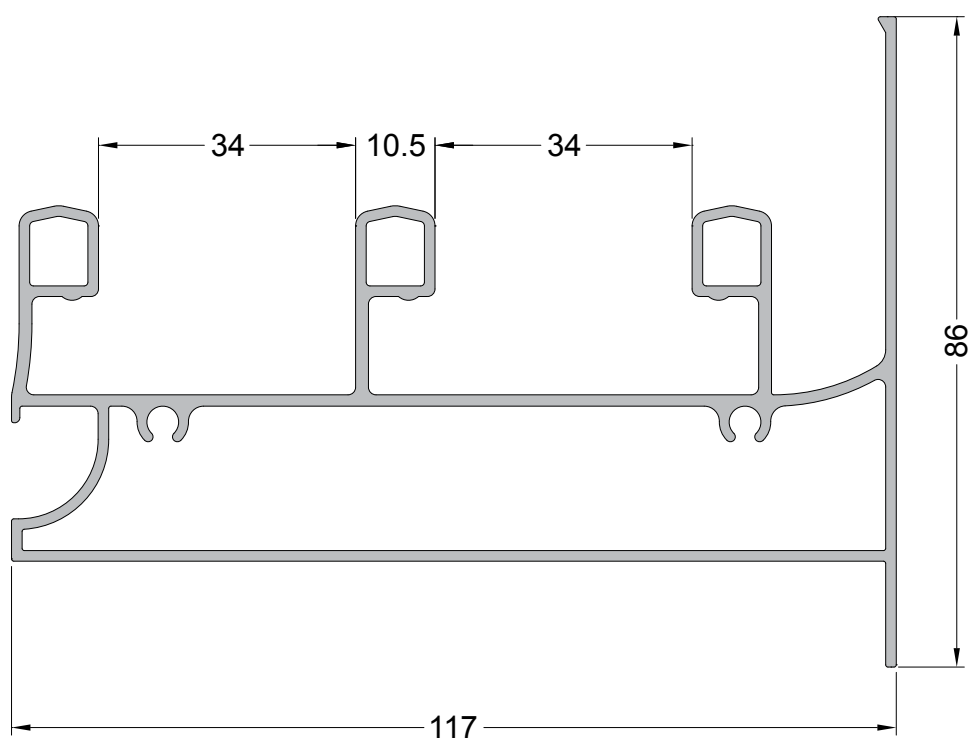

RE-01304  
0,509 kg/m  
Marco

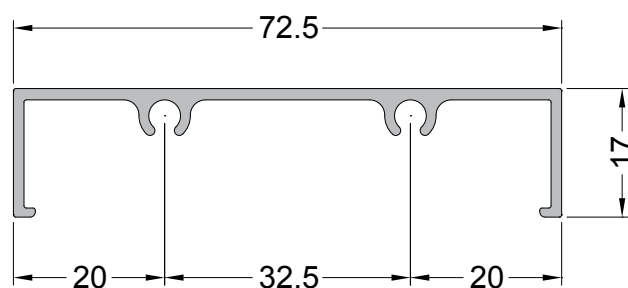

RE-01303  
0,689 kg/m  
Marco

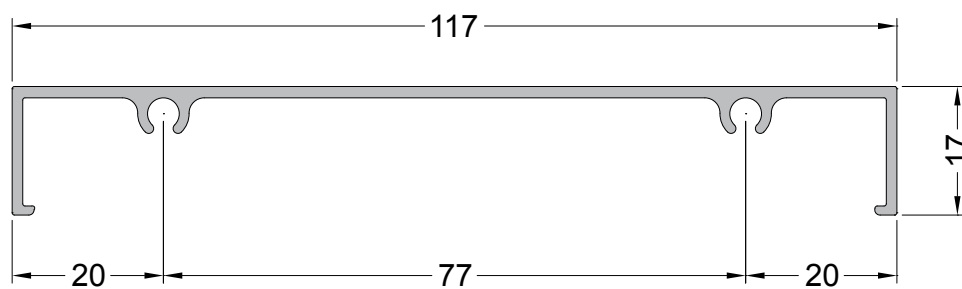



RE-01301  
0,421 kg/m  
Marco

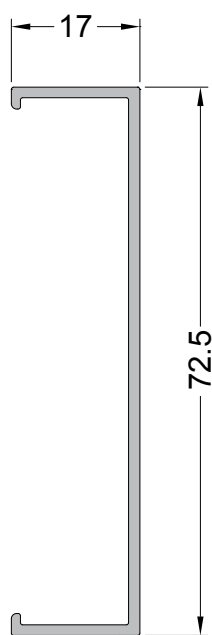

RE-01302  
0,602 kg/m  
Marco

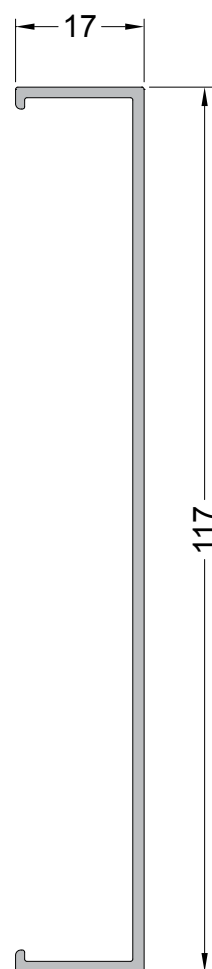

RE-20201  
0,730 kg/m  
Travessa

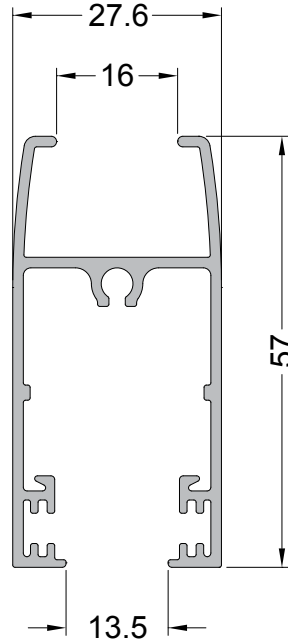

RE-20001  
1.200 kg/m  
Travessa

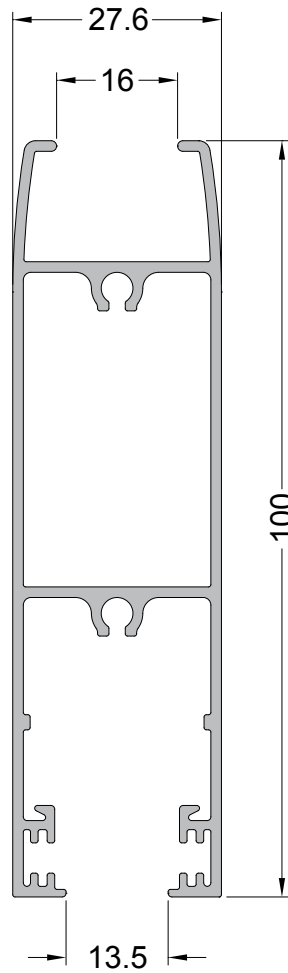

RE-20202  
0,884 kg/m  
Travessa

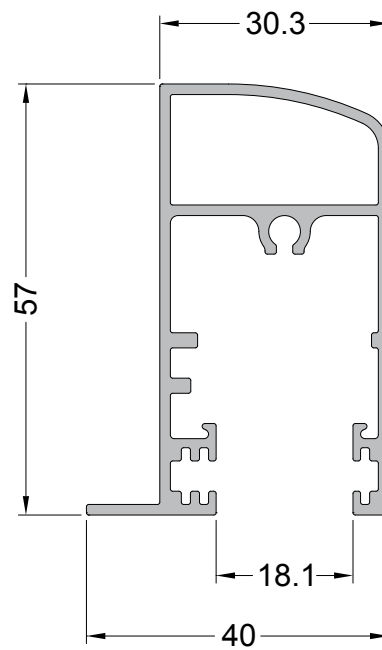

RE-20002  
1,155 kg/m  
Travessa

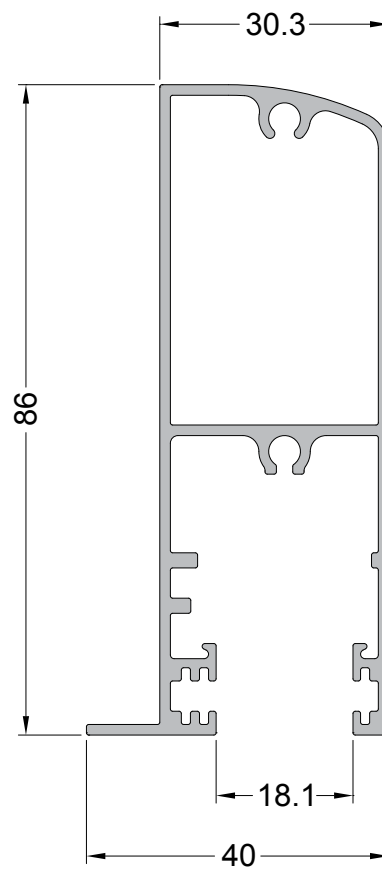

RE-20401  
1,054 kg/m  
Travessa

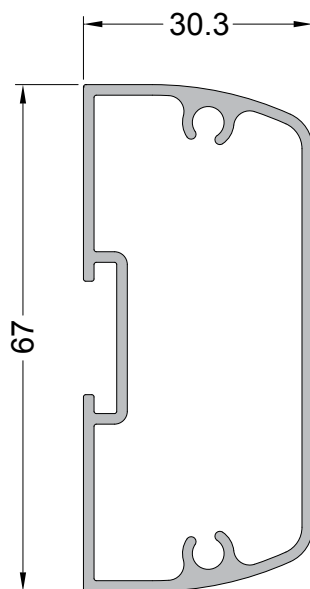

RE-40301  
0,822 kg/m  
Montante

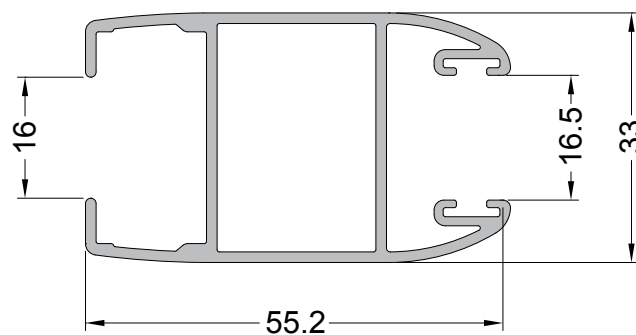

RE-40302  
1,051 kg/m  
Montante

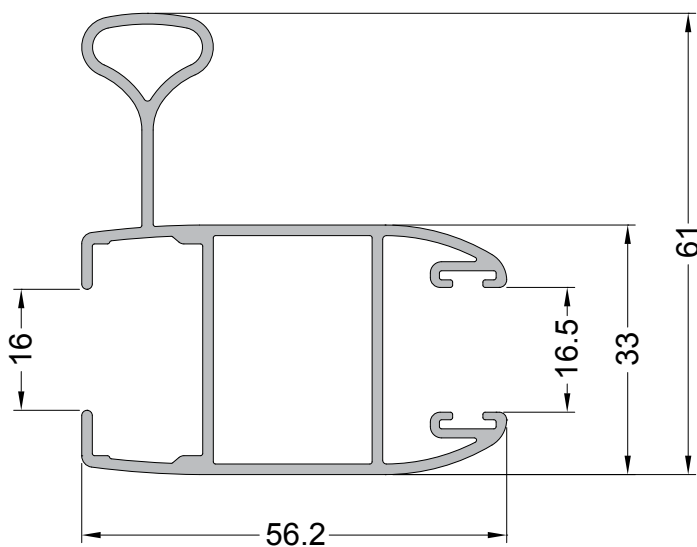

RE-40401  
0,722 kg/m  
Montante

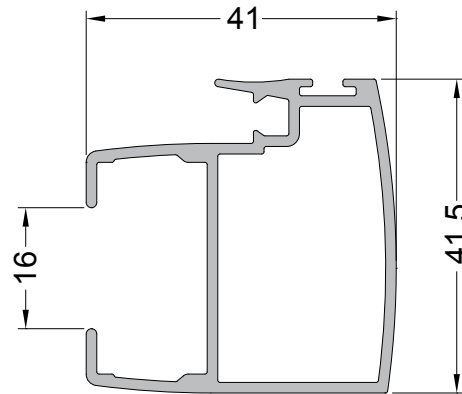

RE-40303  
1,047 kg/m  
Montante

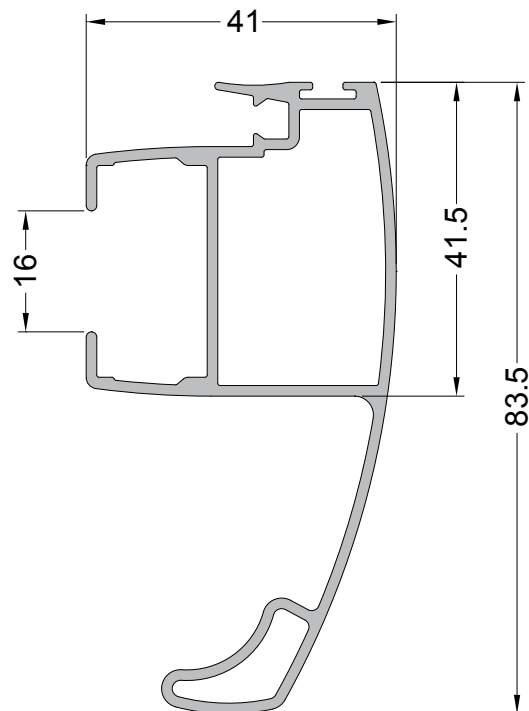

RE-40402  
0,944 kg/m  
Montante

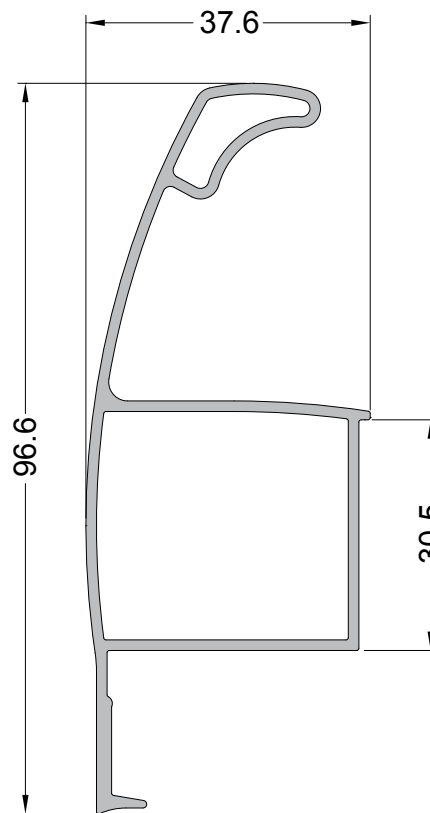

RE-40403  
0,973 kg/m  
Montante

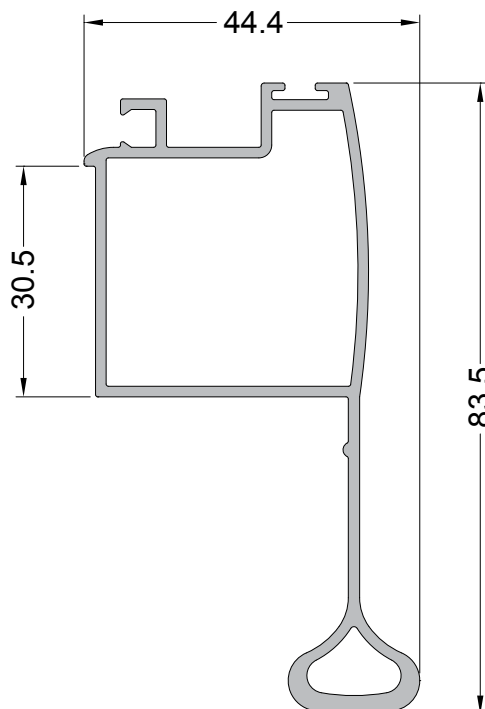

RE-40304  
1,151 kg/m  
Montante

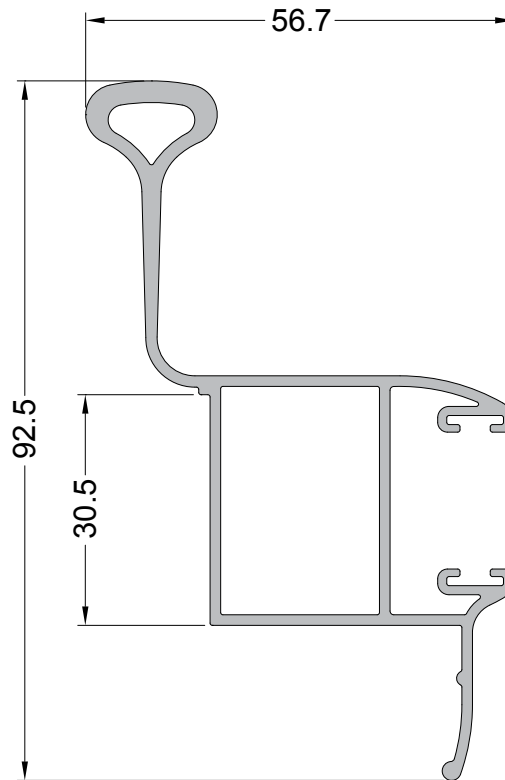

RE-40305  
0,726 kg/m  
Montante

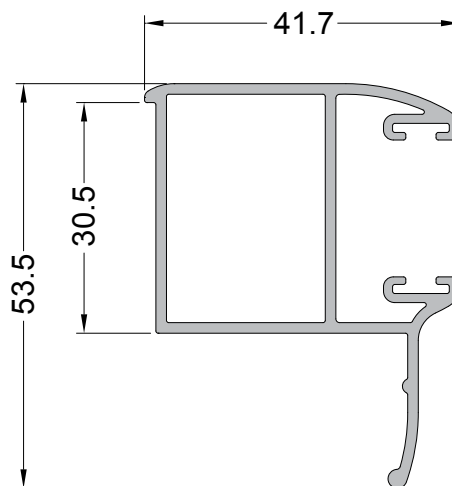



RE-40601

0,989 kg/m

Montante

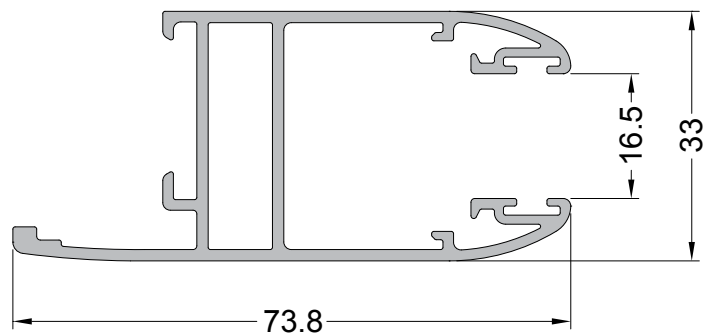

RE-78301

0,180 kg/m

Mata Junta

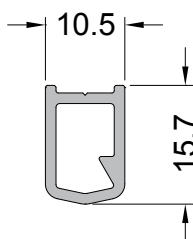

RE-78401

0,380 kg/m

Mata Junta

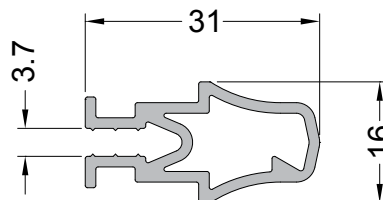

RE-78402

0,408 kg/m

Mata Junta

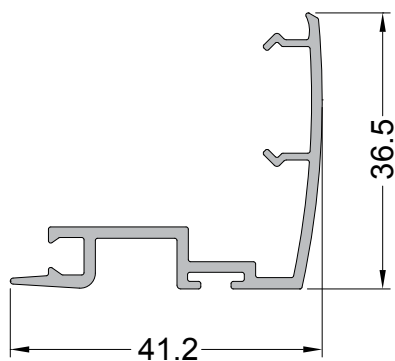

RE-78403

0,297 kg/m

Mata Junta

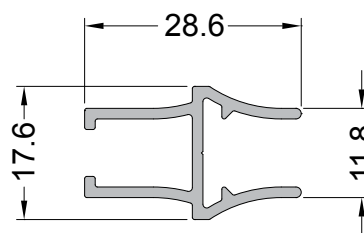

RE-72101  
0,216 kg/m  
Pingadeira

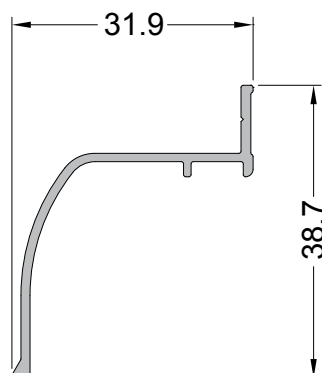

RE-72102  
0,289 kg/m  
Pingadeira

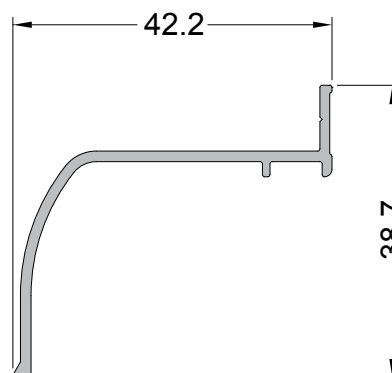

RE-70601  
0,147 kg/m  
Baguete

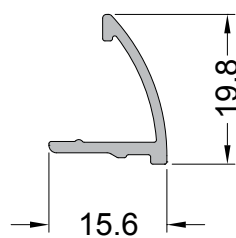

RE-82401  
0,190 kg/m  
Complemento

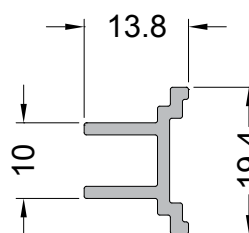

RE-79301  
0,138 kg/m  
Tampa

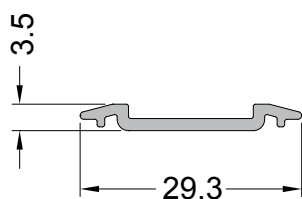

RE-99701  
0.447 Kg/m  
Complemento

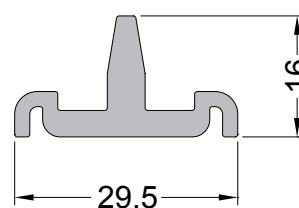

MA-0011  
1,033 Kg/m  
Marco

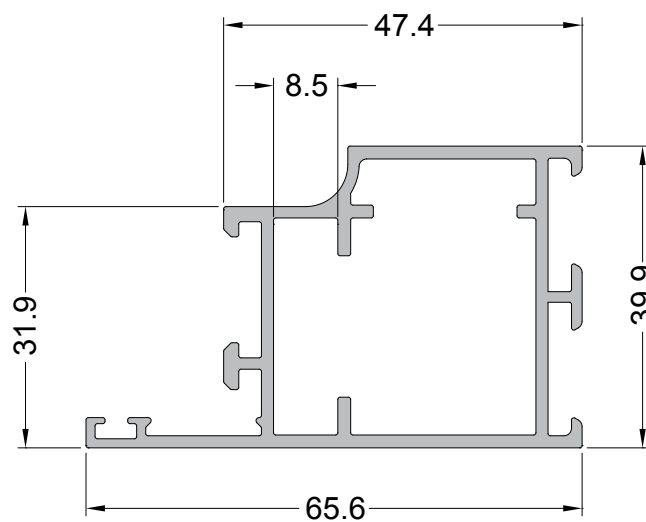

MA-03602  
1,204 Kg/m  
Marco

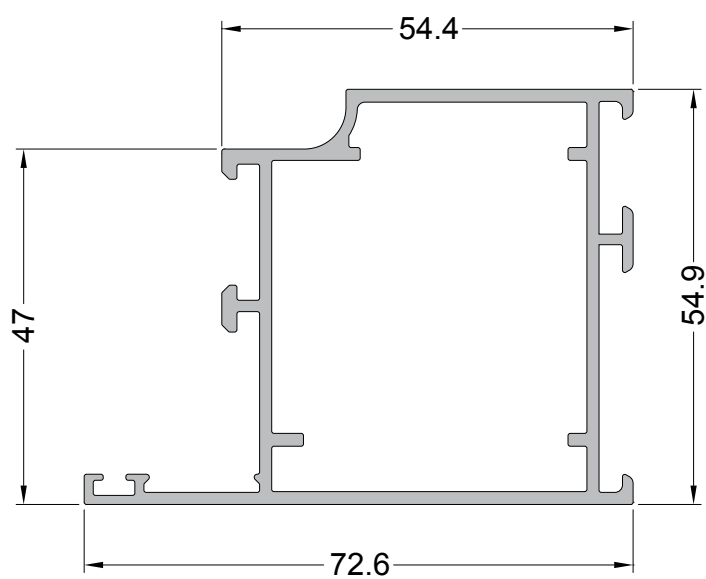

MA-04601

0,701 Kg/m

Marco

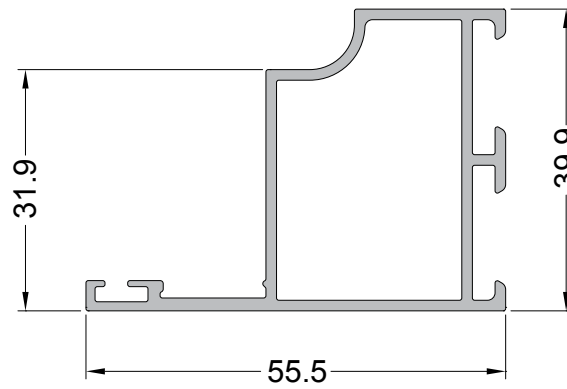

MA-09601

1,026 Kg/m

Marco

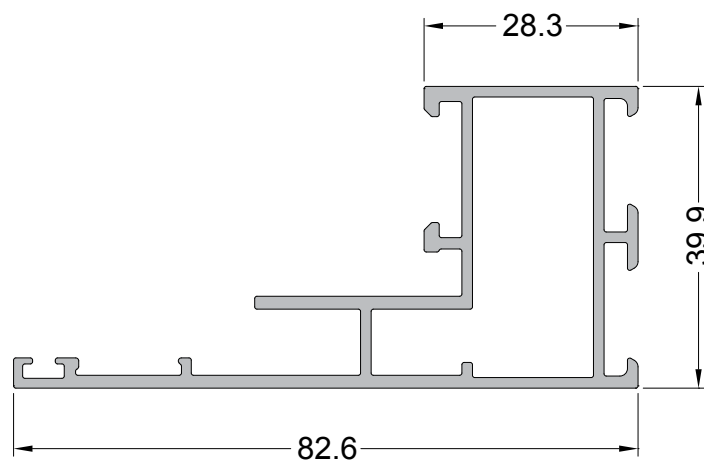

MA-09602

0,989 Kg/m

Marco

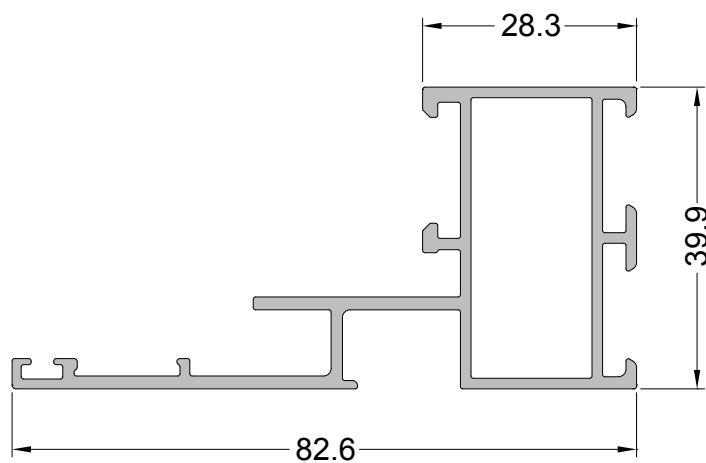

MA-42602

1,230 Kg/m

Folha

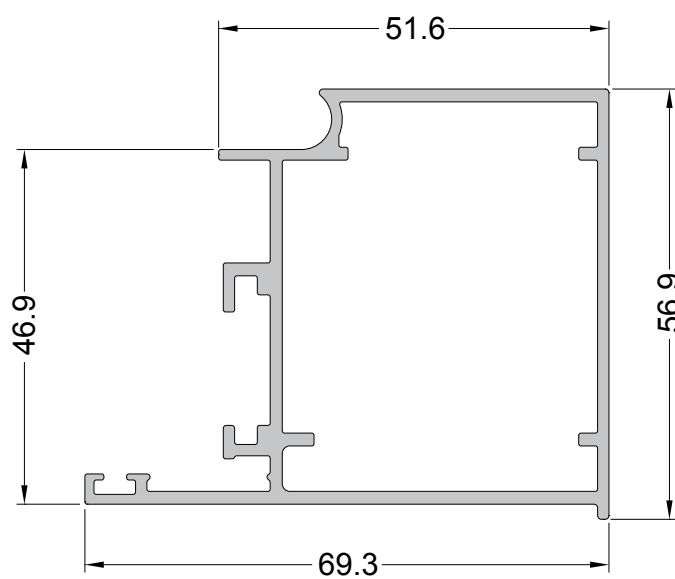

MA-42603

1,196 Kg/m

Folha

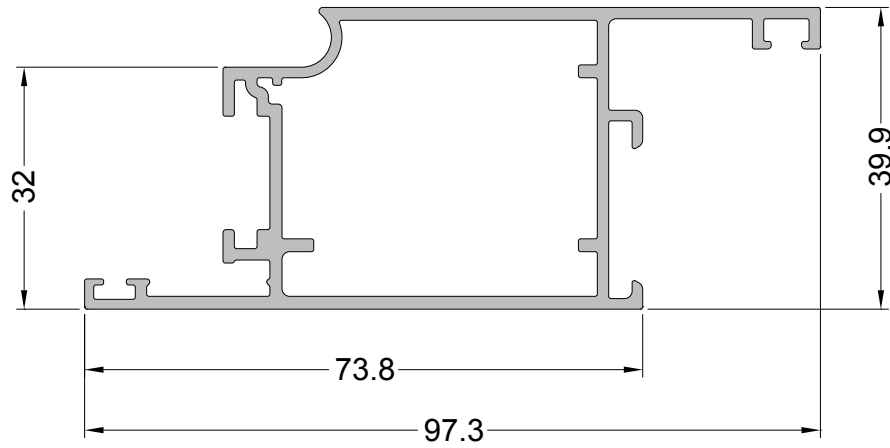

MA-44601

0,927 Kg/m

Folha

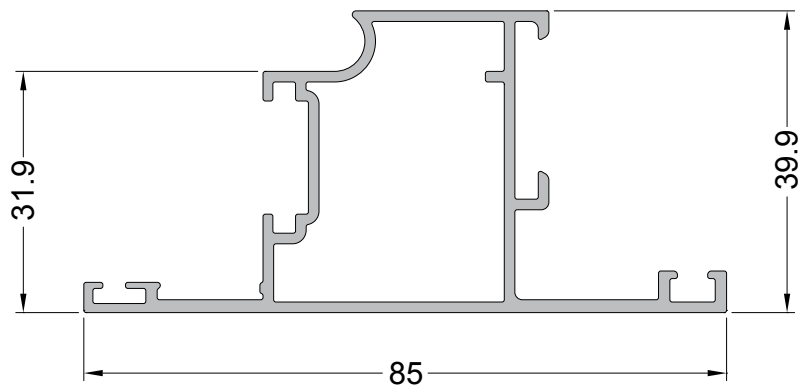

MA-1011  
1,230 Kg/m  
Folha

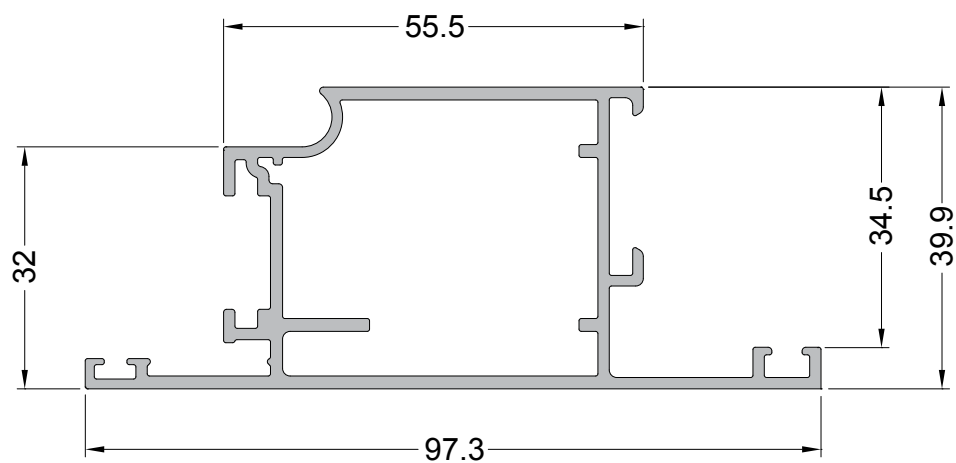

MA-49601  
0,813 Kg/m  
Folha

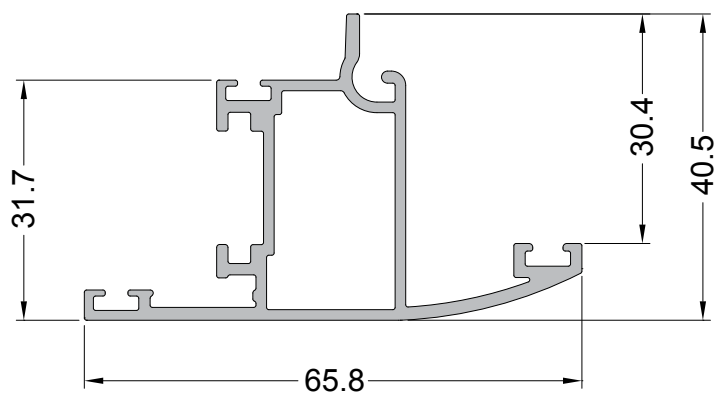

MA-22401

1,141 Kg/m

Travessa

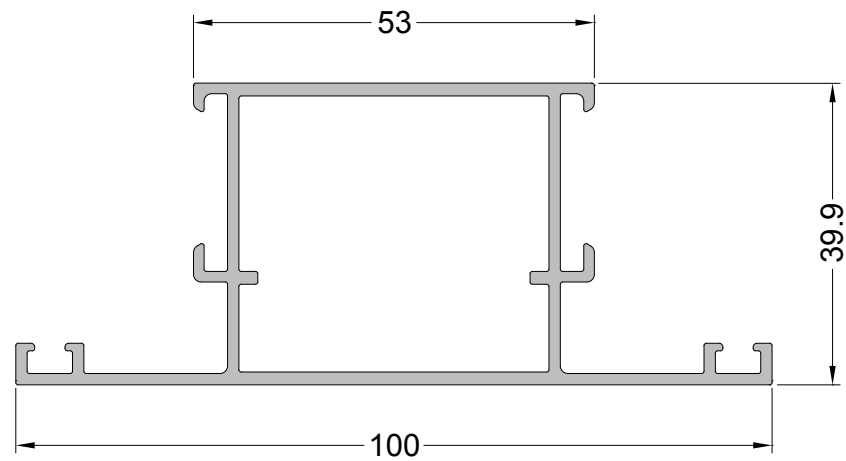

MA-82401

0,815 Kg/m

Complemento

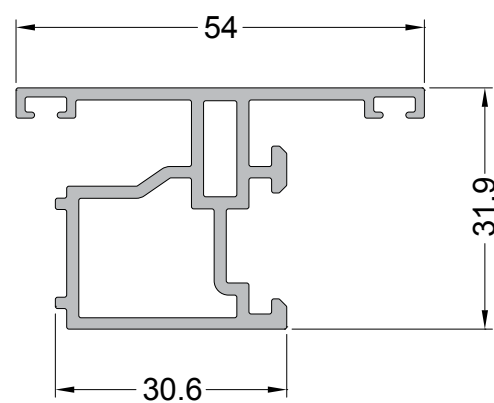



MA-3001  
0,187 Kg/m

Arremate

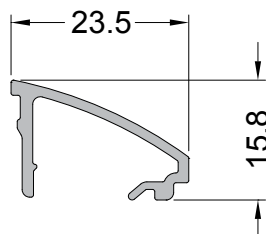

MA-70602  
0,133 Kg/m

Arremate

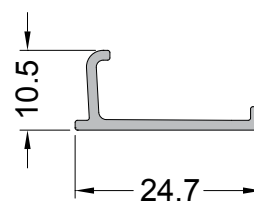

MA-79801  
0,374 Kg/m

Tampa

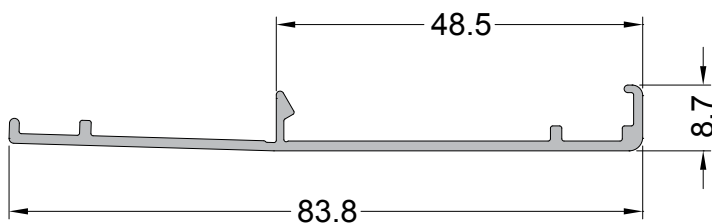

MA-73001  
0,447 Kg/m

Soleira

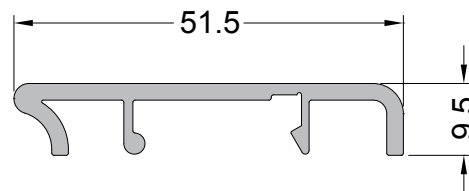

MA-82001  
0,236 Kg/m

Arremate inferior

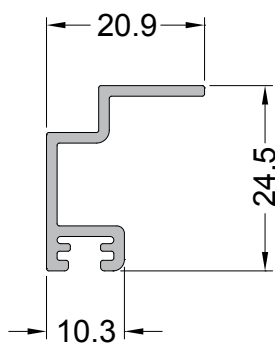

MA-6001  
0,231 Kg/m

Arremate Inferior

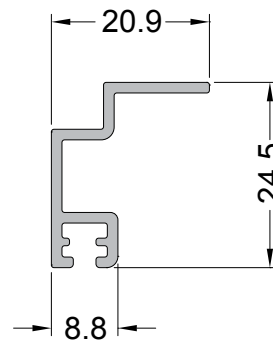

MD-01601

2.359 Kg/m

Marco

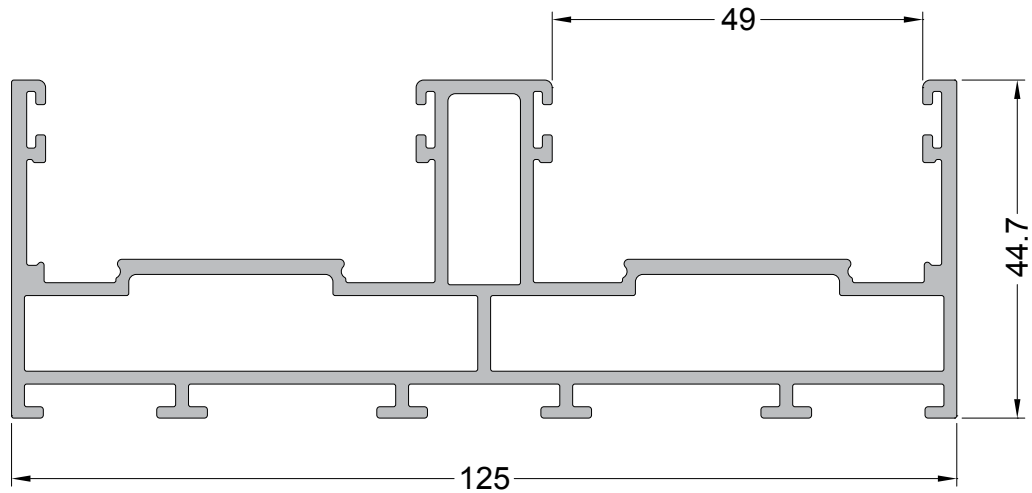

MD-40302

1.624 Kg/m

Marco de Giro

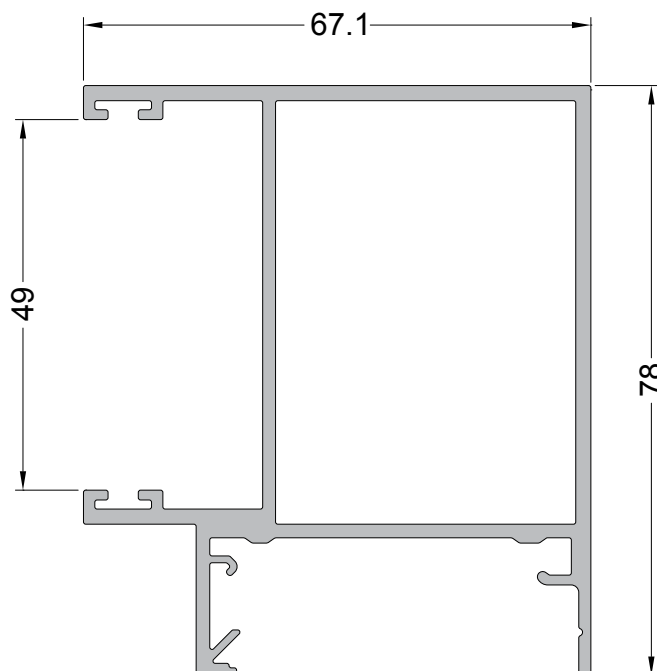

MD-40301

1.491 Kg/m

Folha Lateral

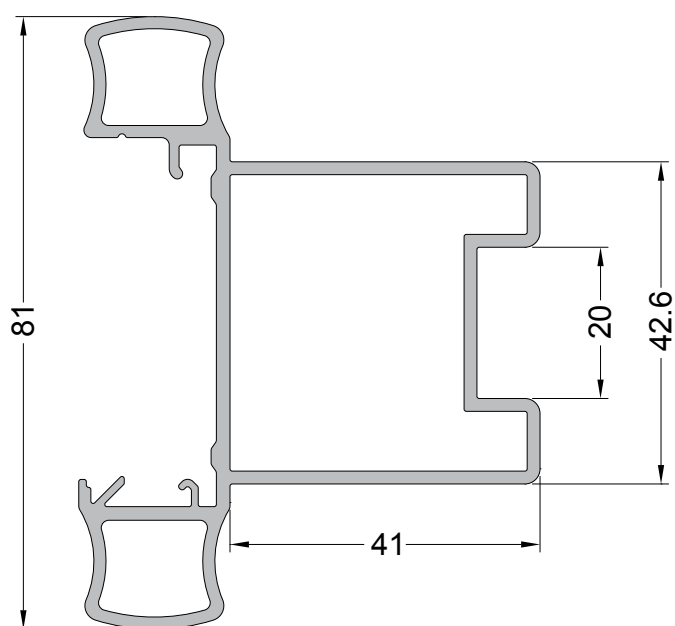

MD-20001

0.881 Kg/m

Travessa inferior

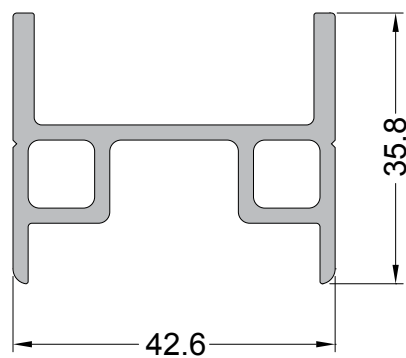

MD-40601

0.431 kg/m

Montante folha

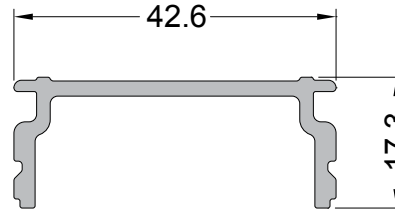

MD-78501

0.618 kg/m

Mata-Junta Lateral

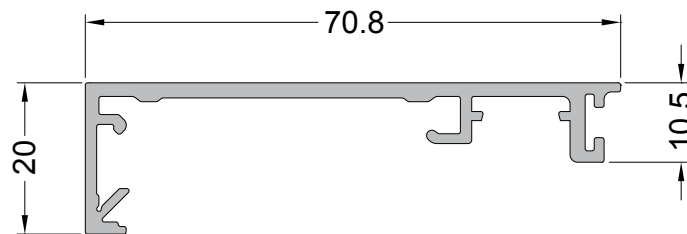

MD-79601

0.661 kg/m

Tampa Contorno

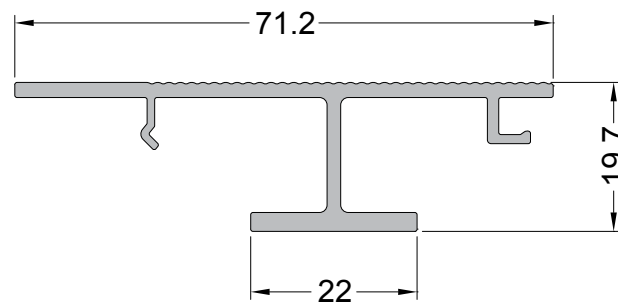

MD-81001

0.446 kg/m

Trilho

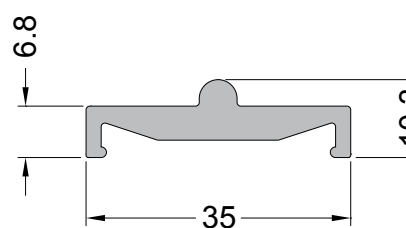

UP-021  
1.263 Kg/m  
Marco

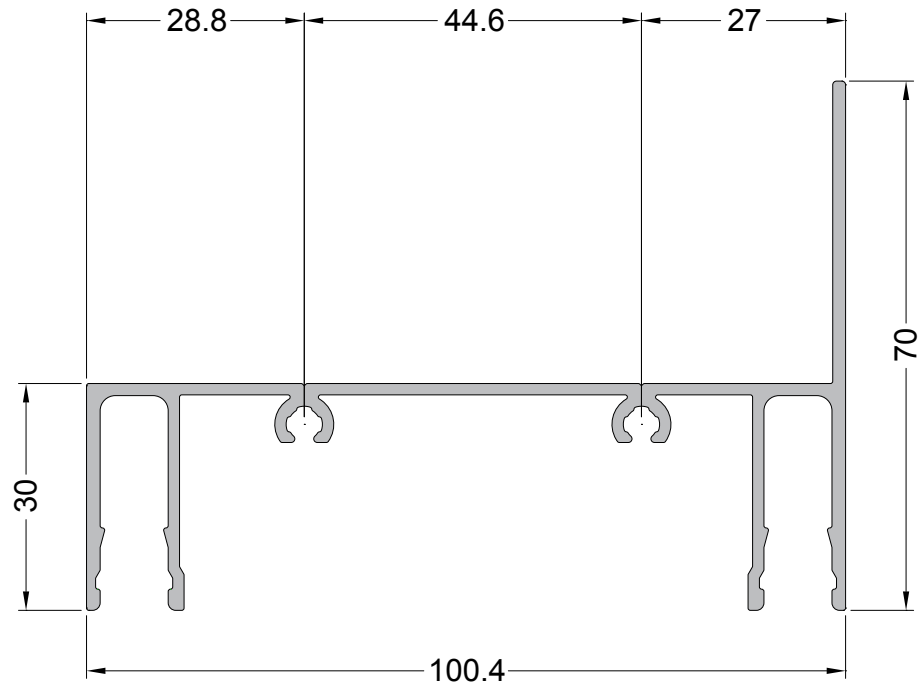

UP-020  
1.444 Kg/m  
Marco

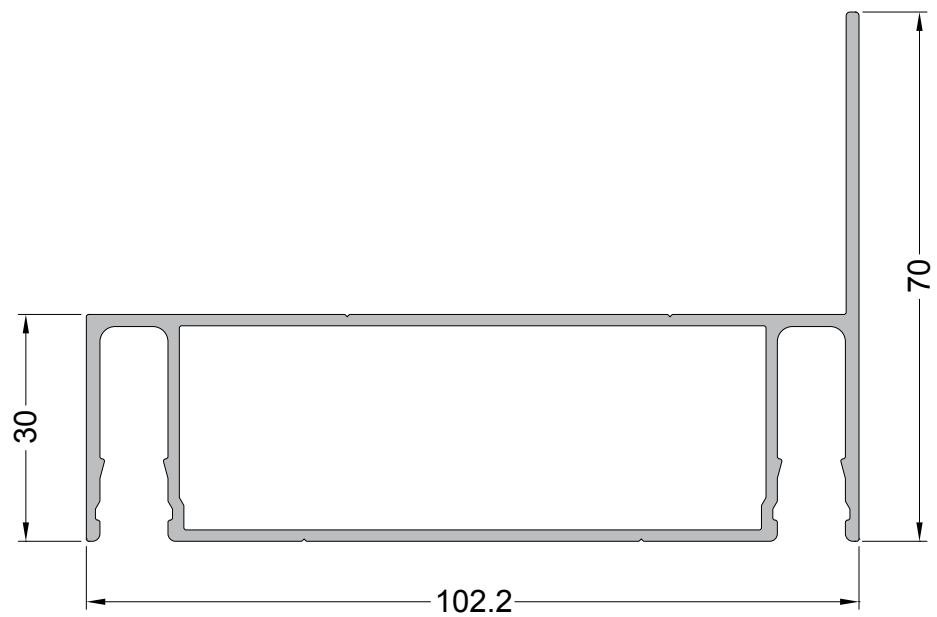

UP-010  
0.704 Kg/m  
Folha

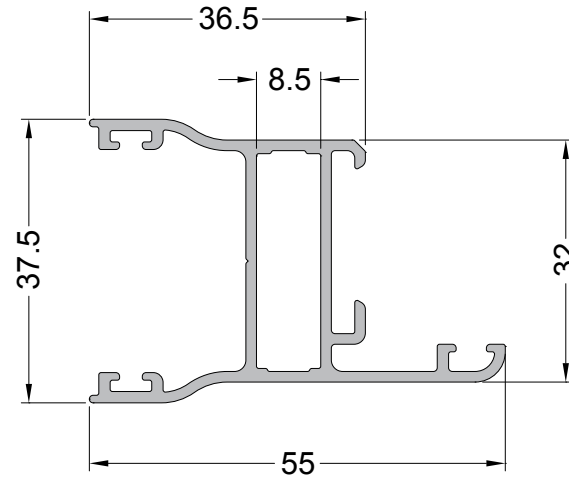

UP-011  
1.049 Kg/m  
Folha

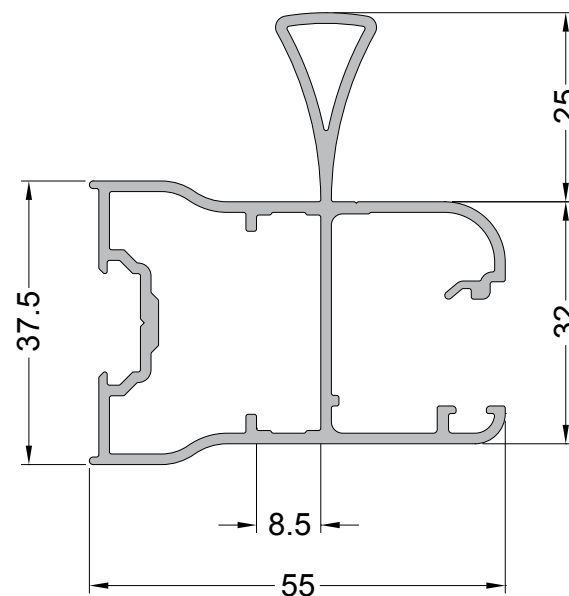

UP-050  
0.234 Kg/m  
Mata-Junta

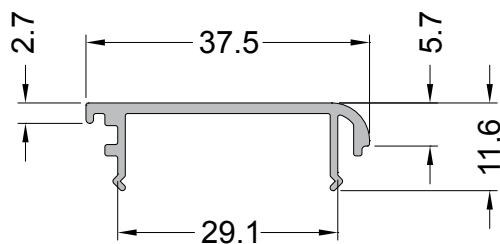

UP-060  
0.191 Kg/m  
Baguete

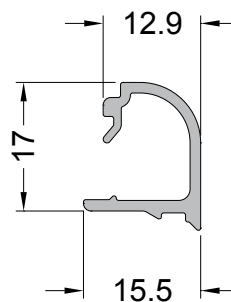

UP-051  
0.143 Kg/m  
Tampa Guia Lateral

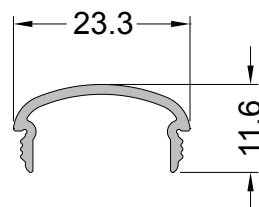

UP-052  
0.214 Kg/m  
Guia Lateral

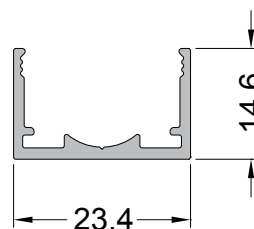

UP-200  
0.145 Kg/m  
Presilha

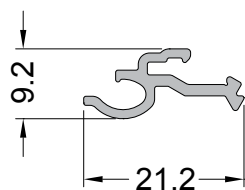

ALG-2100  
1,027 Kg/m  
Coluna

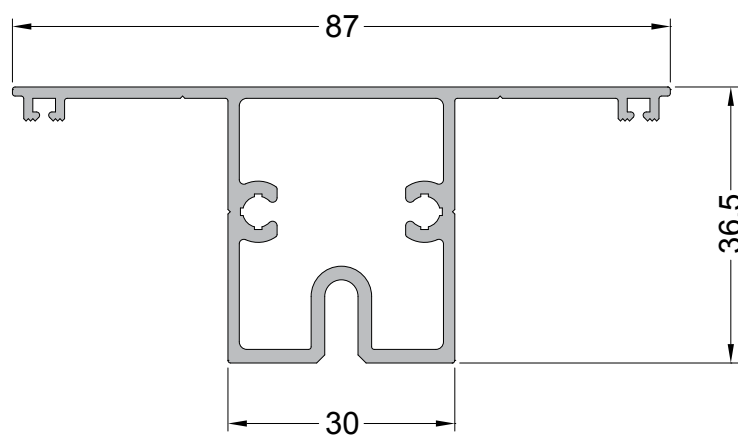

ALG-2004  
0,980 Kg/m  
Coluna

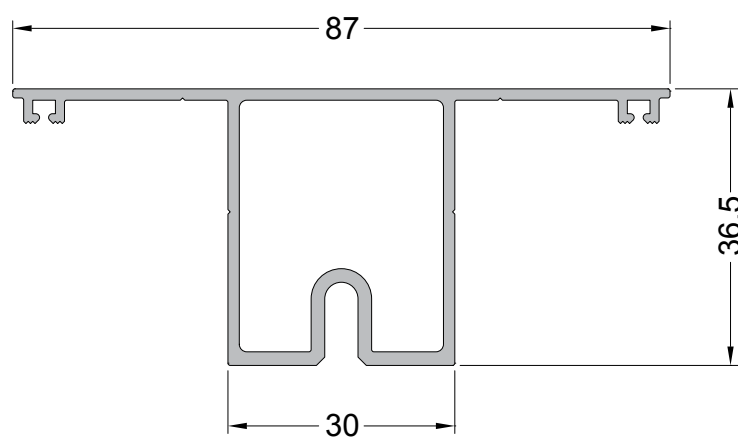



ALG-2024 (CX-369)

1,471 Kg/m

Coluna Central

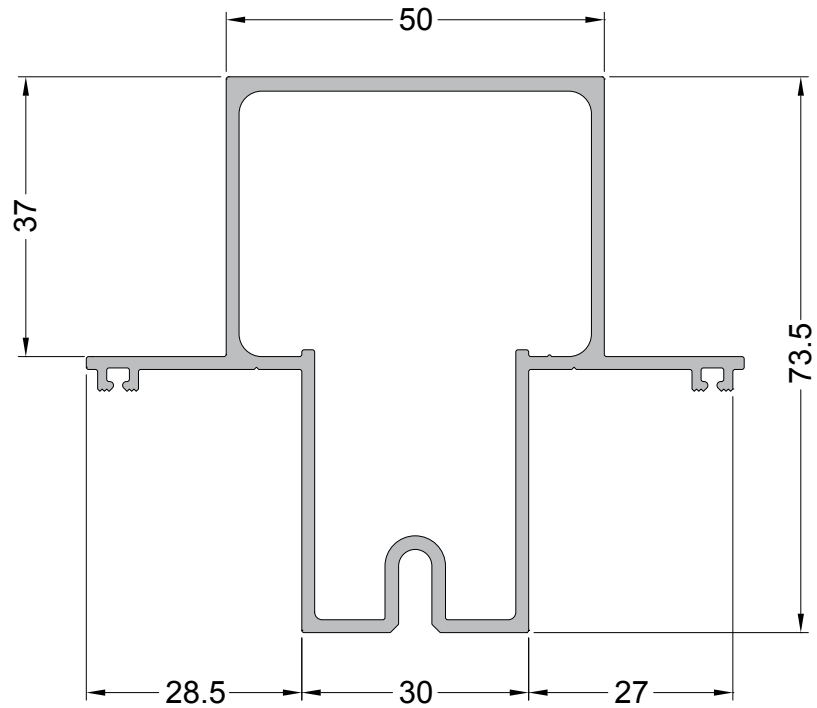

ALG-2045

1,688 Kg/m

Coluna Central

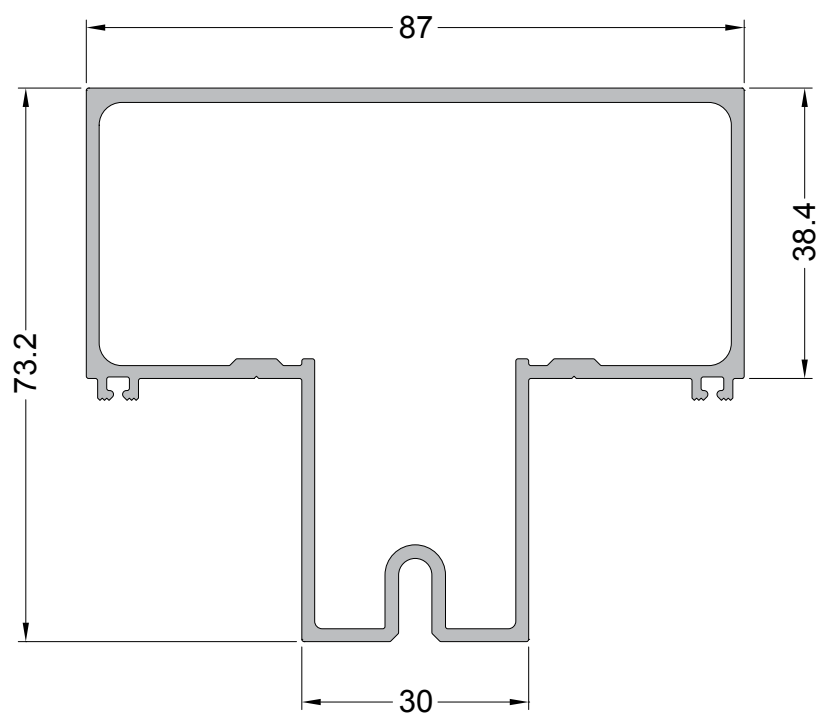

ALG-2048  
1,903 Kg/m  
Coluna Central

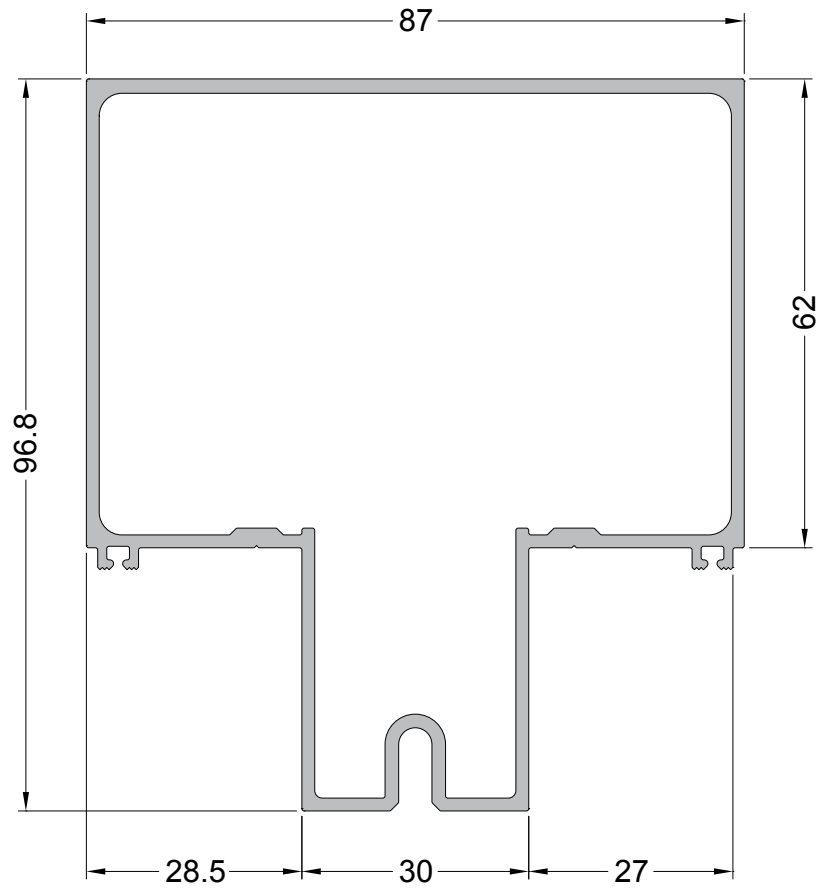

ALG-2000  
1,957 Kg/m  
Coluna Central

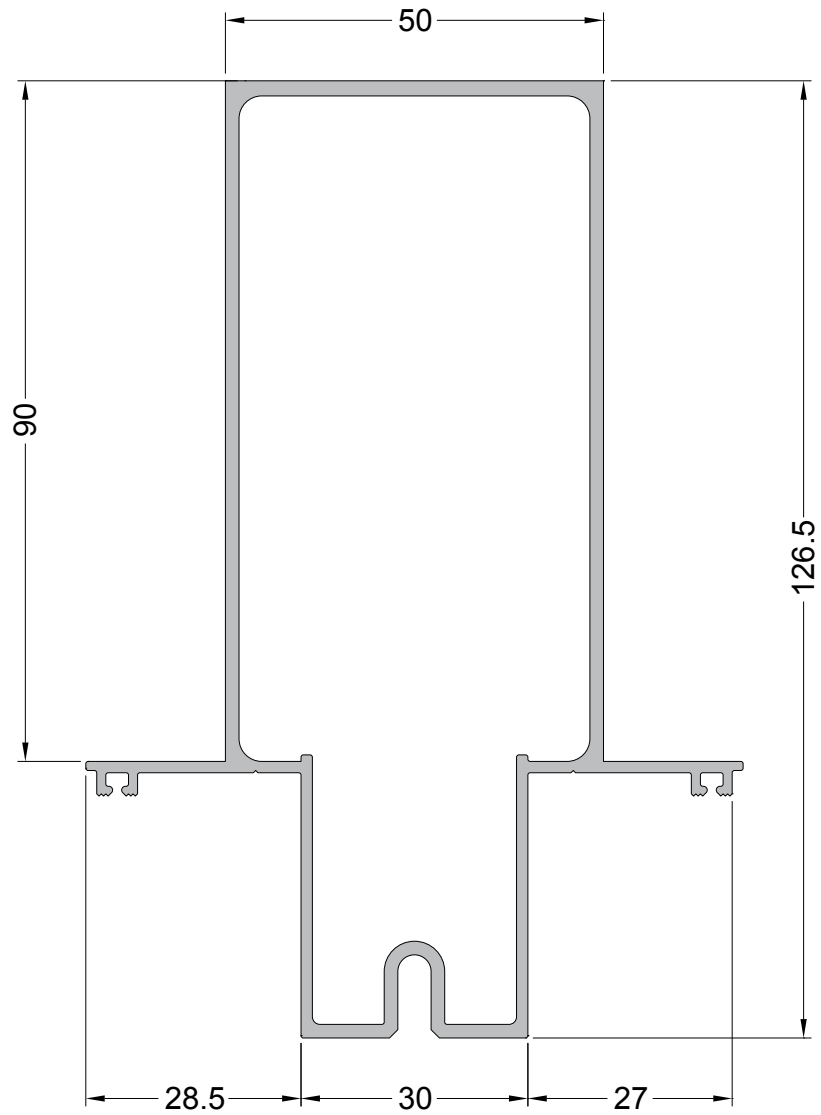

ALG-2040  
2,179 Kg/m  
Coluna Central

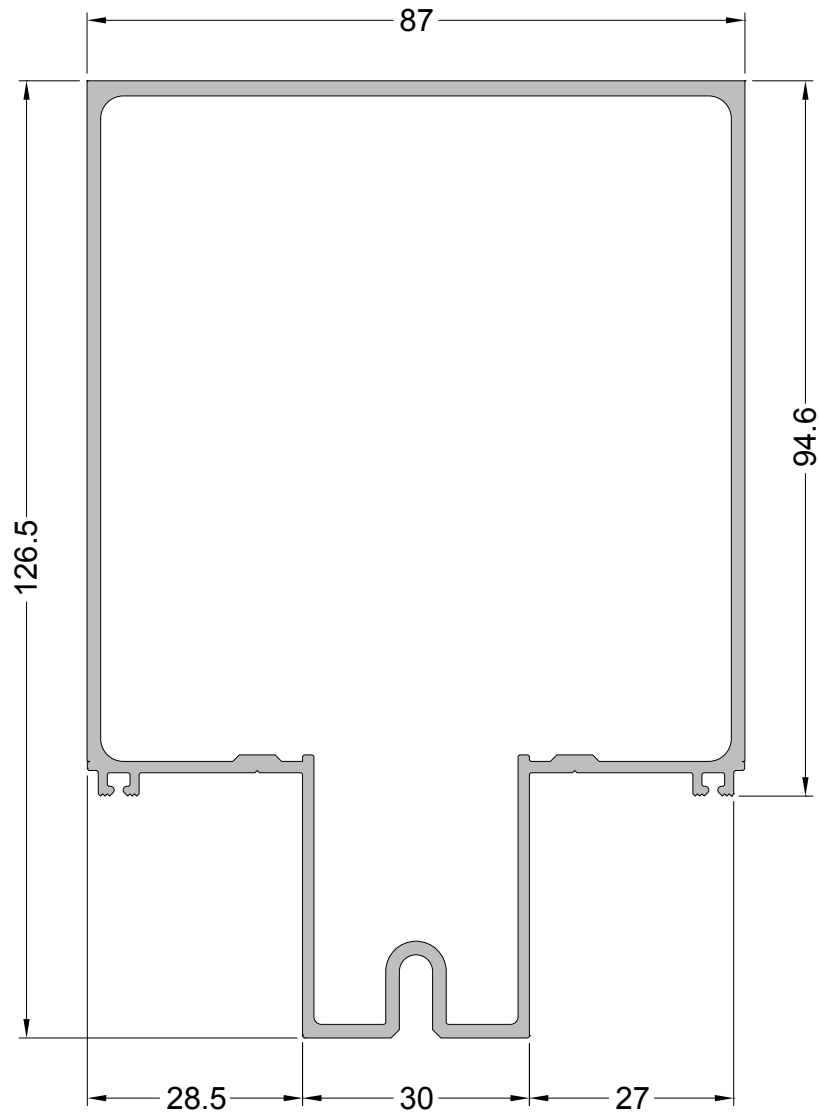

ALG-76401

3,571 Kg/m

Coluna Central

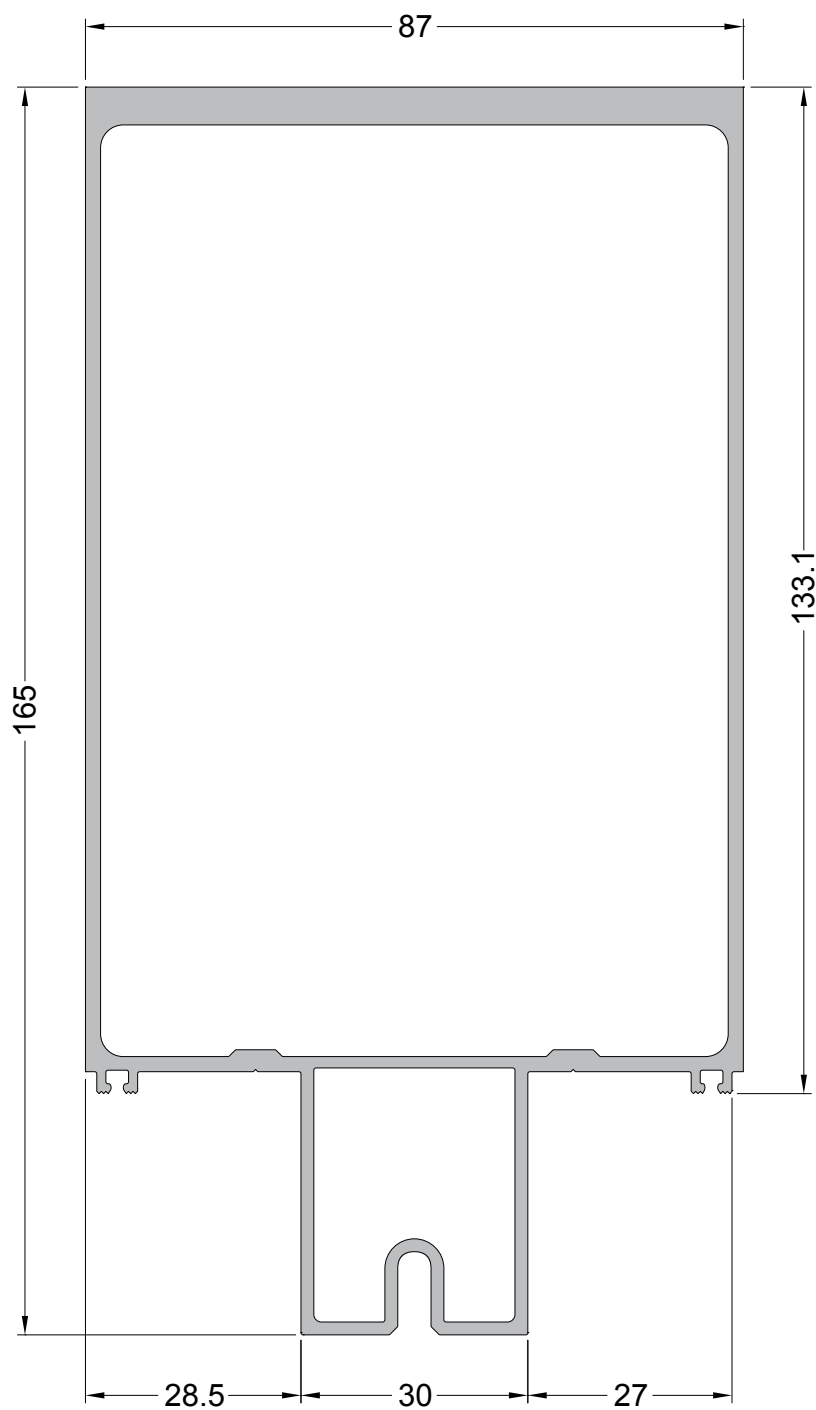

ALG-2070  
3,323 Kg/m  
Coluna Central

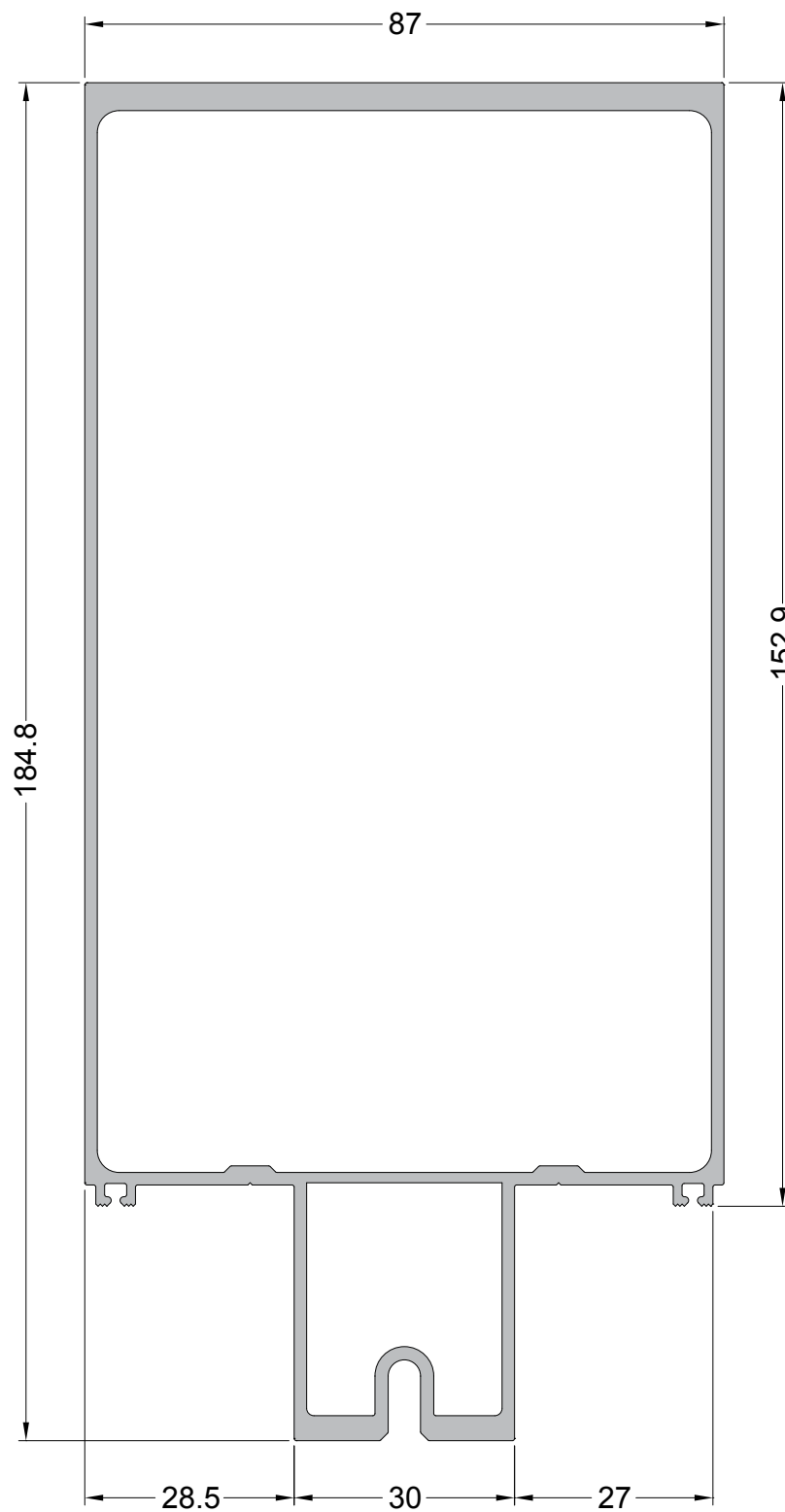

ALG-2006

1,397 Kg/m

Coluna de Canto

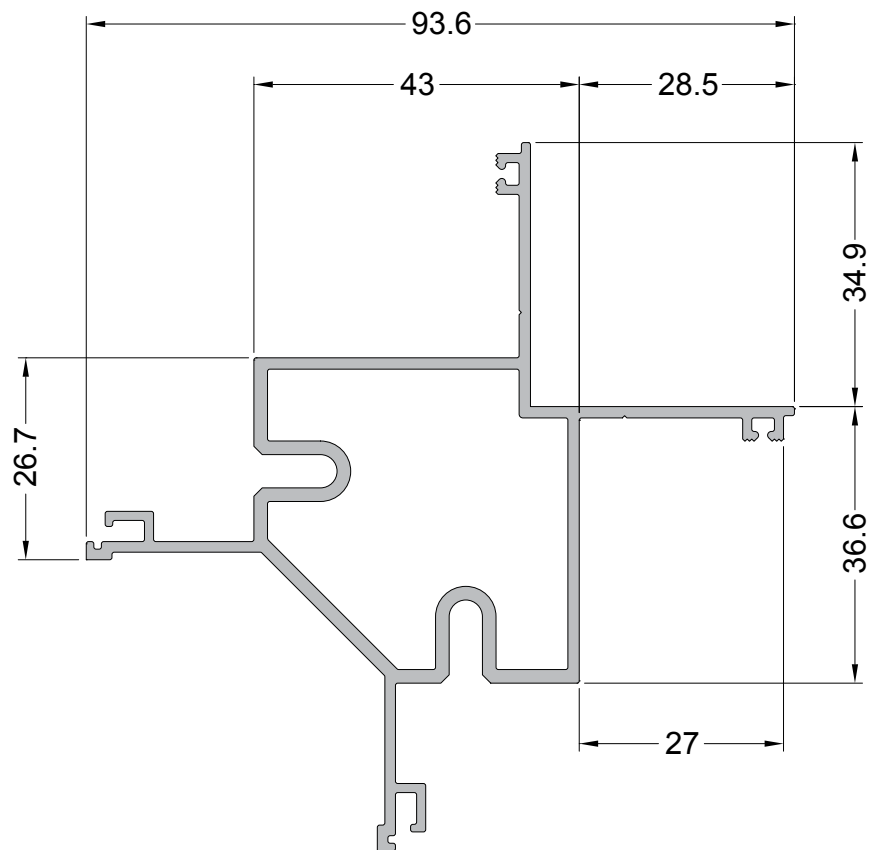

ALG-894  
2.227 Kg/m  
Coluna de Canto

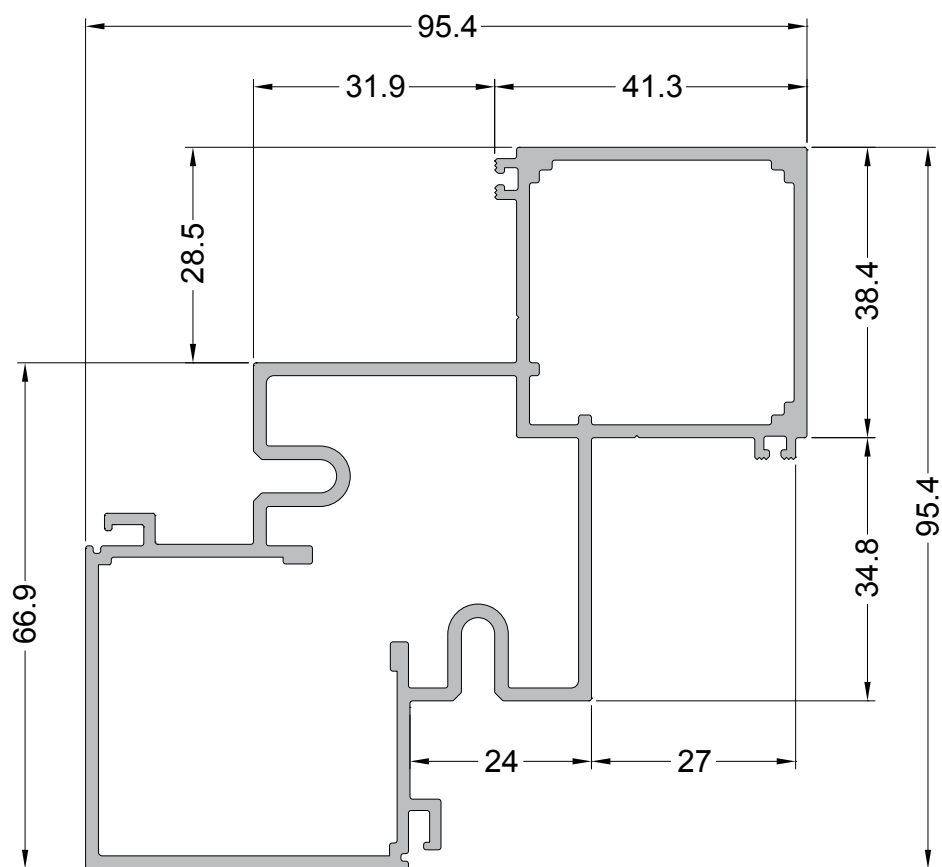



ALG-2052

2.828 Kg/m

Coluna de Canto

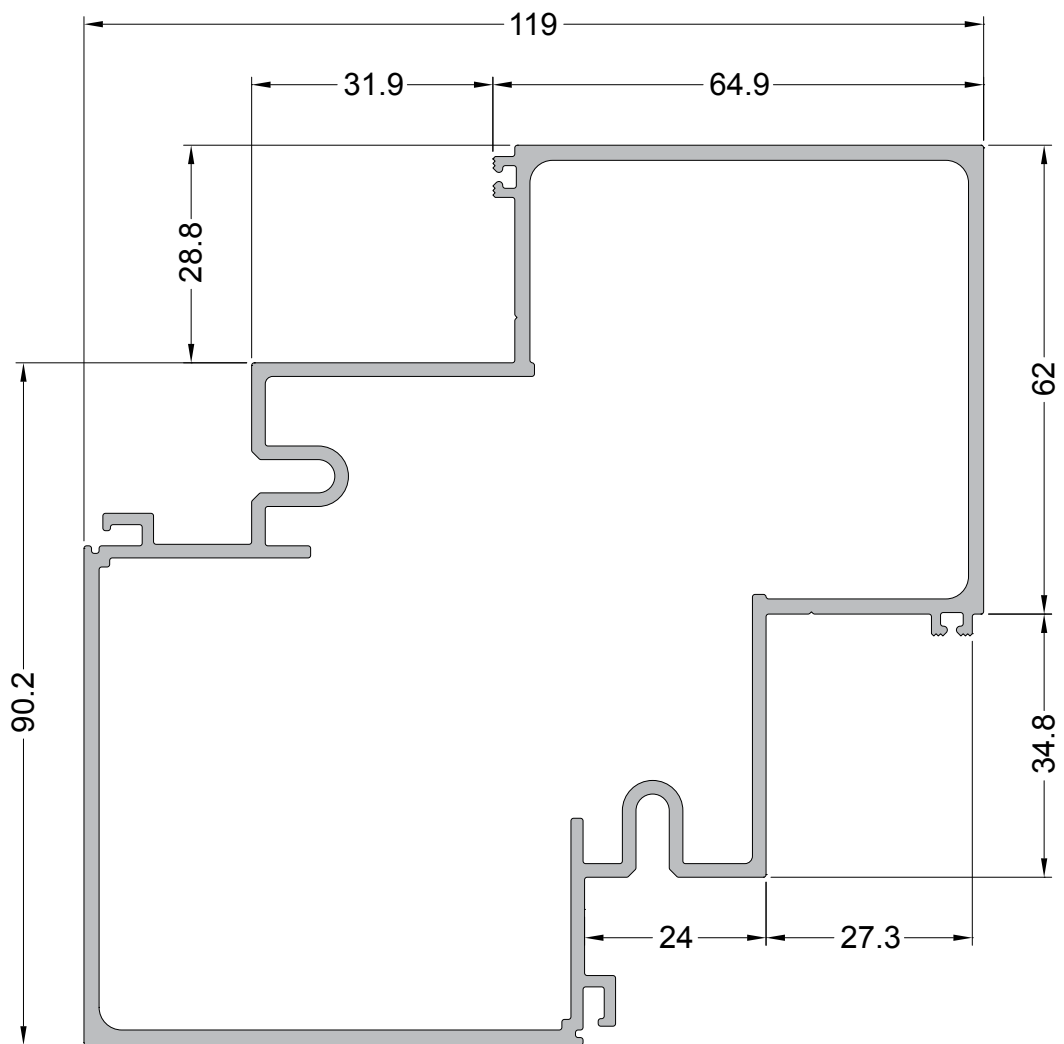

ALG-76305

2.361 Kg/m

Coluna de Canto

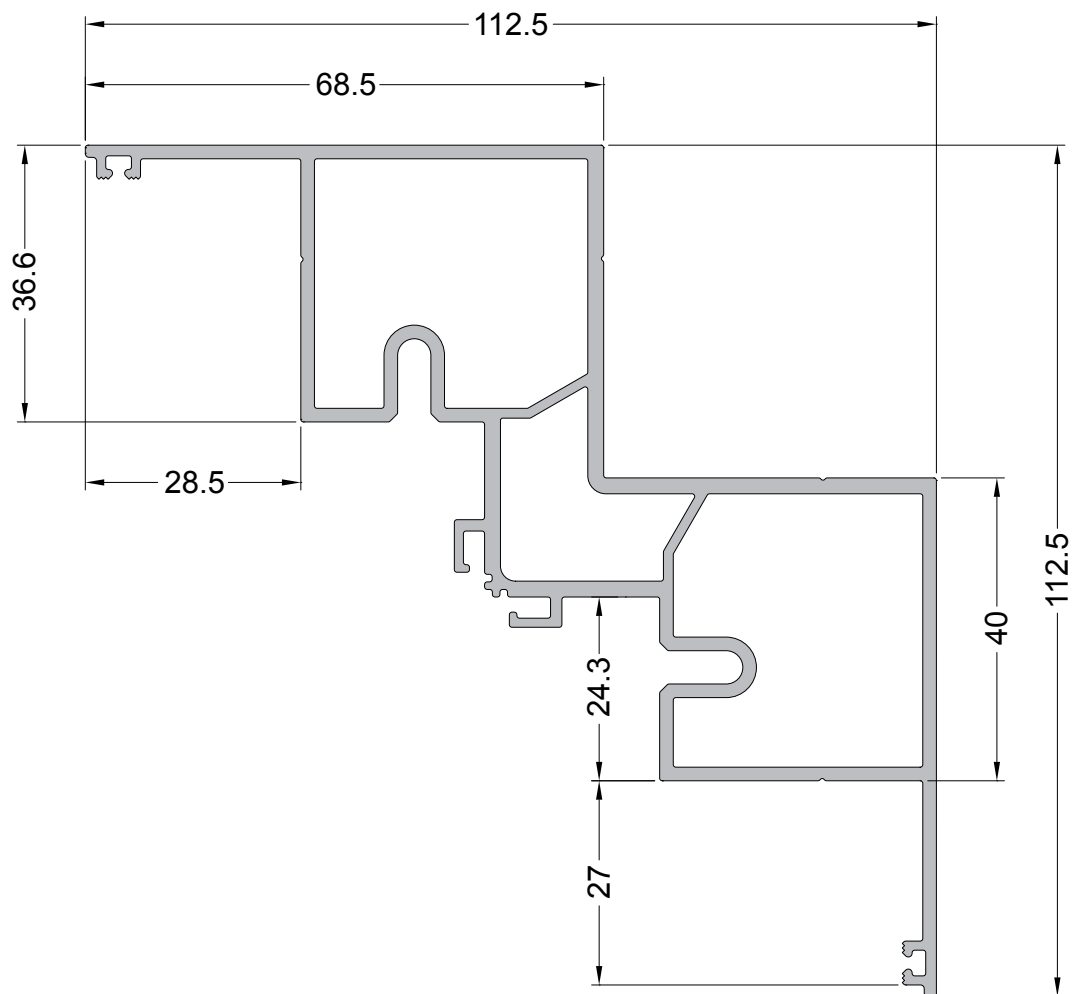

ALG-76307

3,241 kg/m

Coluna de Canto

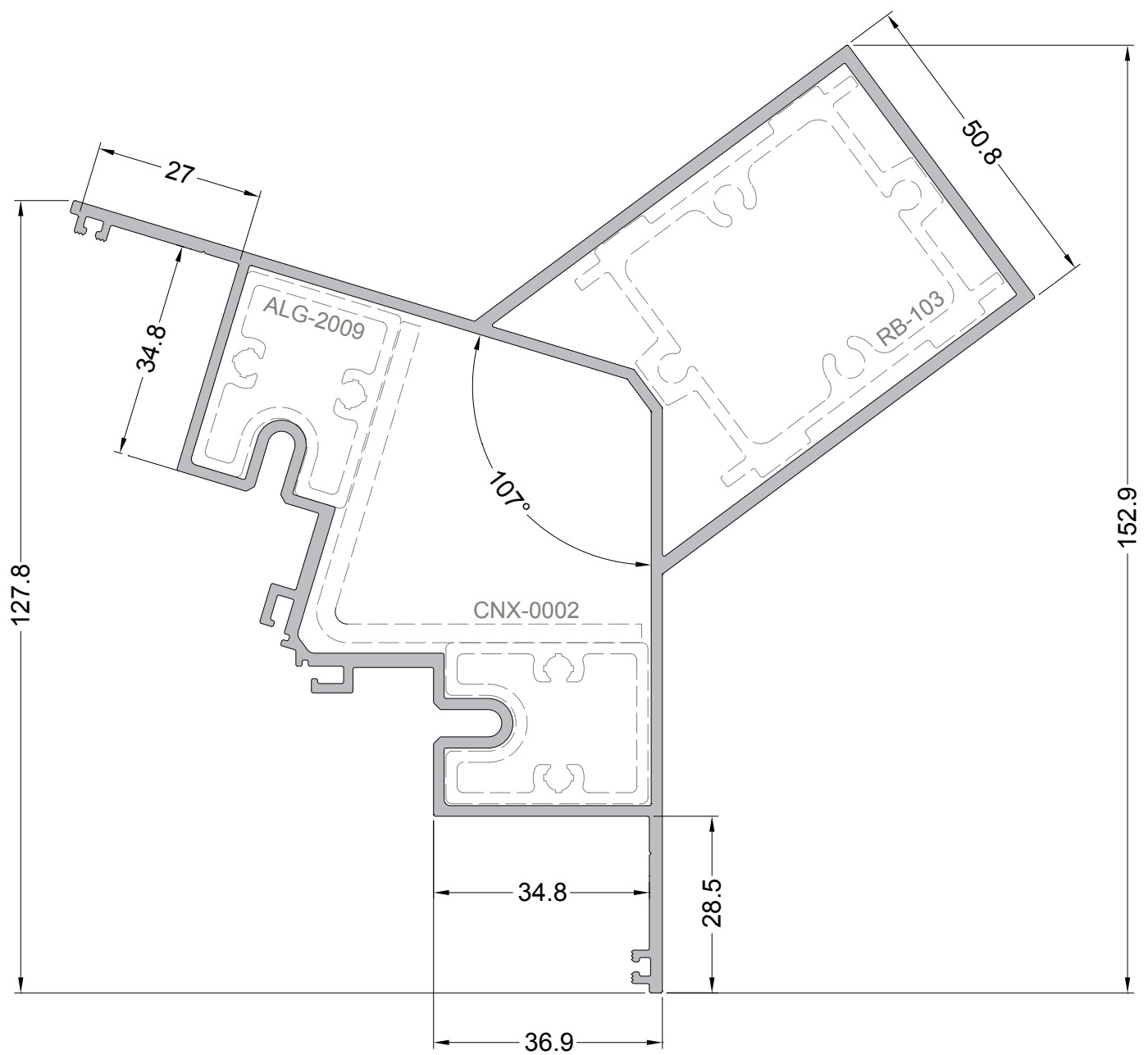

ALG-2005  
1,894 Kg/m  
Coluna Compl. Canto

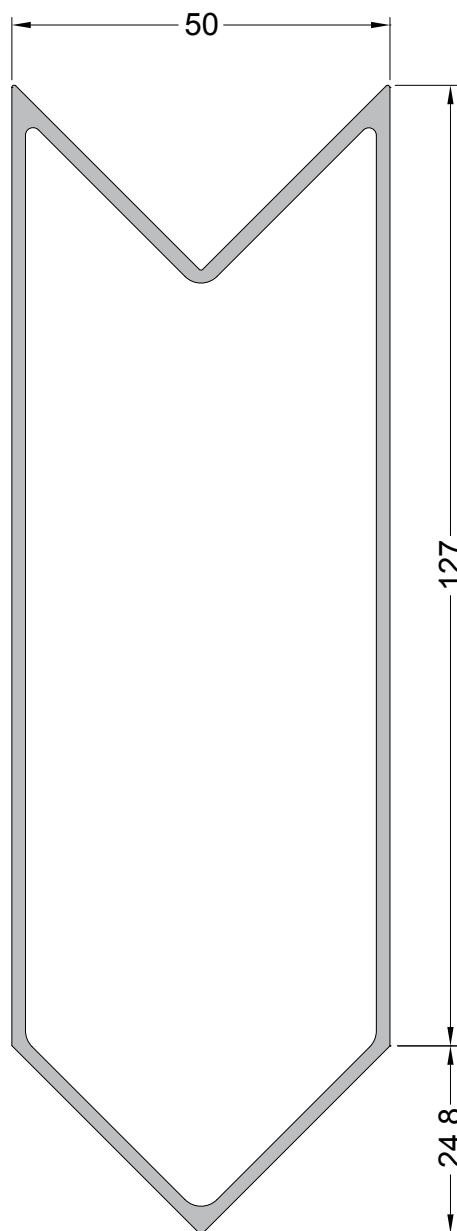

ALG-2032

1,982 Kg/m

Coluna em Ângulo

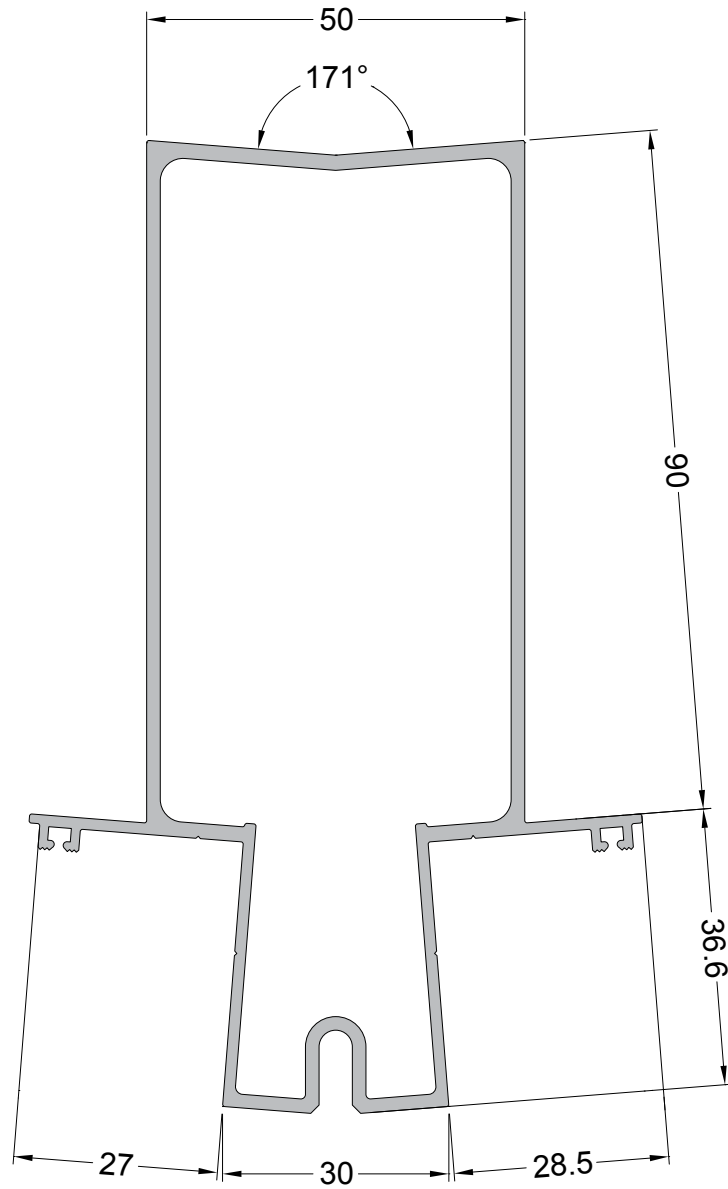

ALG-2008  
0,794 Kg/m  
Marco

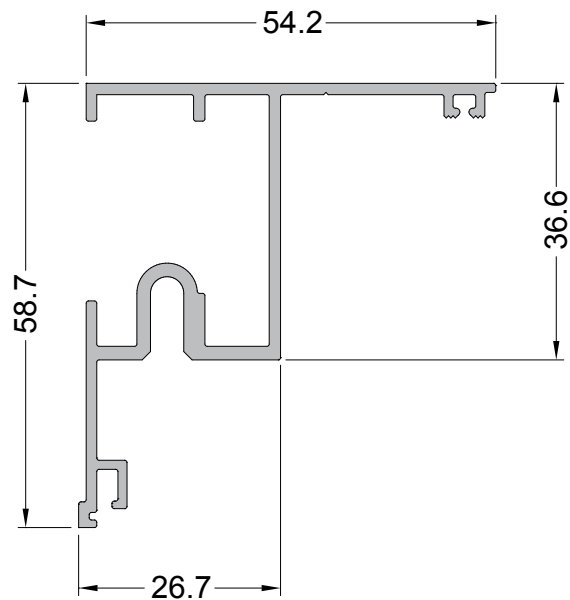

ALG-2022  
0.918 Kg/m  
Marco

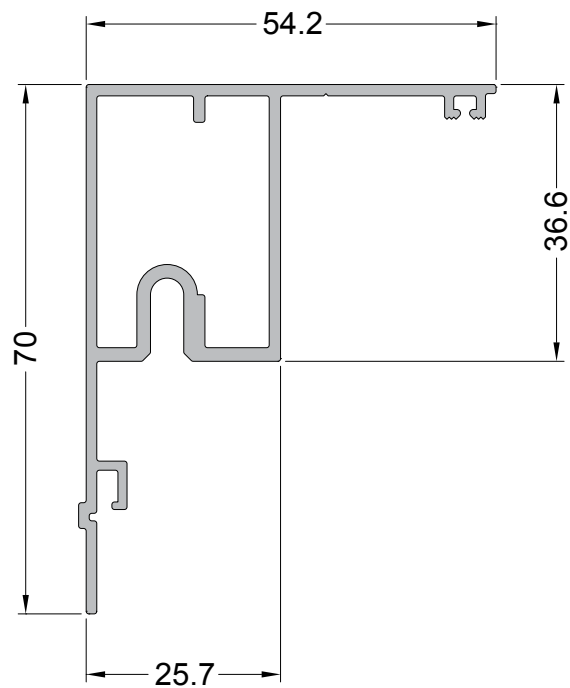

ALG-2025  
1,089 Kg/m  
Coluna Lateral

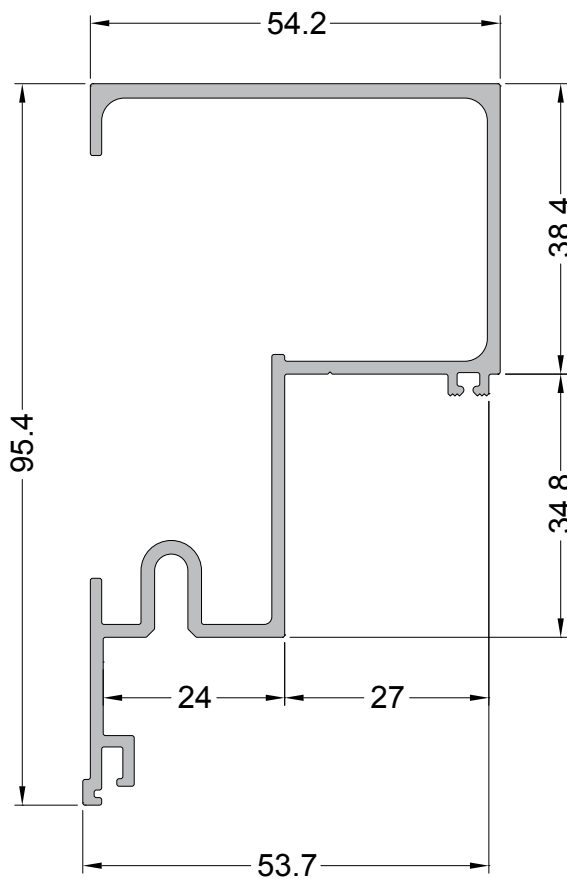
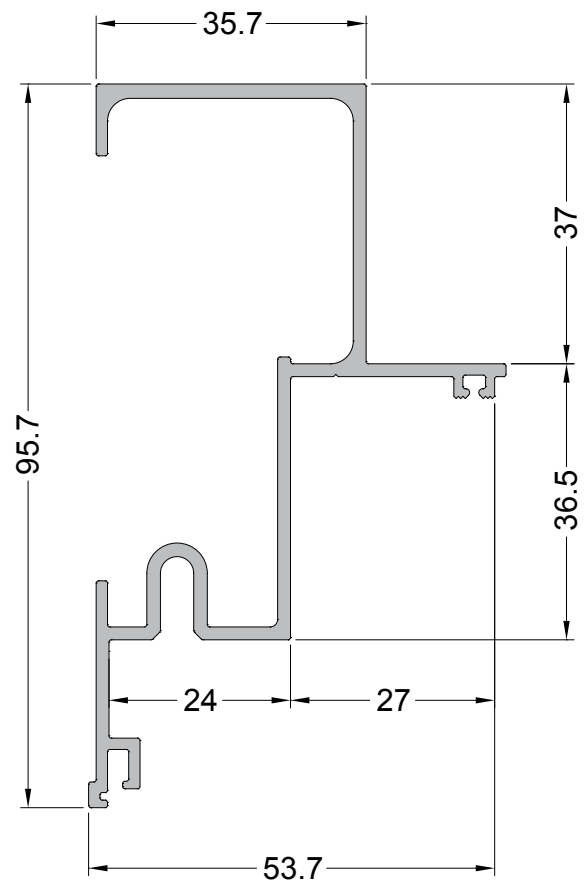

ALG-2047  
1,186 Kg/m  
Coluna Lateral

ALG-76306

1.566 Kg/m

Coluna Lateral

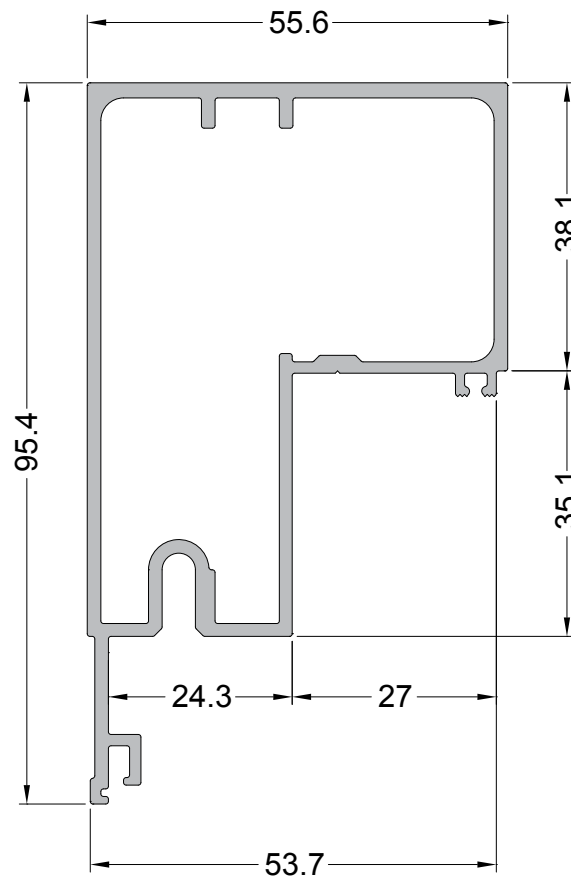



ALG-76302

1.892 Kg/m

Meia Coluna

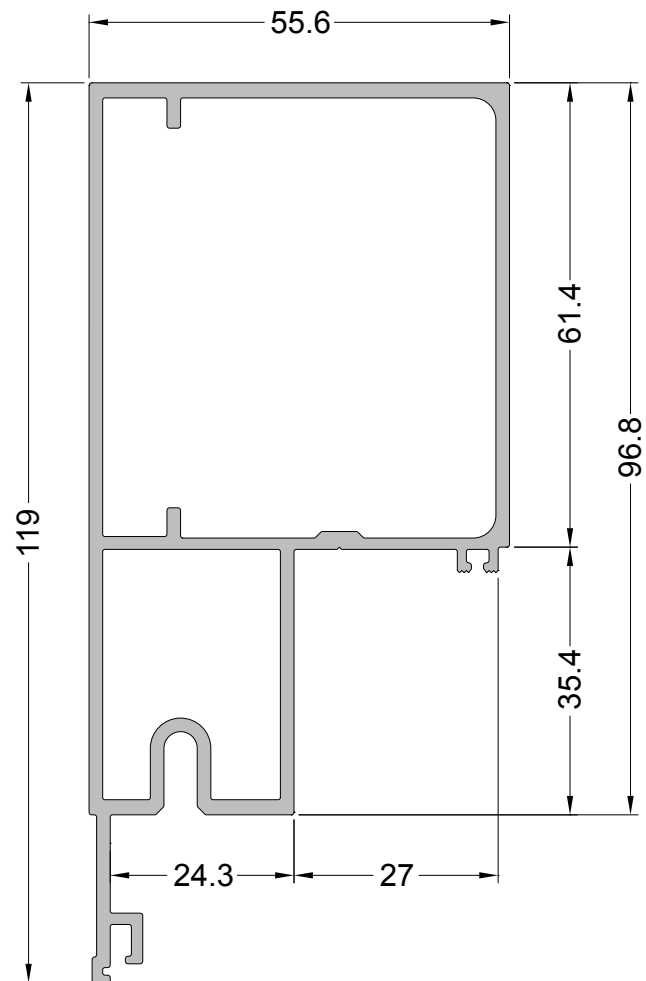

ALG-2050  
1,294 Kg/m  
Coluna Lateral

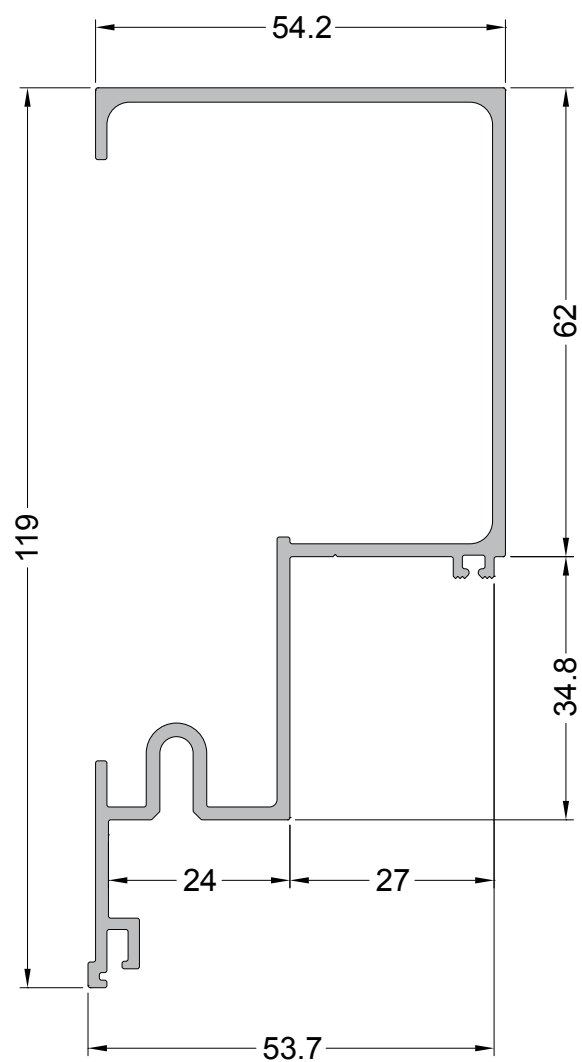

ALG-2002  
1,334 Kg/m  
Coluna Lateral

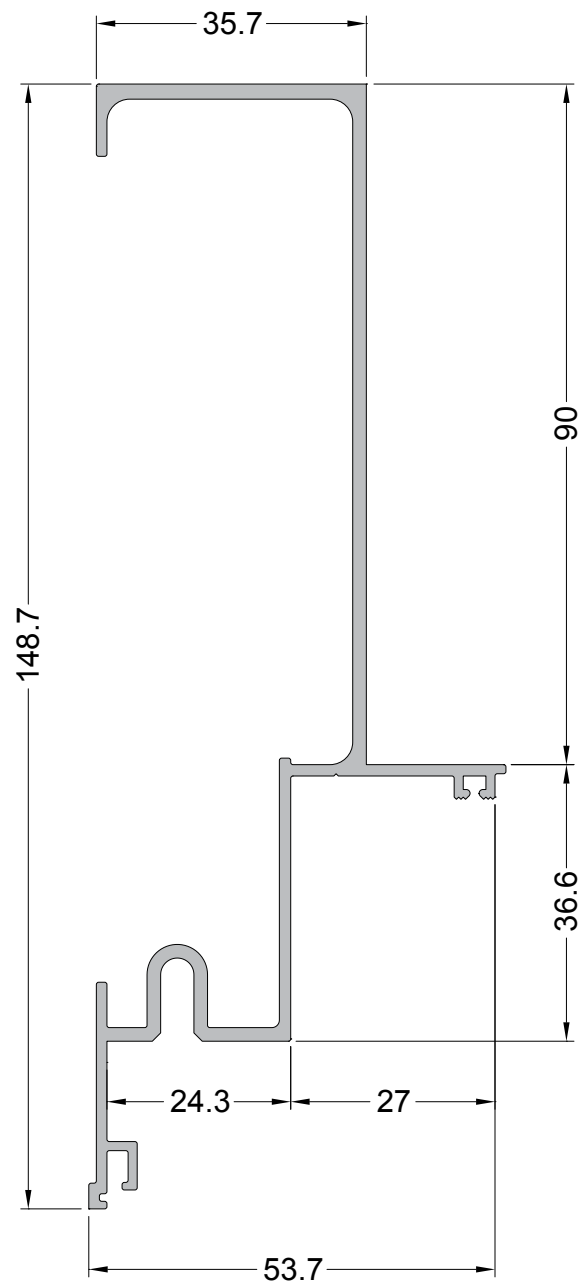

ALG-2041  
1,446 Kg/m  
Coluna Lateral

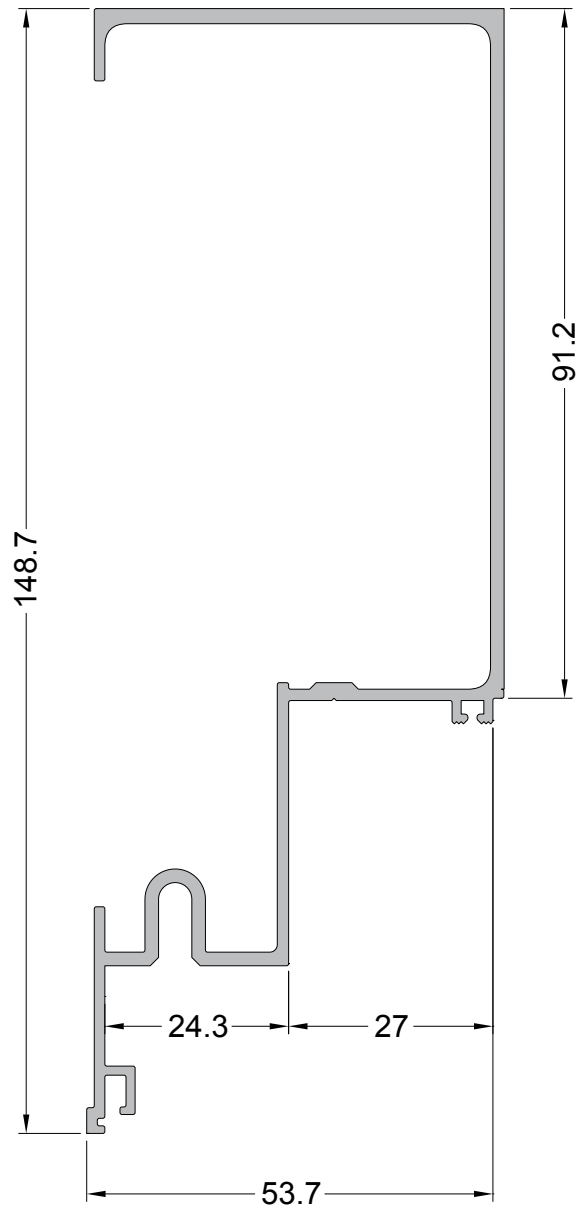

ALG-2011  
0,958 Kg/m  
Travessa

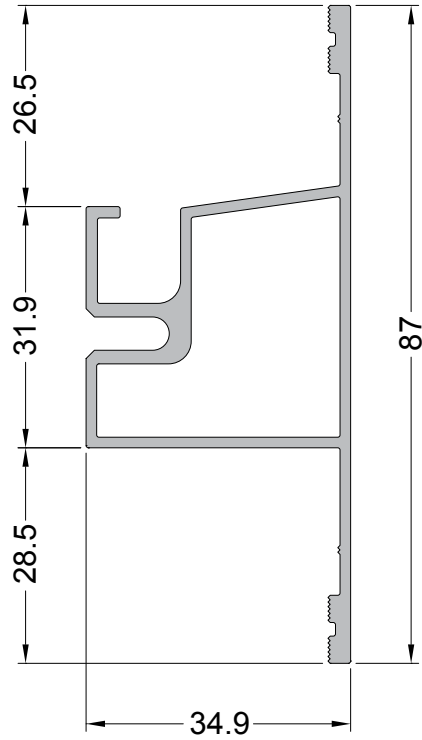

ALG-2034  
0,892 Kg/m  
Travessa em ângulo

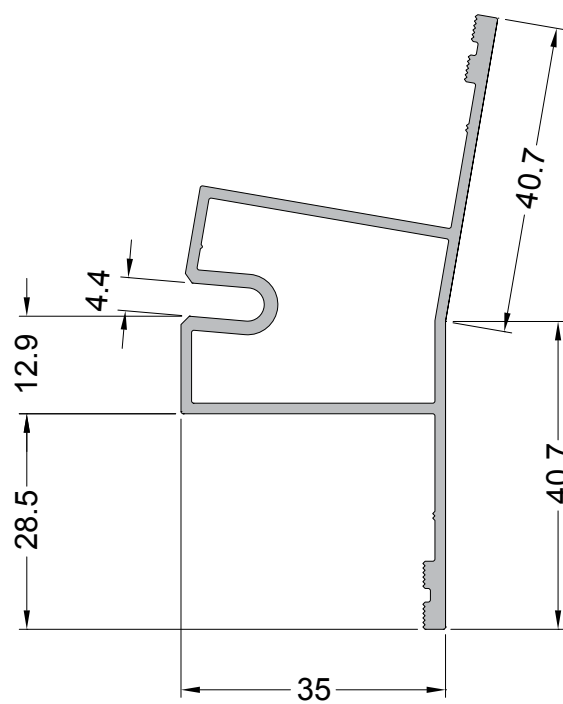

ALG-2029

1,658 Kg/m

Travessa para Brise  
Decorativo

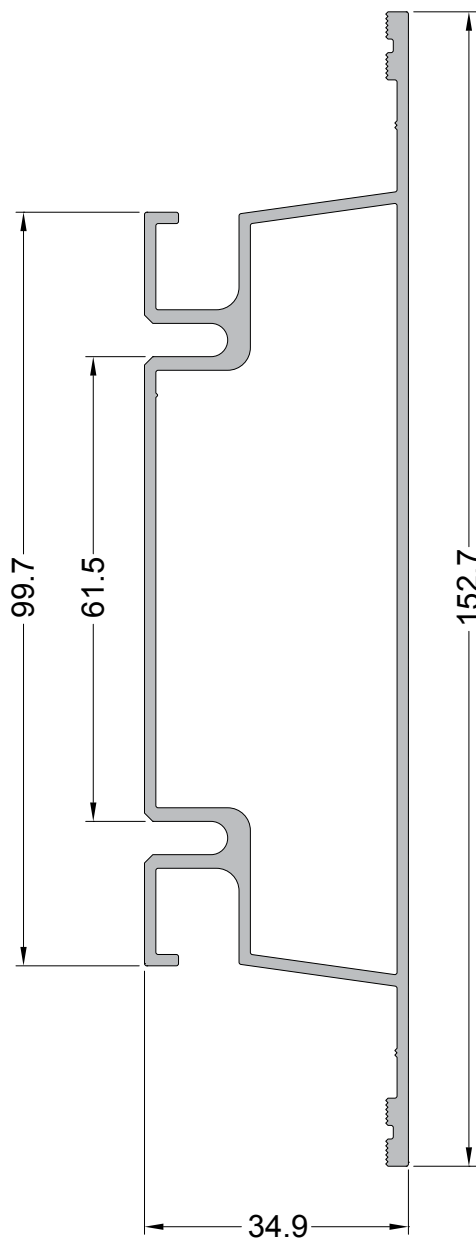

CX-3248

2.191 Kg/m

Travessa para Brise  
Decorativo

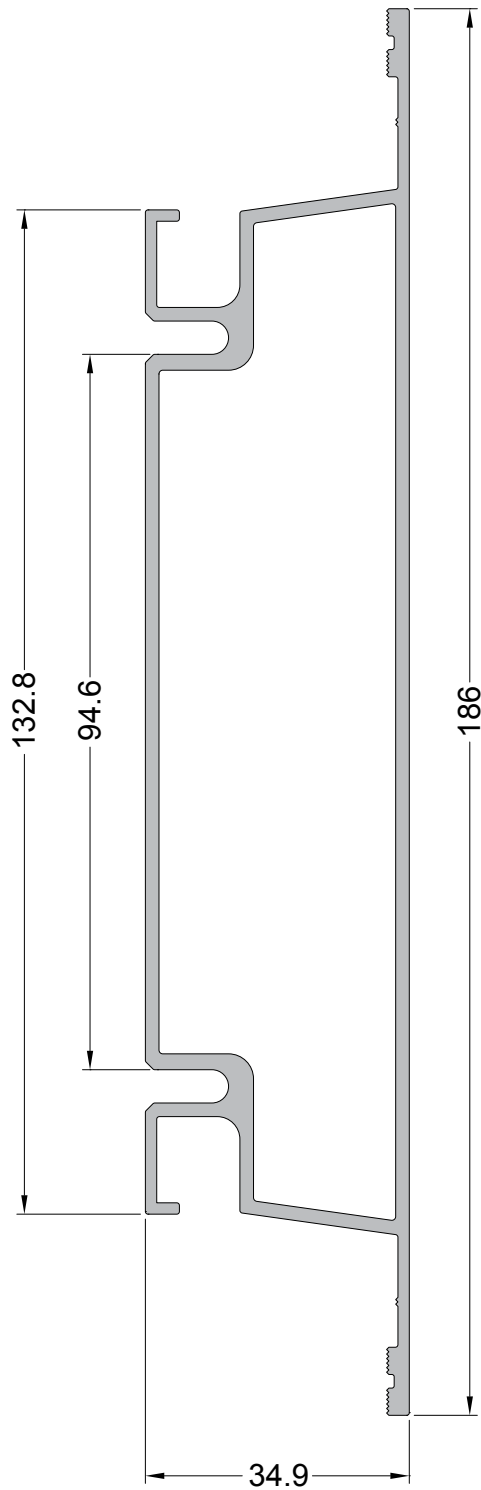

CX-3116  
1,420 Kg/m  
Travessa

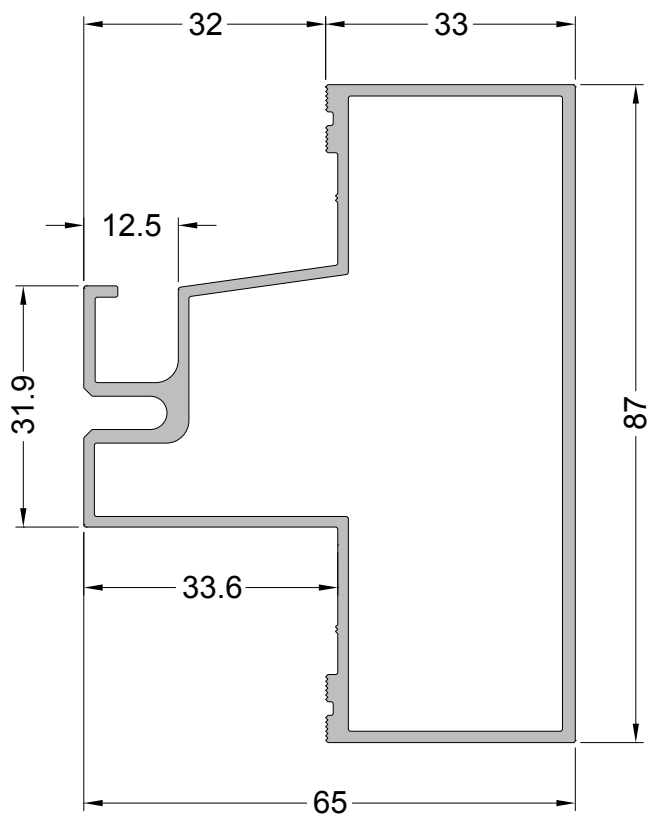

CX-3117  
0,963 Kg/m  
Travessa

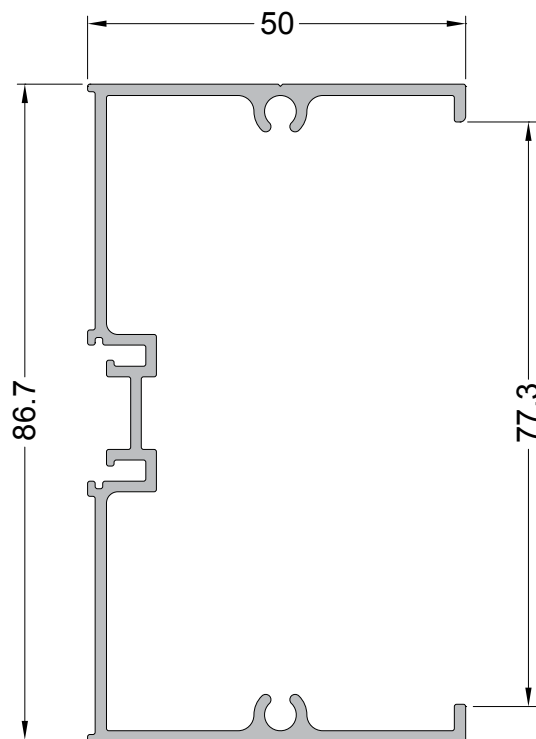

CX-3118  
0,372 Kg/m  
Tampa da Travessa

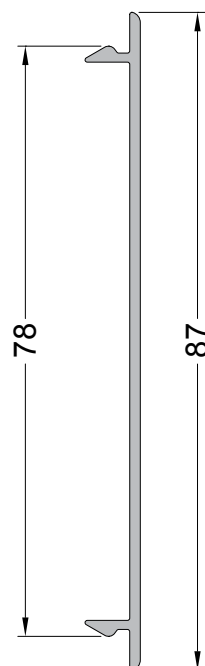

ALG-2028  
2,132 Kg/m  
Brise Decorativo

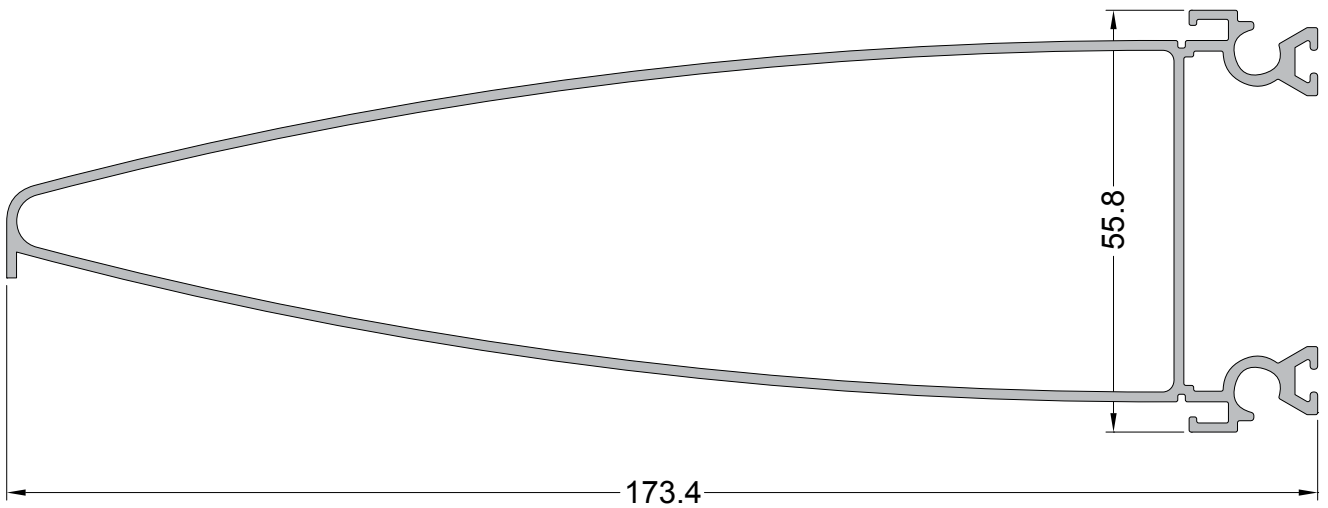

ALG-2031  
1,694 Kg/m  
Luva de Brise

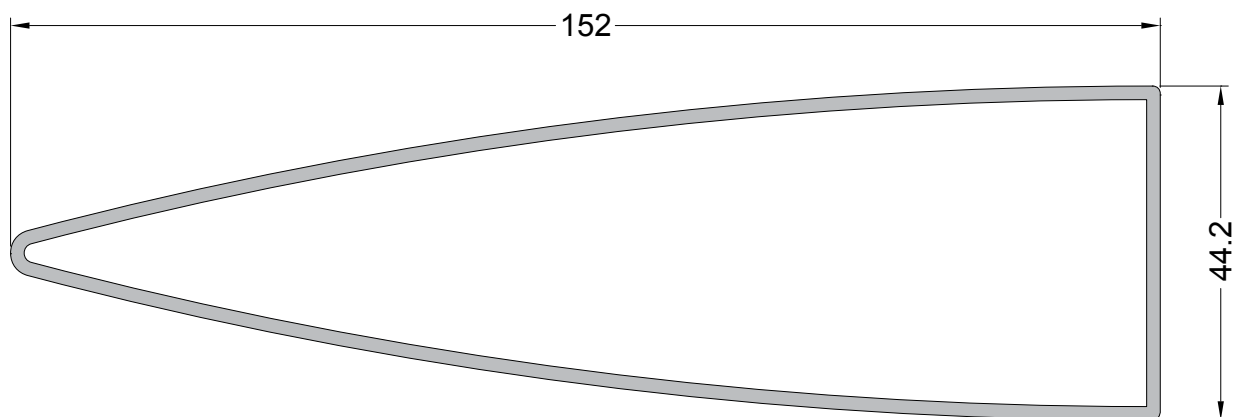



CX-3247  
1,611 Kg/m  
Brise

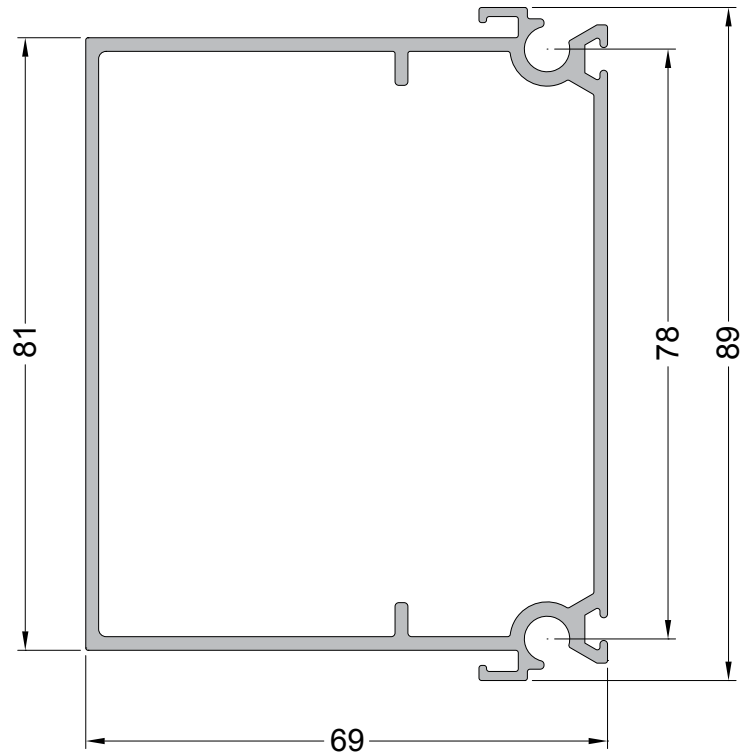

ALG-2012  
1.888 Kg/m  
Travessa

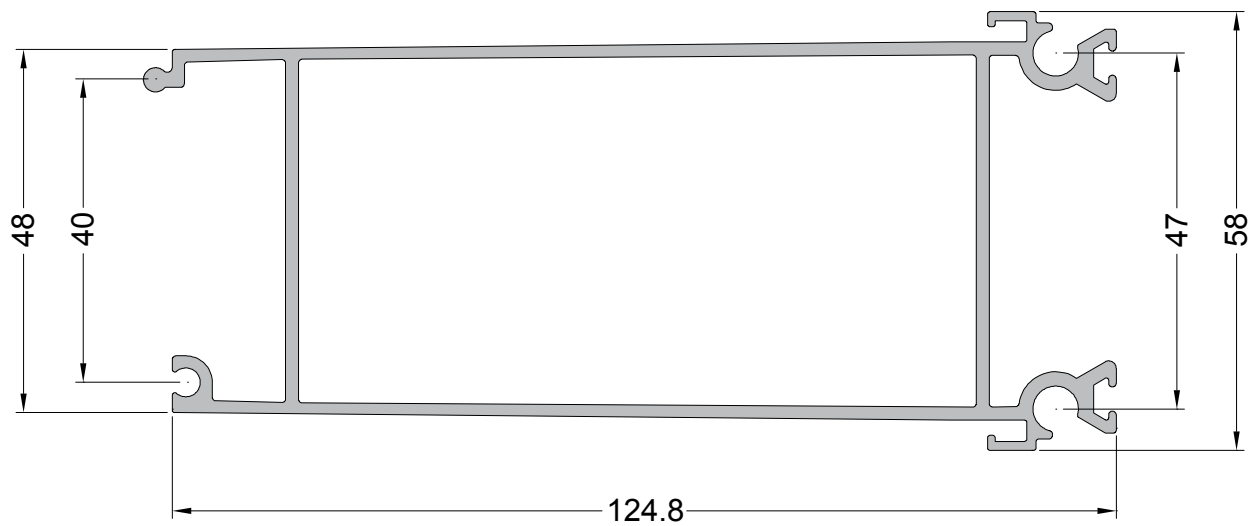

ALG-2013  
0,634 Kg/m  
Folha

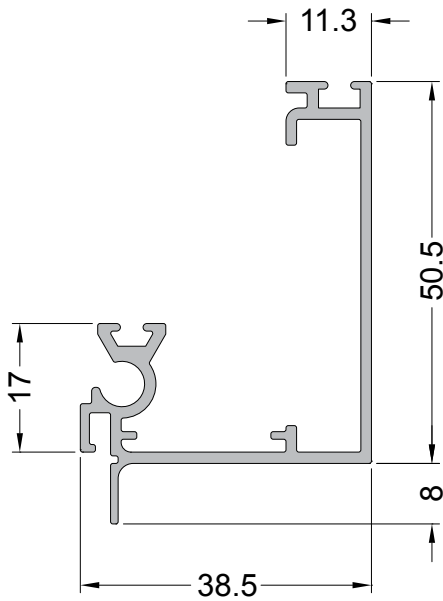

ALG-2014  
0,794 Kg/m  
Folha

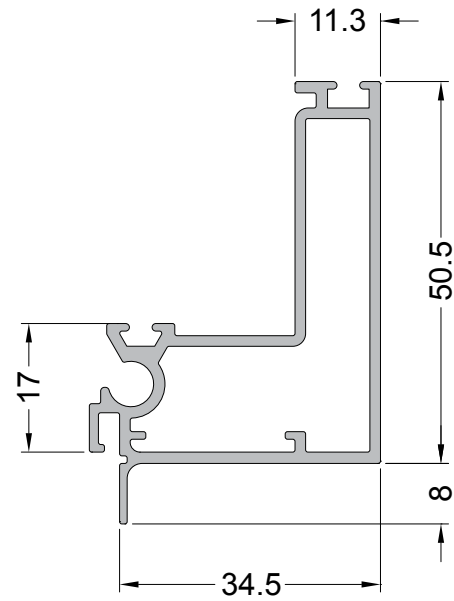

ALG-2017  
0,766 Kg/m  
Folha

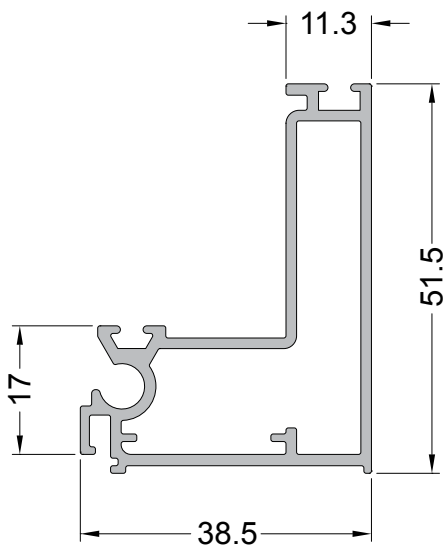

ALG-2016  
0,612 Kg/m  
Folha

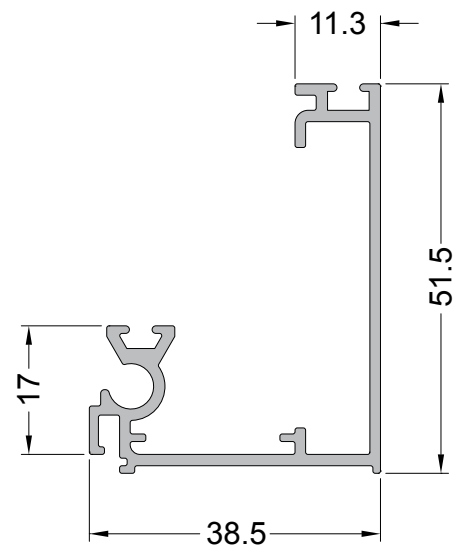

ALG-2026  
0,759 Kg/m  
Folha Fixa

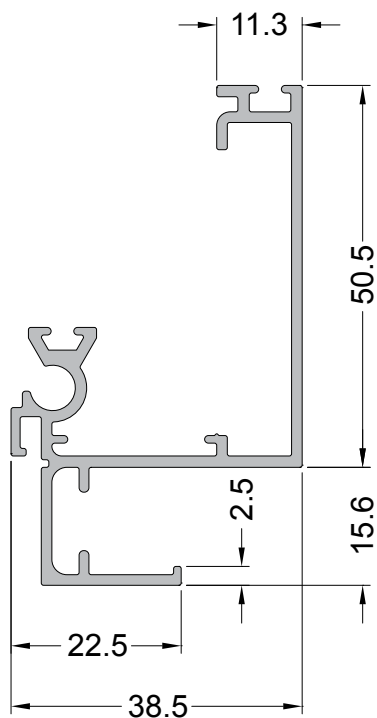

ALG-2027  
0,917 Kg/m  
Folha Móvel

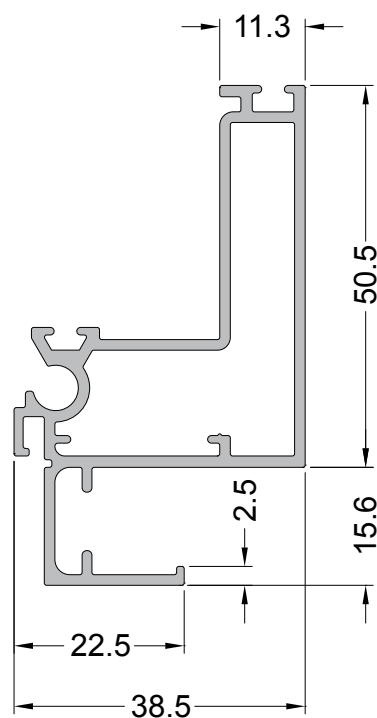

ALG-2037  
0,709 Kg/m  
Folha

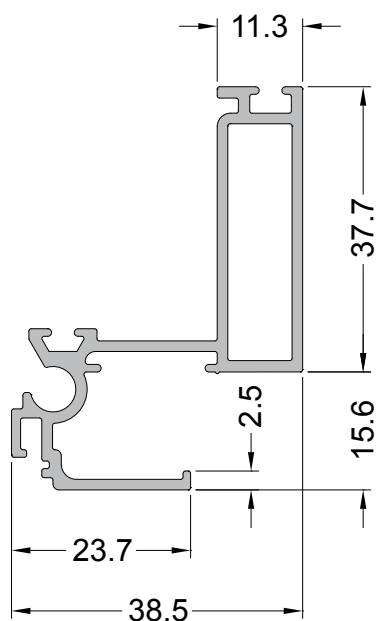

ALG-2015  
0,466 Kg/m  
Folha

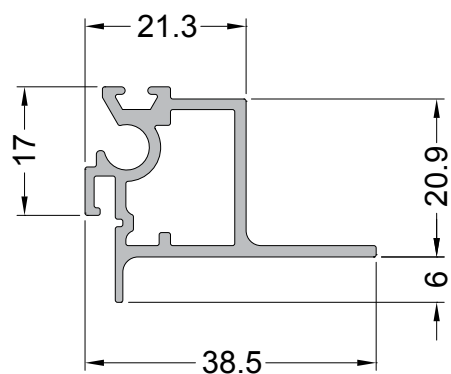

ALG-47602

0,805 Kg/m

Folha

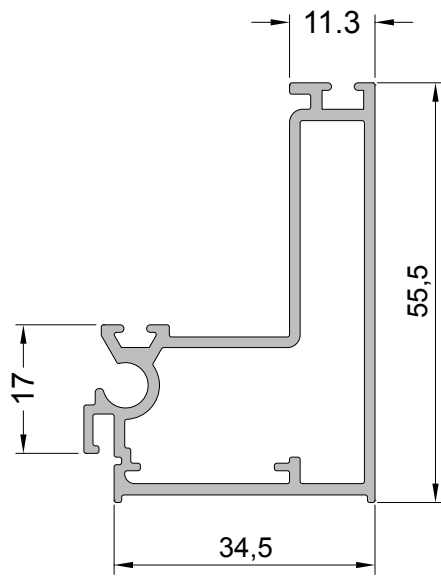

ALG-47601

1,011 Kg/m

Folha

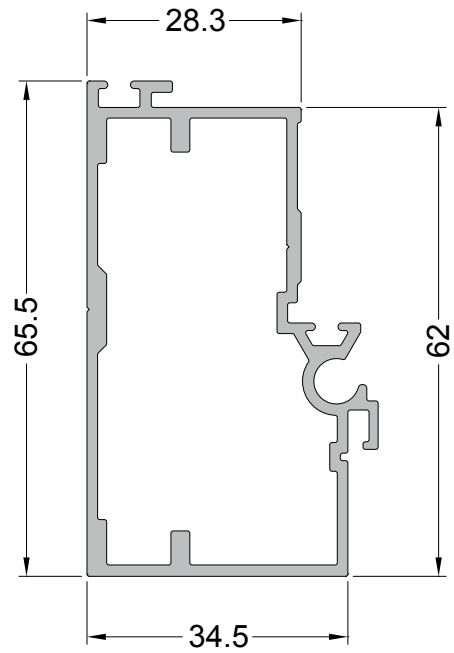

ALG-47603

0,836 Kg/m

Folha VHB

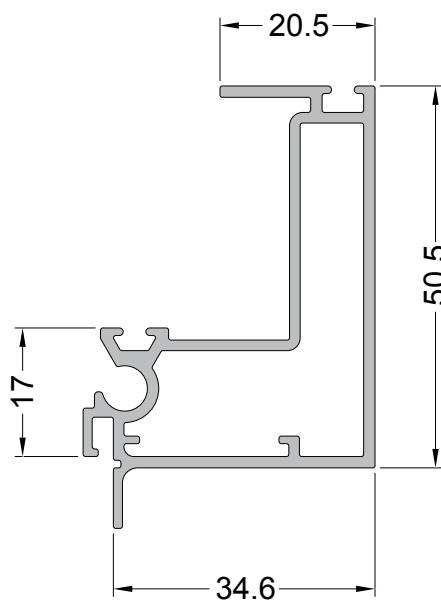

ALG-47604

0,803 Kg/m

Folha SSG

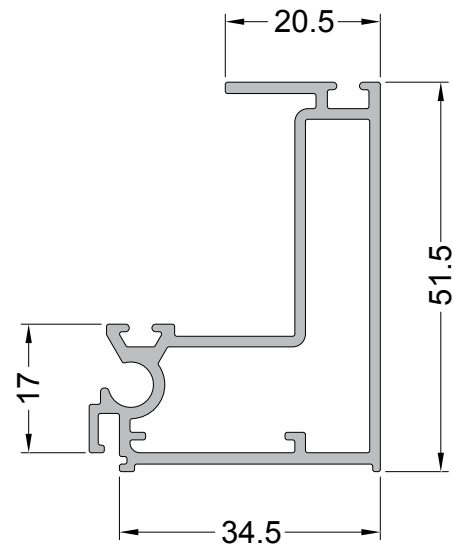

ALG-2035

0,713 Kg/m

Folha para Veneziana

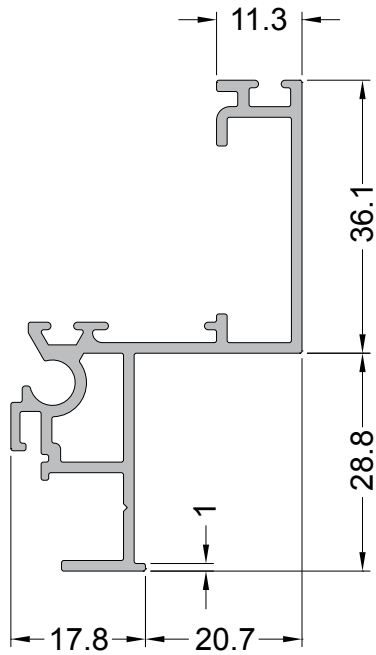

ALG-2036

0,324 Kg/m

Veneziana

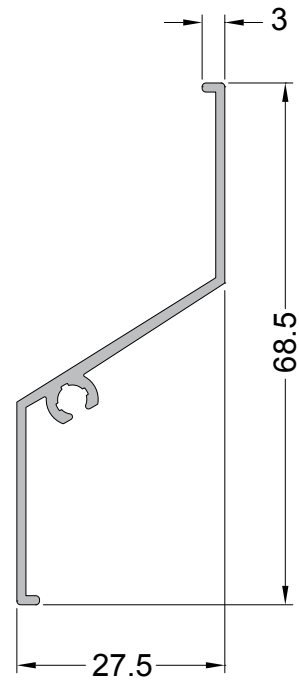

ALG-2009  
0,738 Kg/m  
Luva p/ Travessa

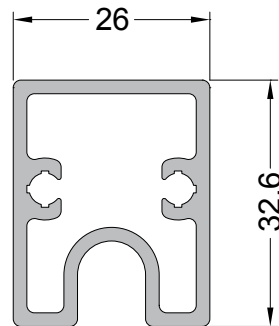

ALG-2030  
0,718 Kg/m  
Luva p/ Travessa

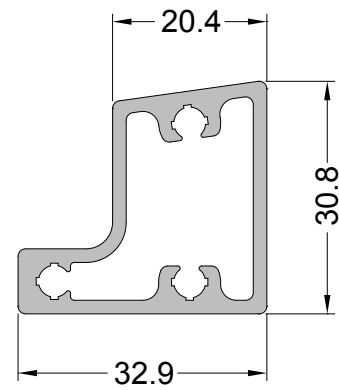

ALG-2043  
1,334 Kg/m  
Luva Central

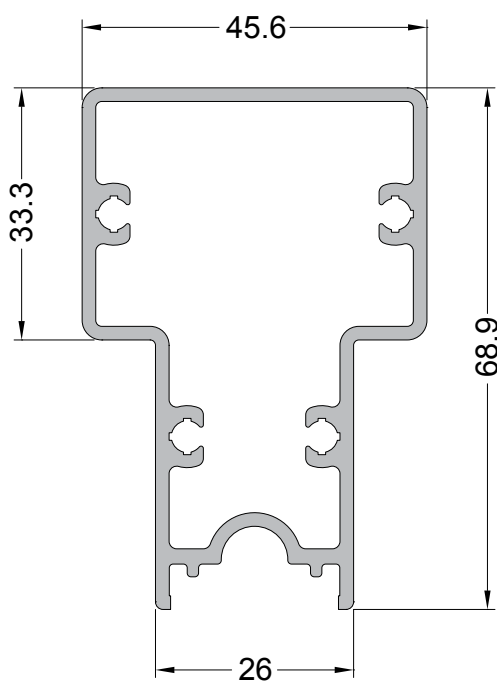

ALG-2046

1,656 Kg/m

Luva Central

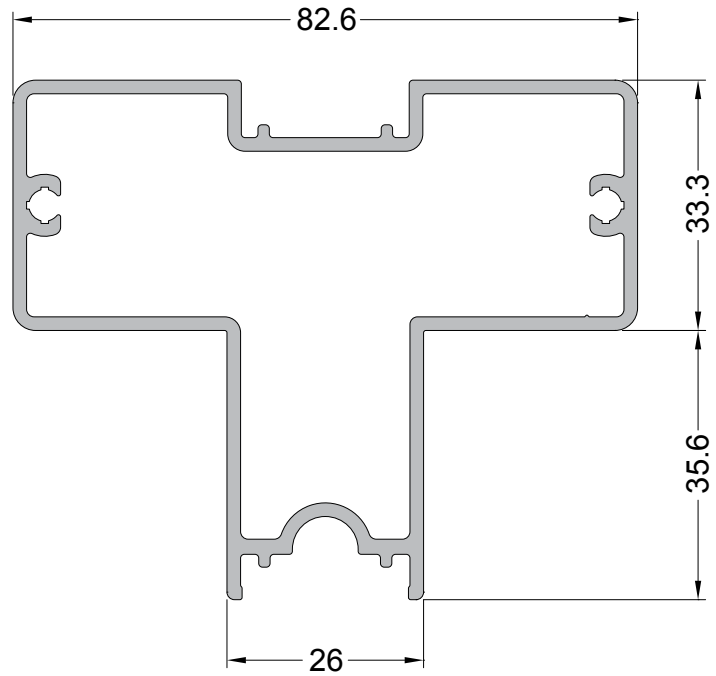

ALG-2049

1,994 Kg/m

Luva Central

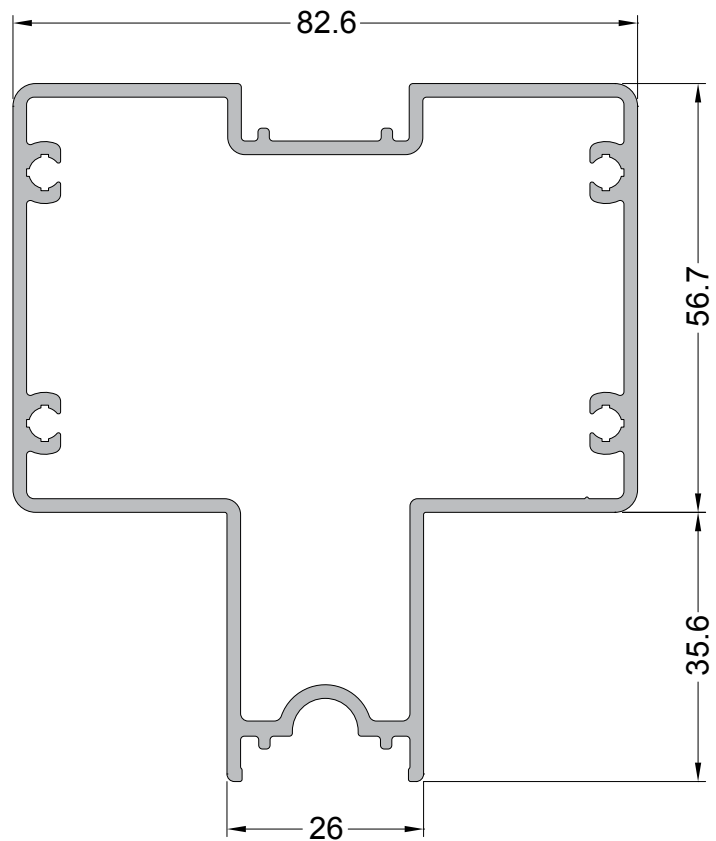

ALG-2001  
1,940 Kg/m  
Luva Central

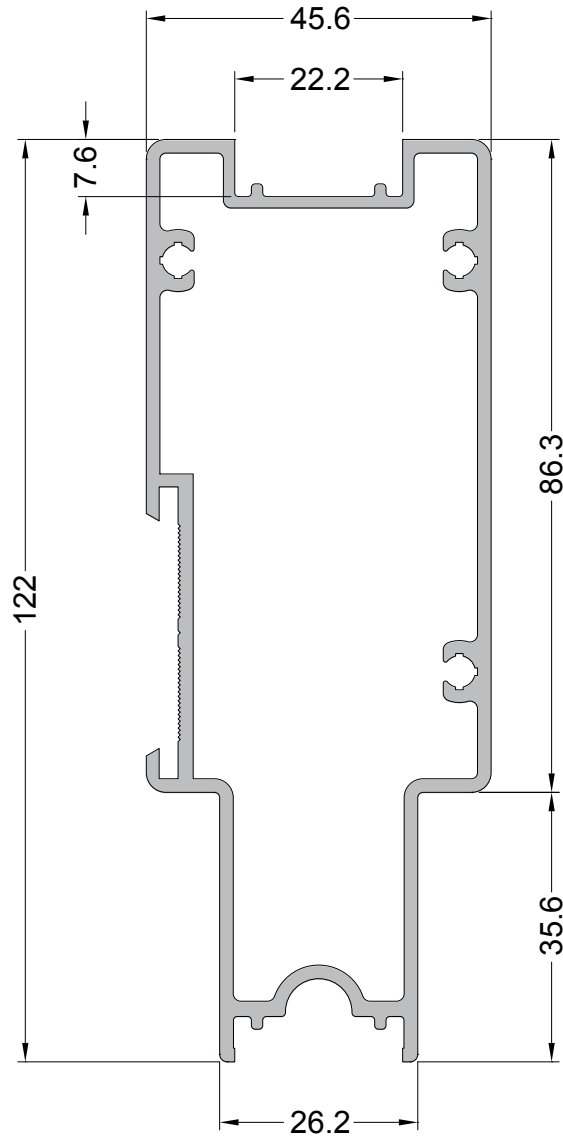



ALG-2042  
2,296 Kg/m  
Luva Central

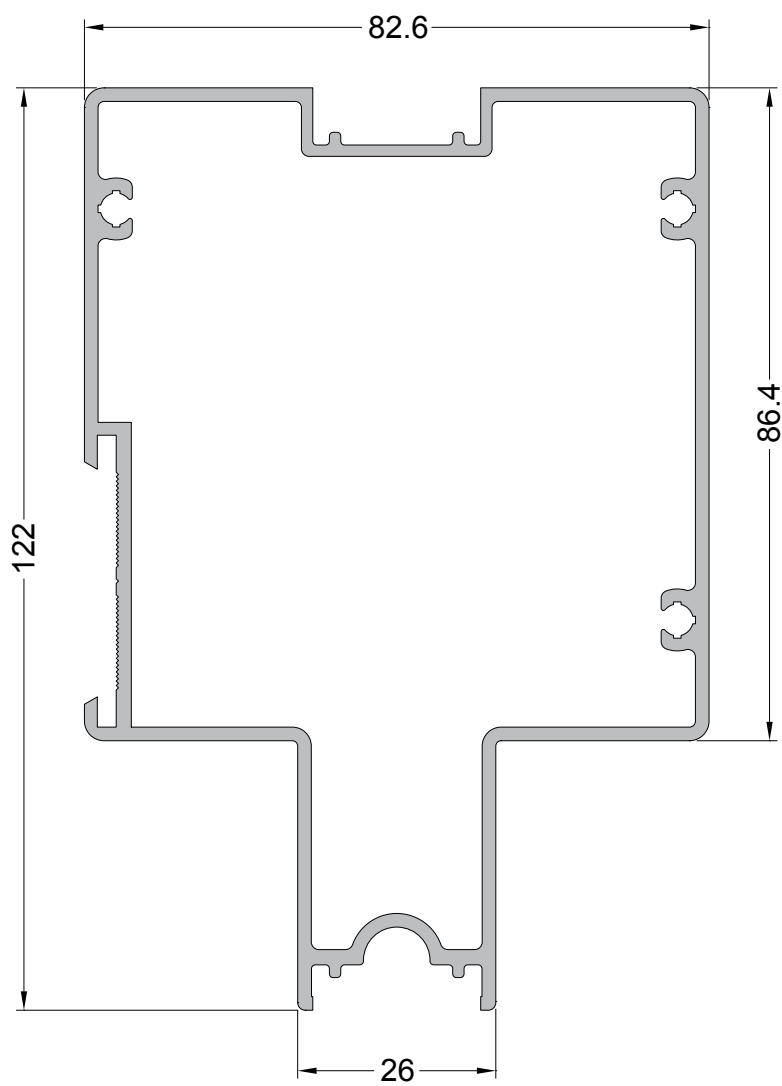

ALG-2053  
2.832 Kg/m  
Luva Canto

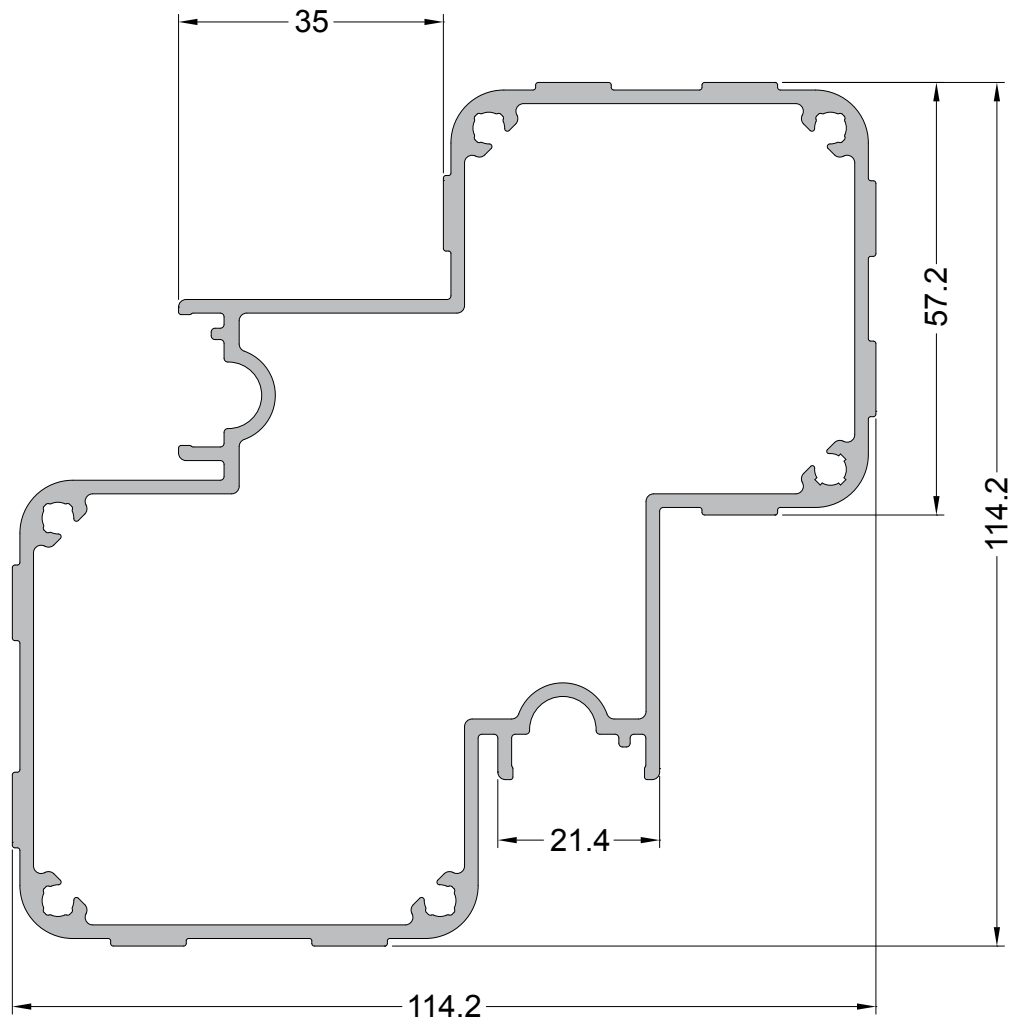

ALG-2033

1,914 Kg/m

Luva P/ Coluna em Ângulo

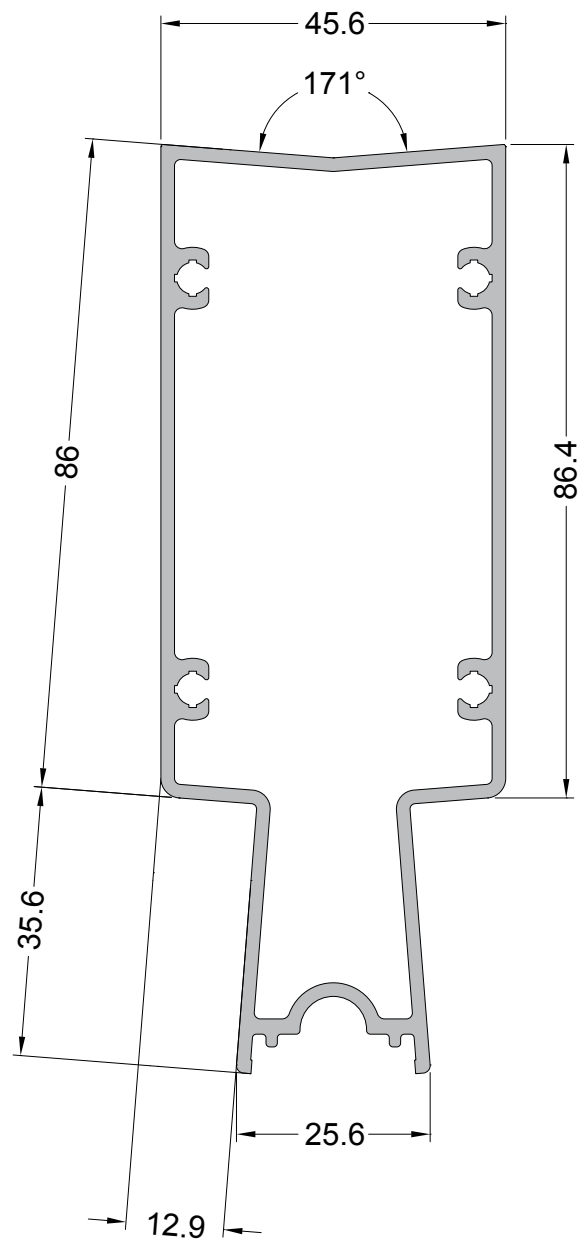

ALG-84701

1,535 Kg/m

Luva Lateral

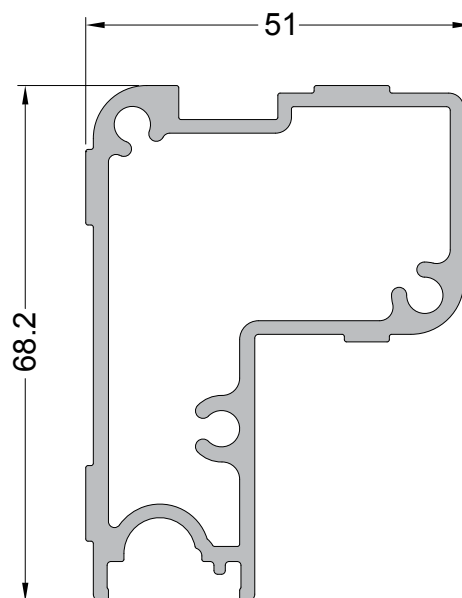

ALG-2073  
3,709 Kg/m  
Ancoragem

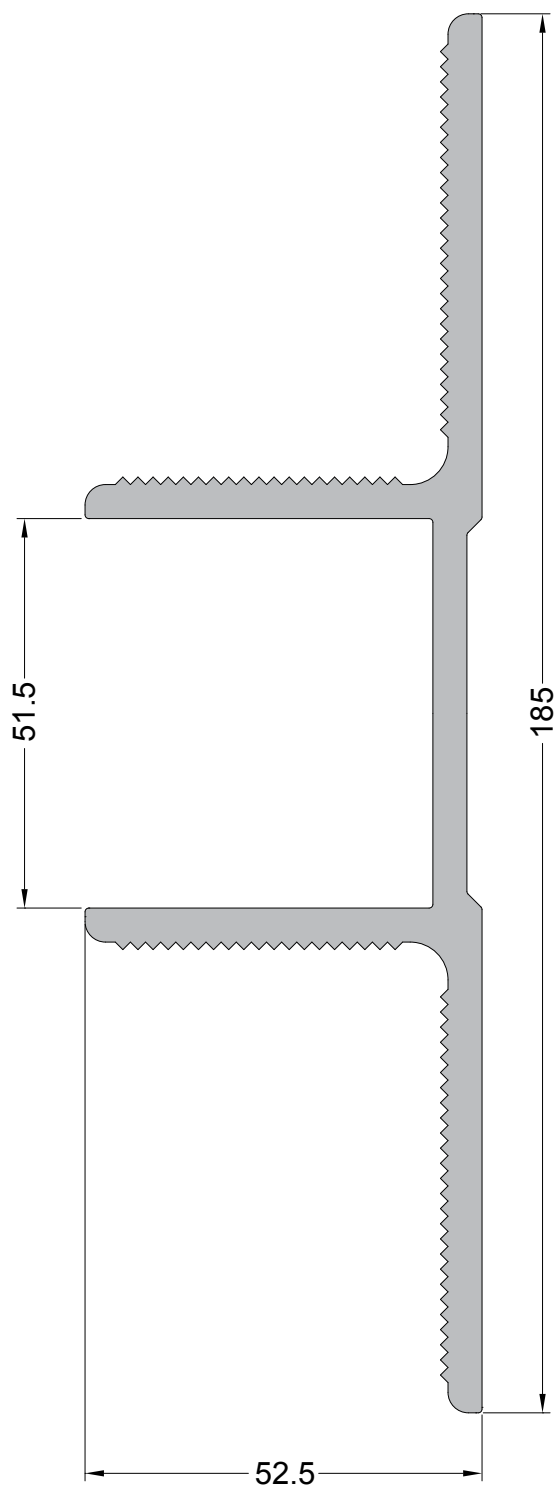

ALG-2066  
5,486 Kg/m  
Ancoragem

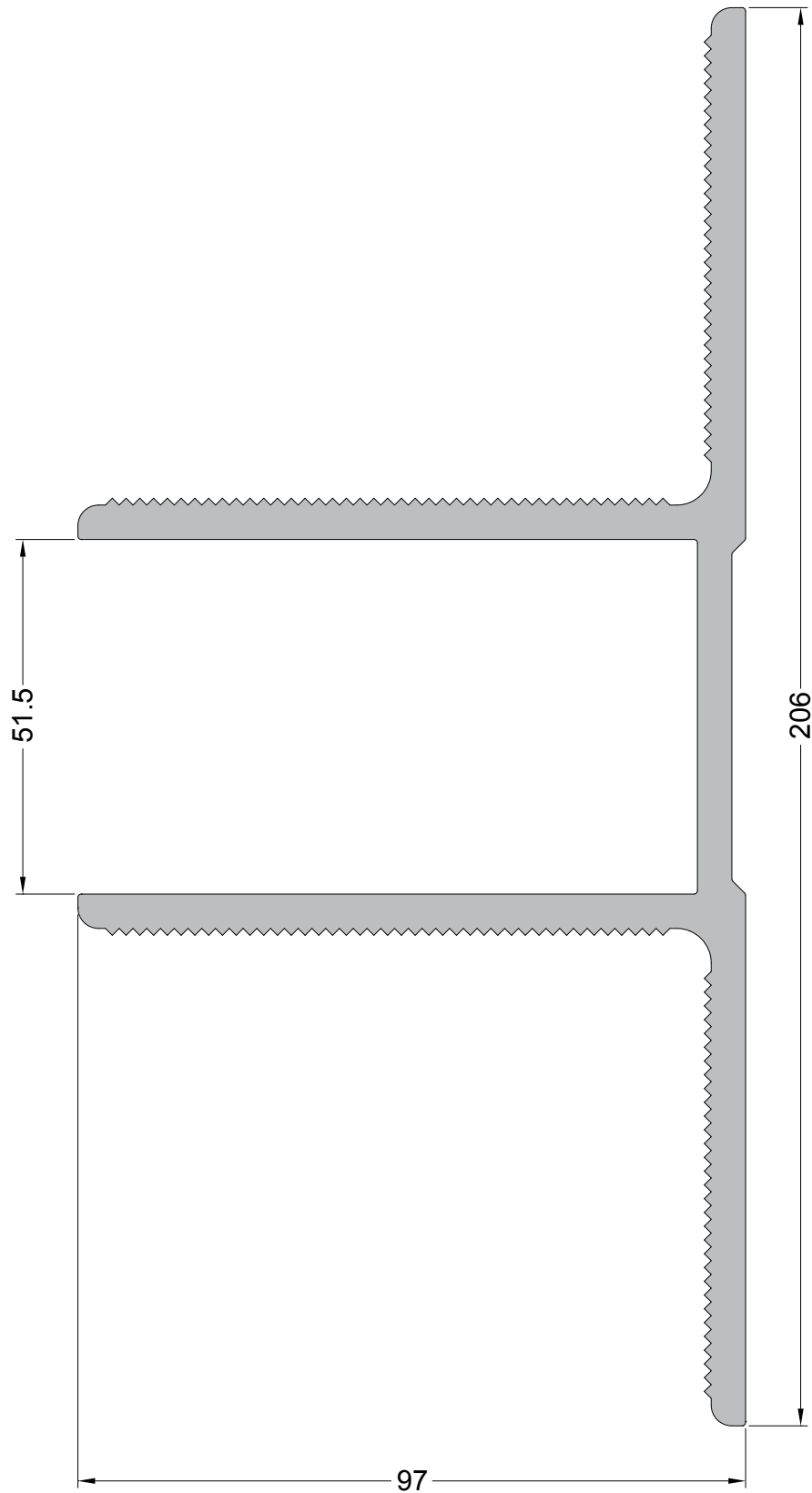

ALG-2051  
4,599 Kg/m  
Ancoragem Central

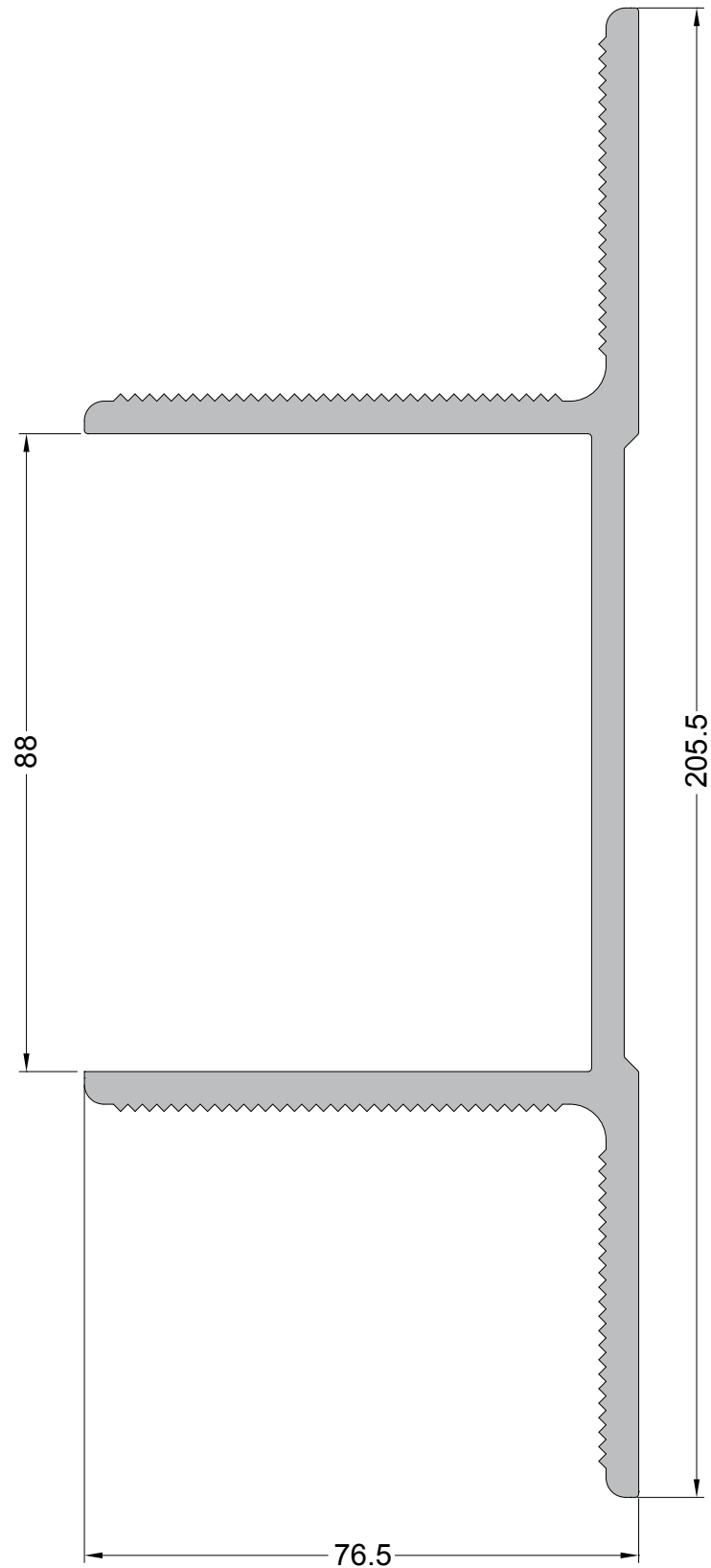

ALG-2018  
0,194 Kg/m  
Presilha

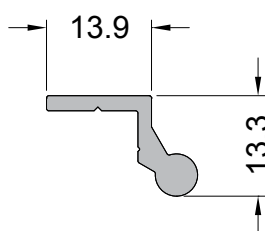

ALG-2059  
0,569 Kg/m  
Arremate Peitoril

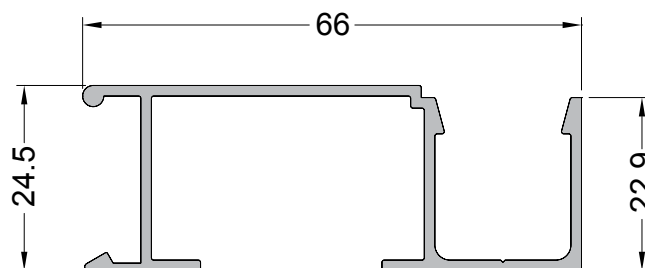

ALG-2064  
0,374 Kg/m  
Presilha de Apoio

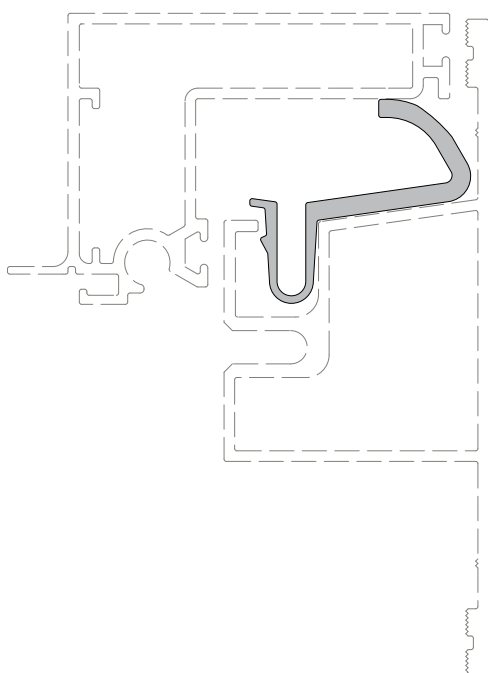

ALG-2019  
0,361 Kg/m  
Arremate Peitoril

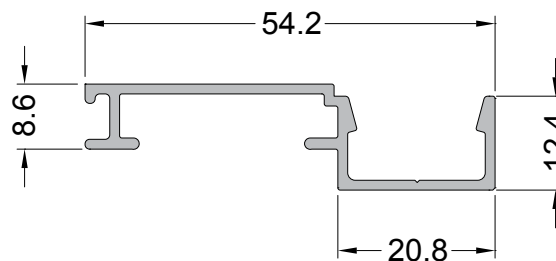

ALG-2061  
0,117 Kg/m  
Tampa do Arremate Peitoril

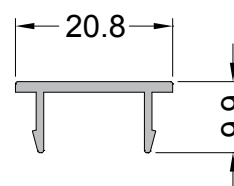



CX-3153  
0,777 Kg/m  
Arremate

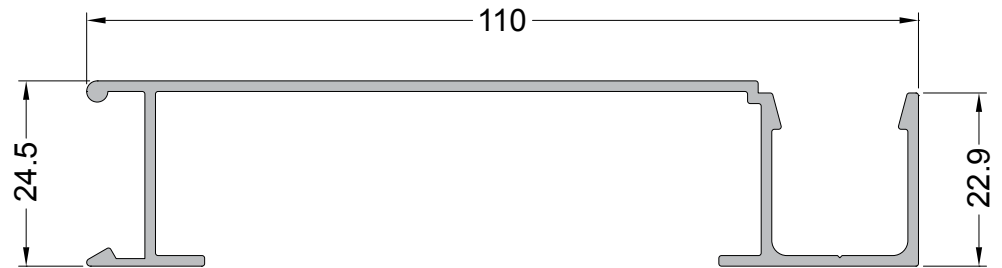

ALG-2058  
0,429 Kg/m  
Arremate Coluna

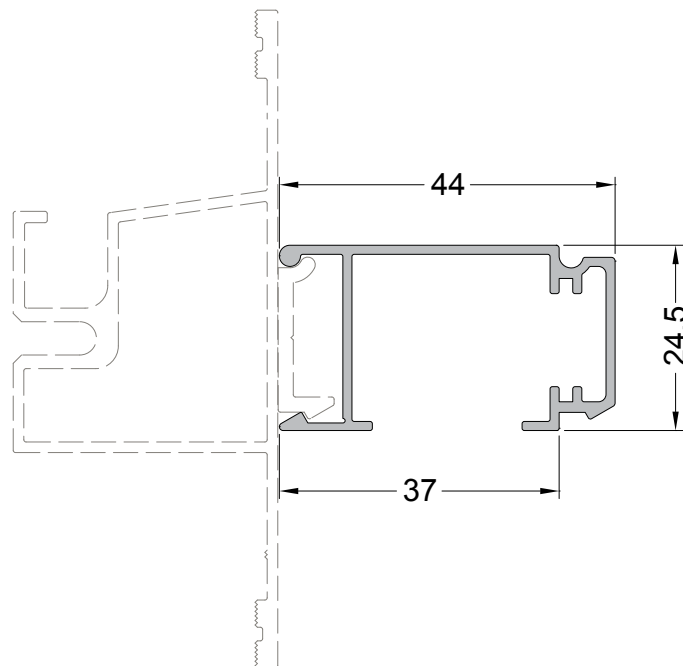

ALG-2020  
0,431 Kg/m  
Arremate

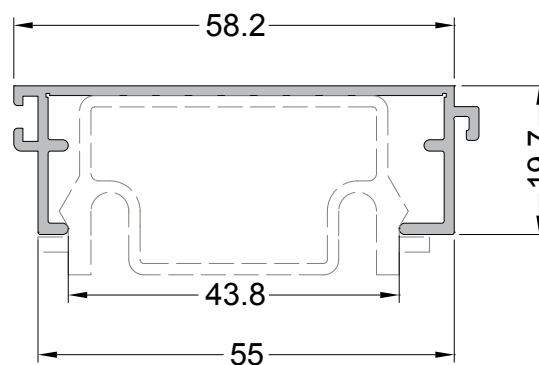

ALG-2021  
0,575 Kg/m  
Arremate entre Coluna

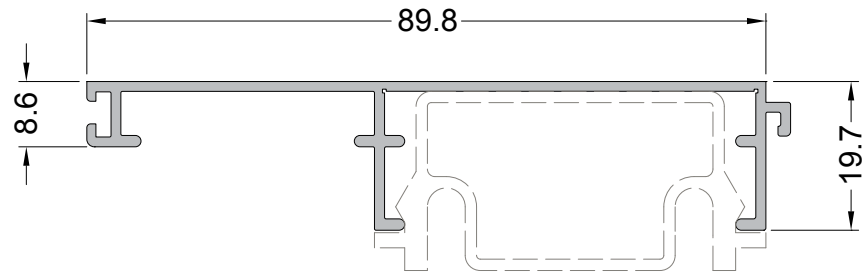

ALG-2057  
0,150 Kg/m  
Presilha

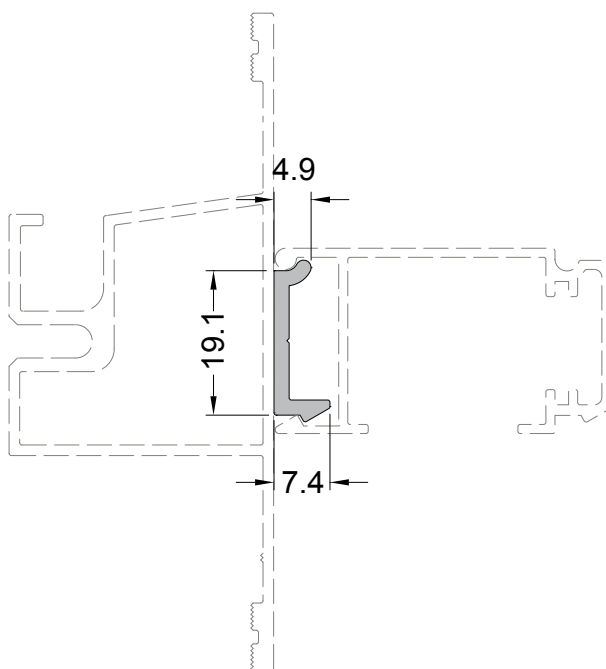

ALG-2065  
0,242 Kg/m  
Arruela Dentada

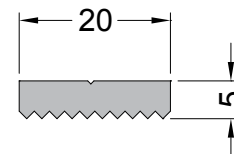

RB-003  
1.971 Kg/m  
Coluna

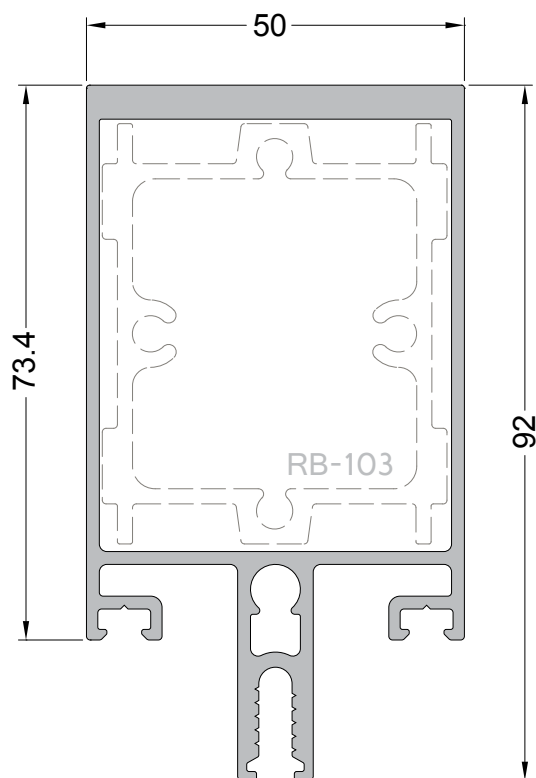

RB-004  
2.119 Kg/m  
Coluna

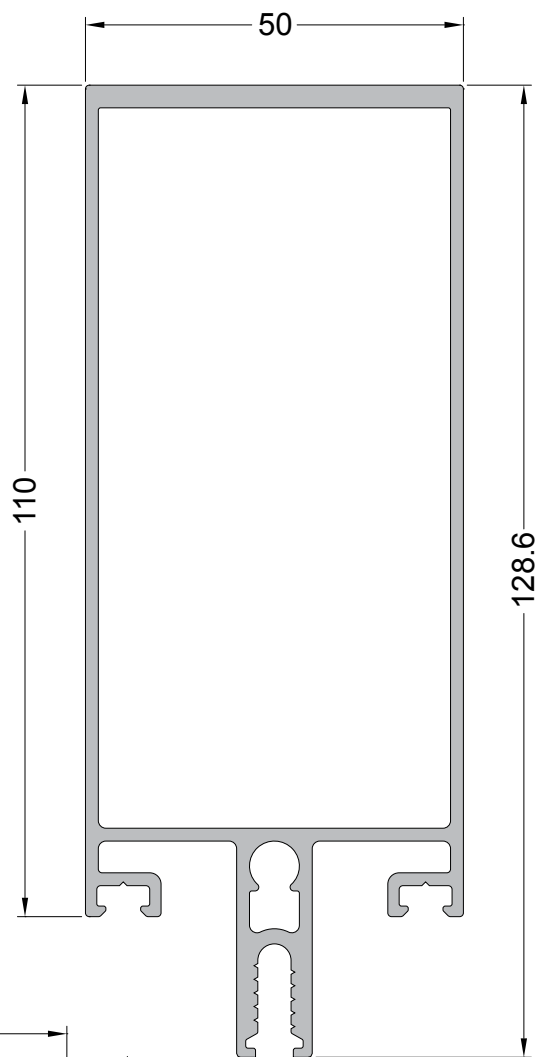

RB-011  
0.359 Kg/m  
Contra Tampa

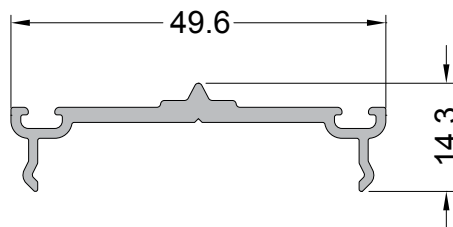

FC-542  
0.350 Kg/m  
Tampa

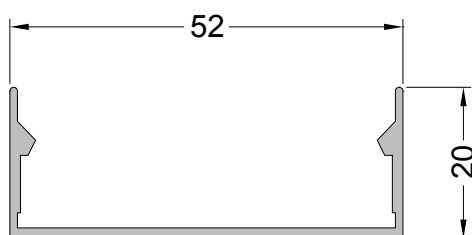

RB-023  
1.501 Kg/m  
Travessa

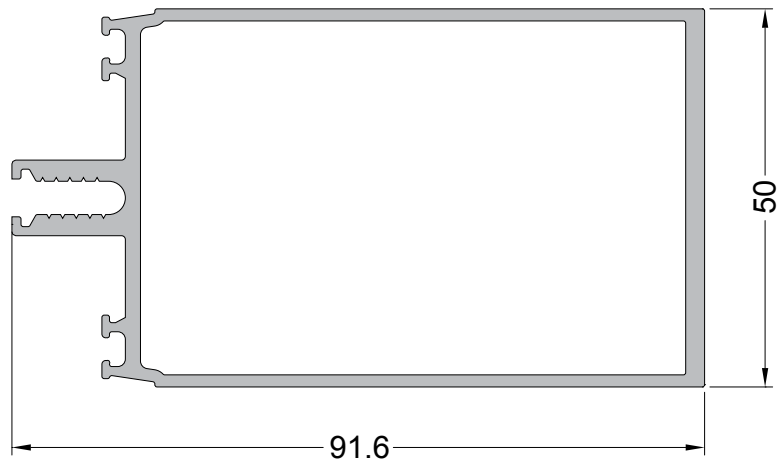

RB-024  
1.889 Kg/m  
Travessa

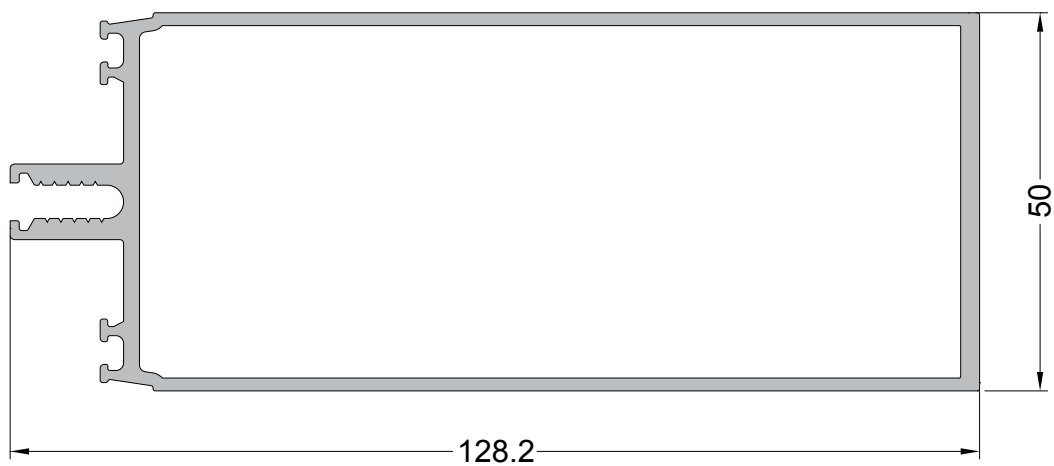

RB-80801  
1.006 Kg/m  
Brise (Tampa)

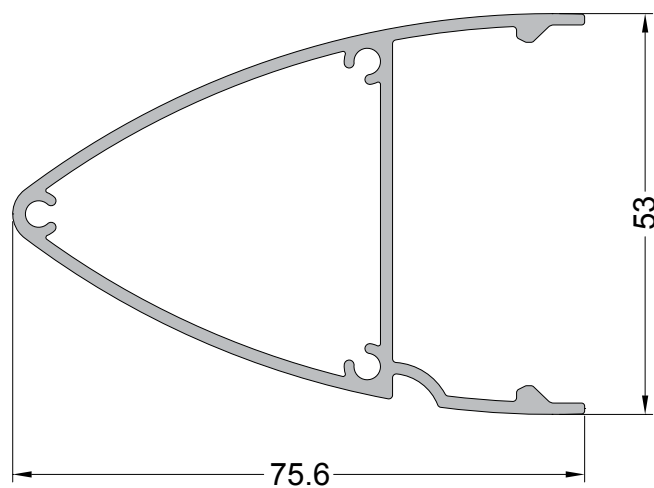

RB-404  
0.487 Kg/m  
Tampa

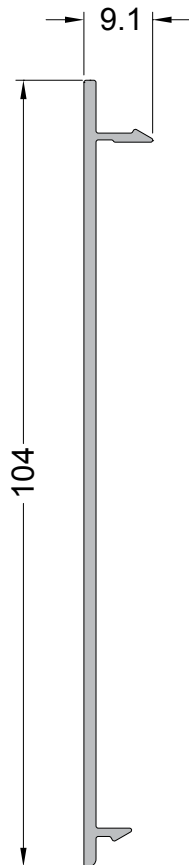

RB-034  
1.705 Kg/m  
Meia Coluna

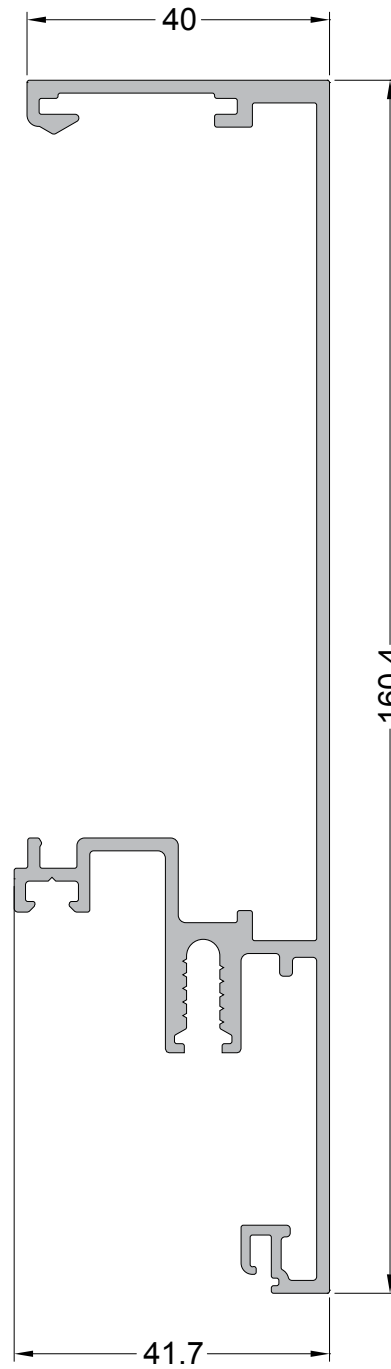

RB-006  
1.778 Kg/m  
Coluna

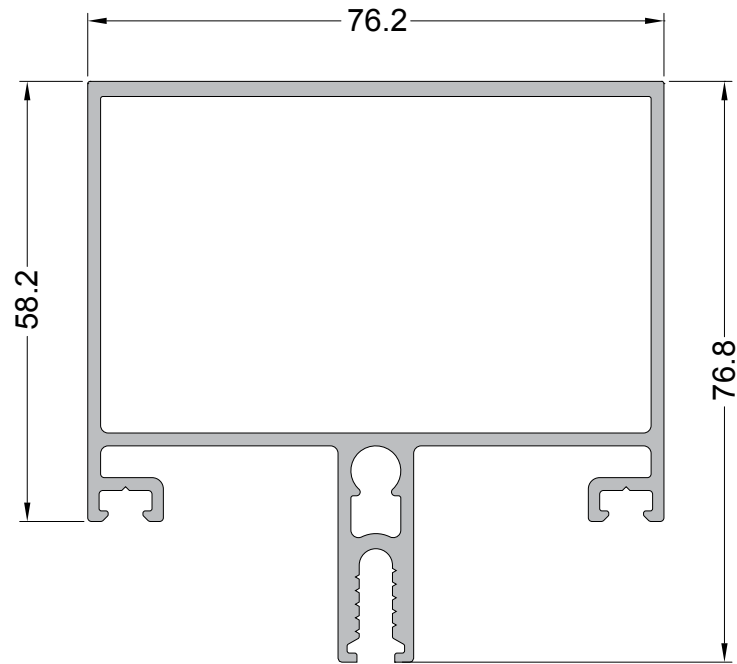

RB-007  
2.069 Kg/m  
Coluna

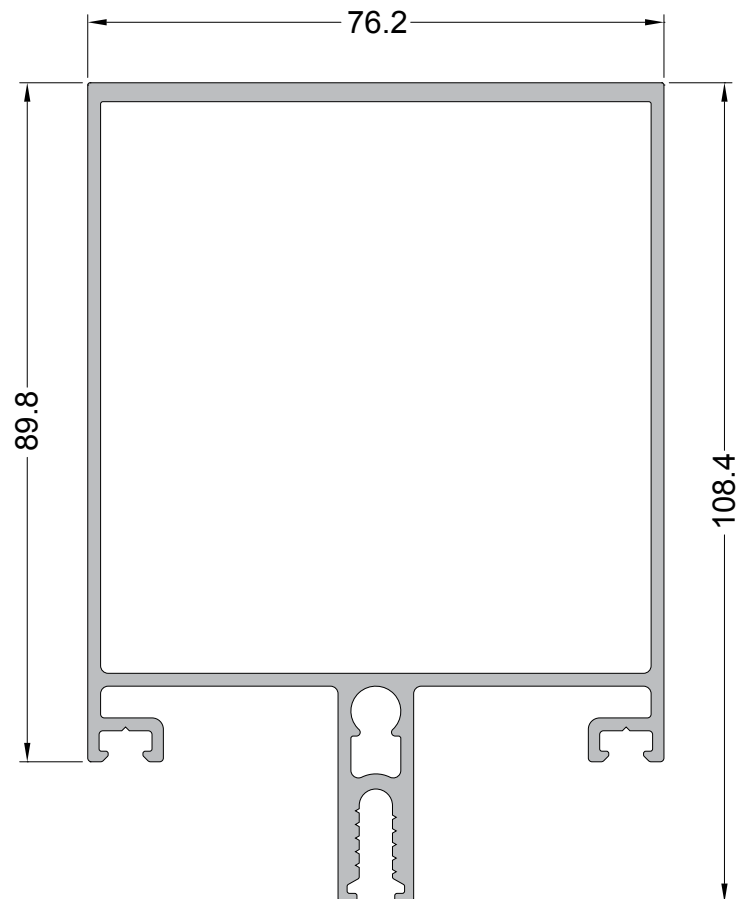

RB-015  
0.490 Kg/m  
Contra Tampa

RB-016  
0.598 Kg/m  
Contra Tampa

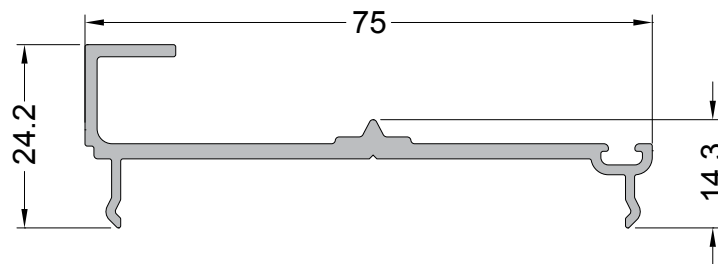
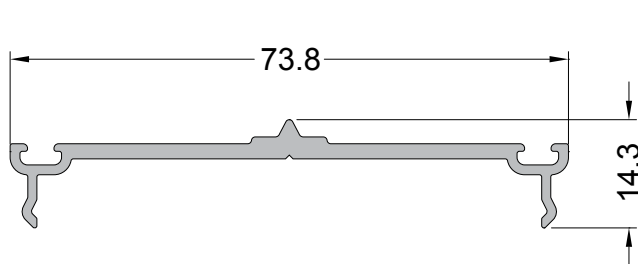

RB-041  
0.495 Kg/m  
Tampa

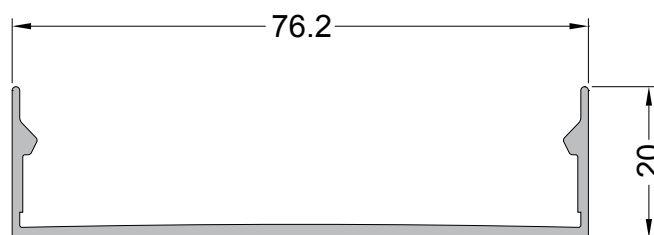

RB-042  
1.066 Kg/m  
Brise (Tampa)

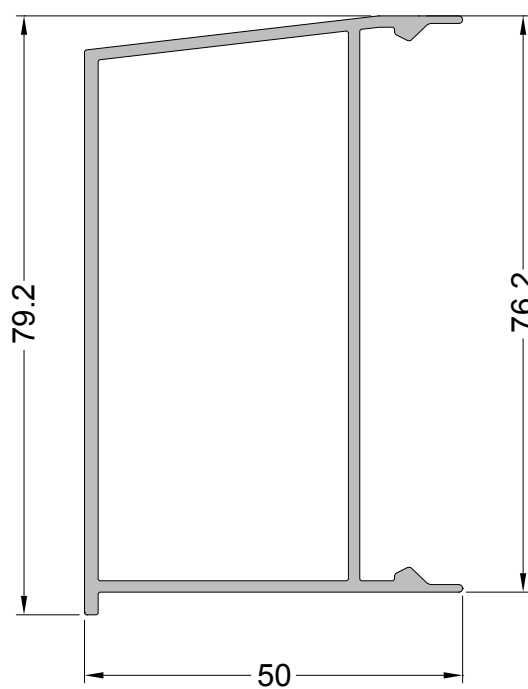

RB-026  
1.622 Kg/m  
Travessa

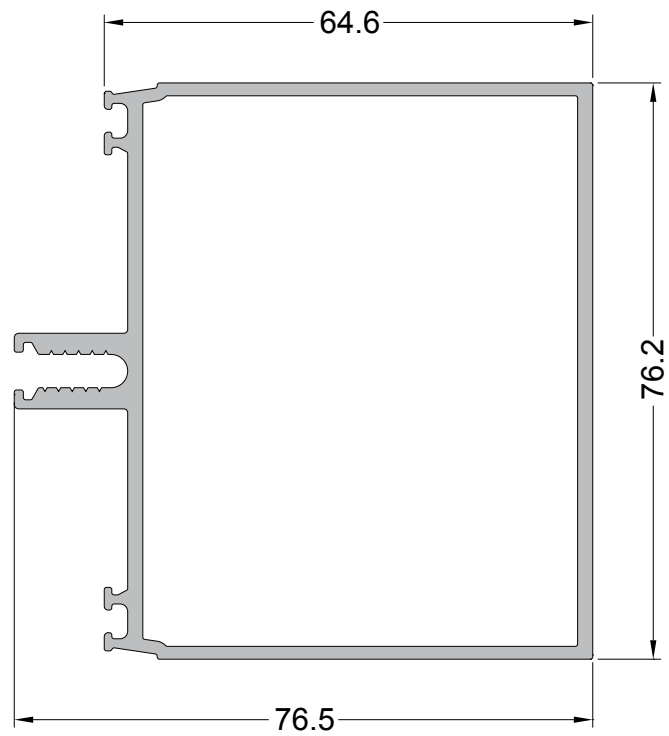

RB-027  
1.913 Kg/m  
Travessa

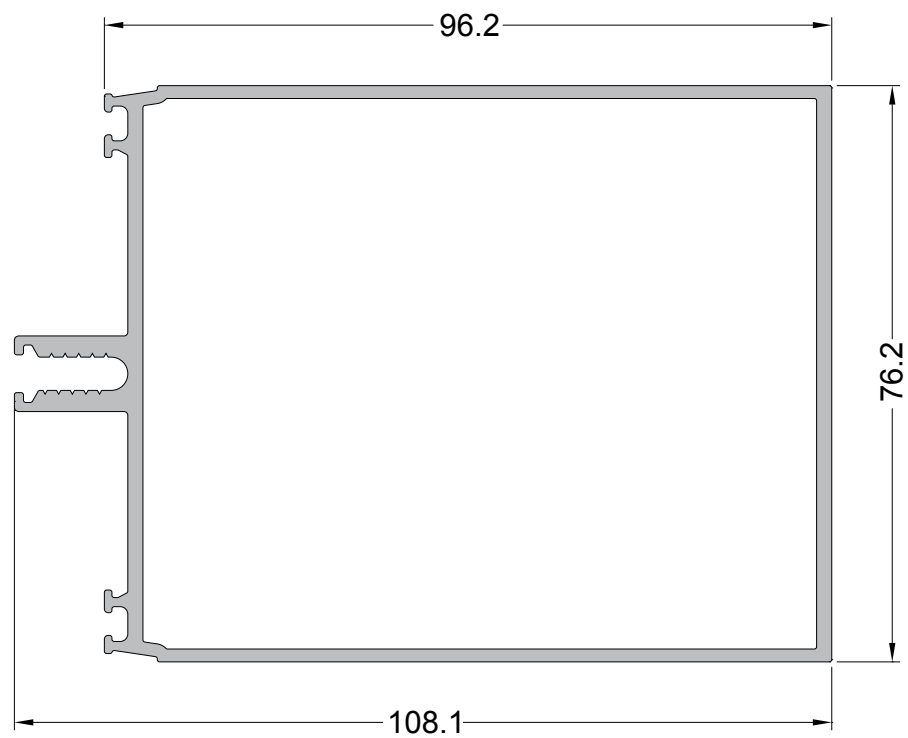



ALG-8005

1.114 Kg/m

Coluna

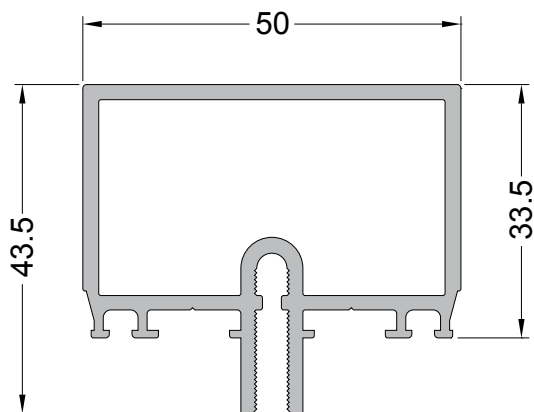

RB-47701

3.698 Kg/m

Coluna

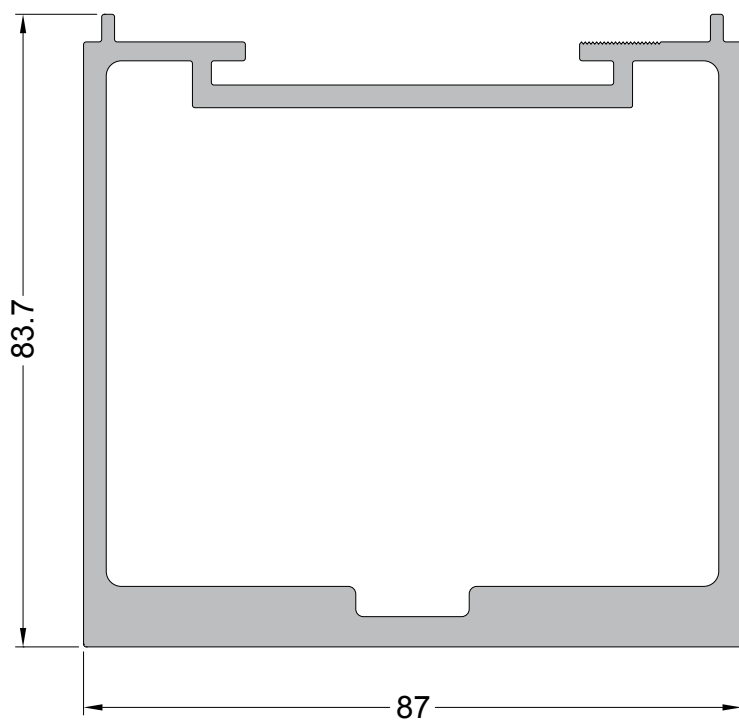

RB-76401

2.498 Kg/m

Coluna

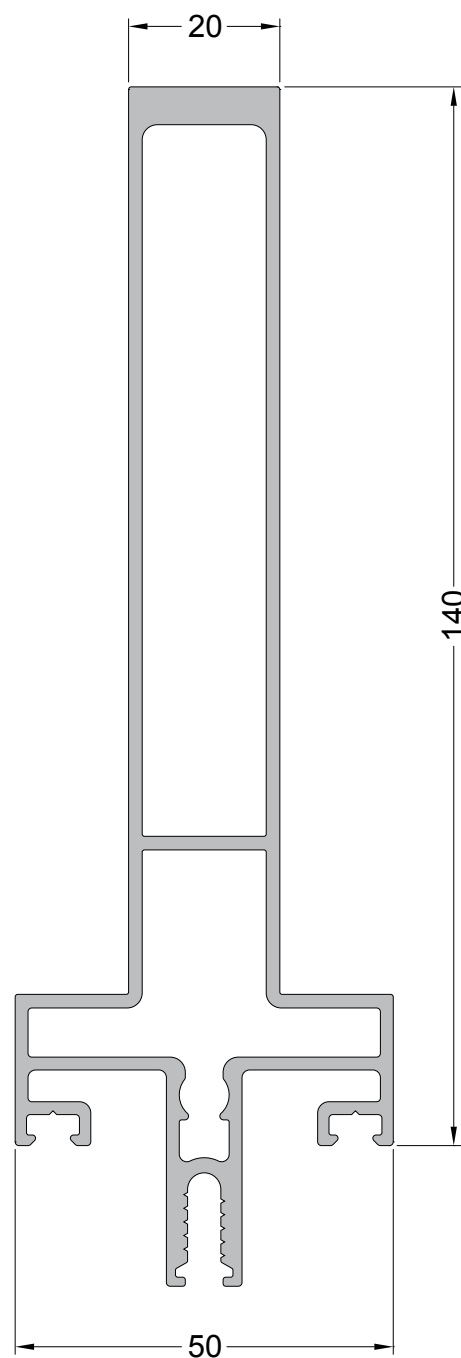

RB-26401  
2.385 Kg/m  
Travessa

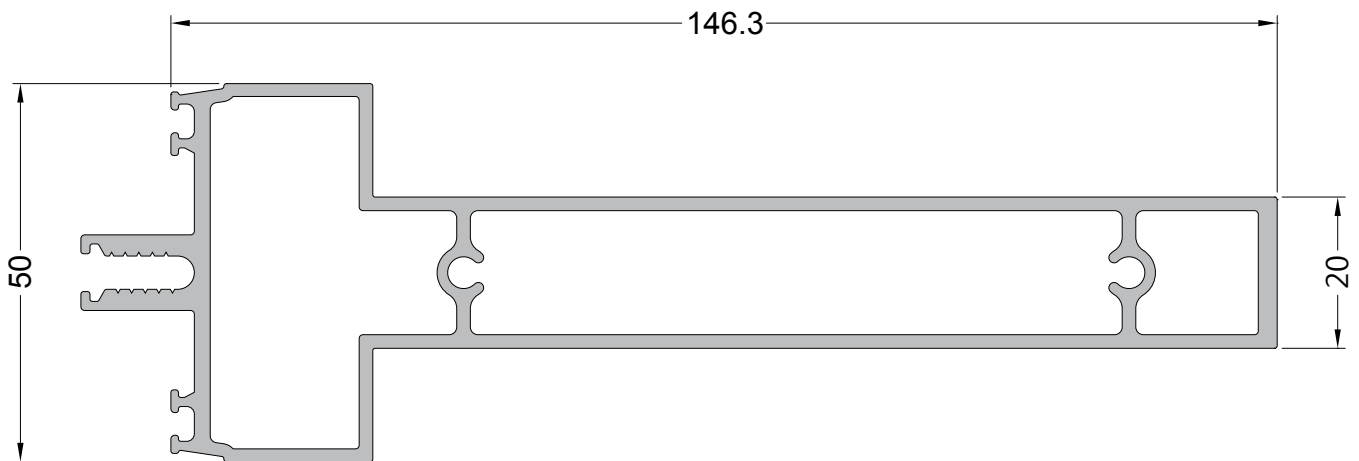

ALG-8004  
1.860 Kg/m  
Coluna

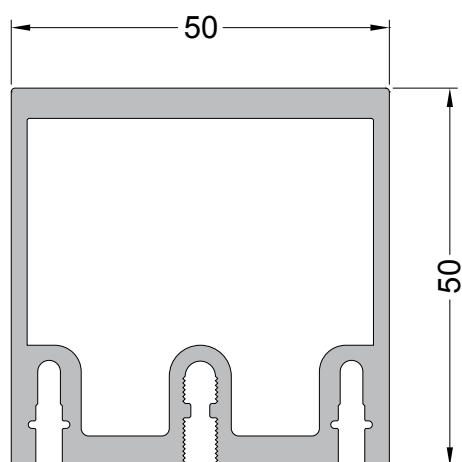

ALG-8000  
2.314 Kg/m  
Coluna

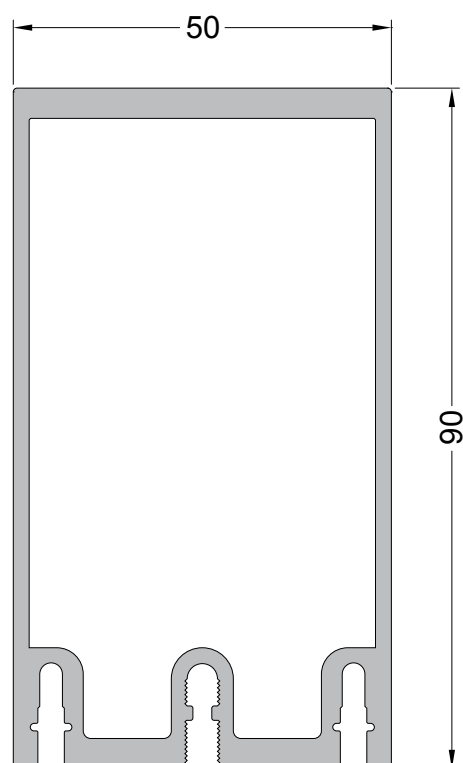

ALG-8002  
0.499 Kg/m  
Contra Tampa

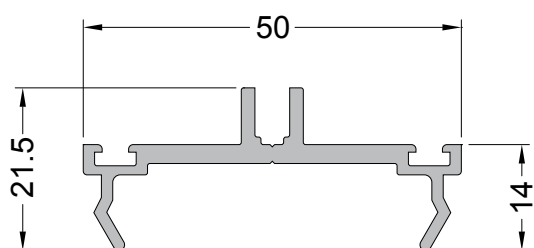

ALG-8001  
1.818 Kg/m  
Travessa

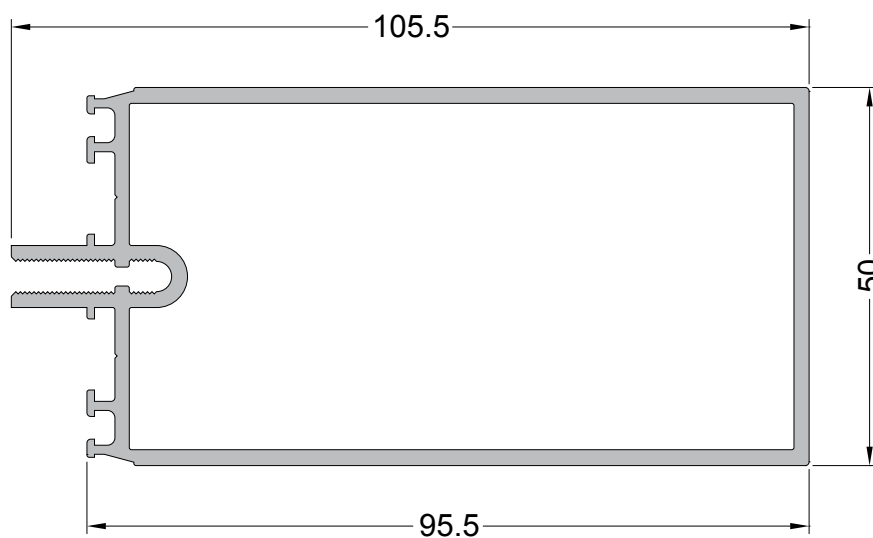

ALG-8003  
1.948 Kg/m  
Brise (Tampa)

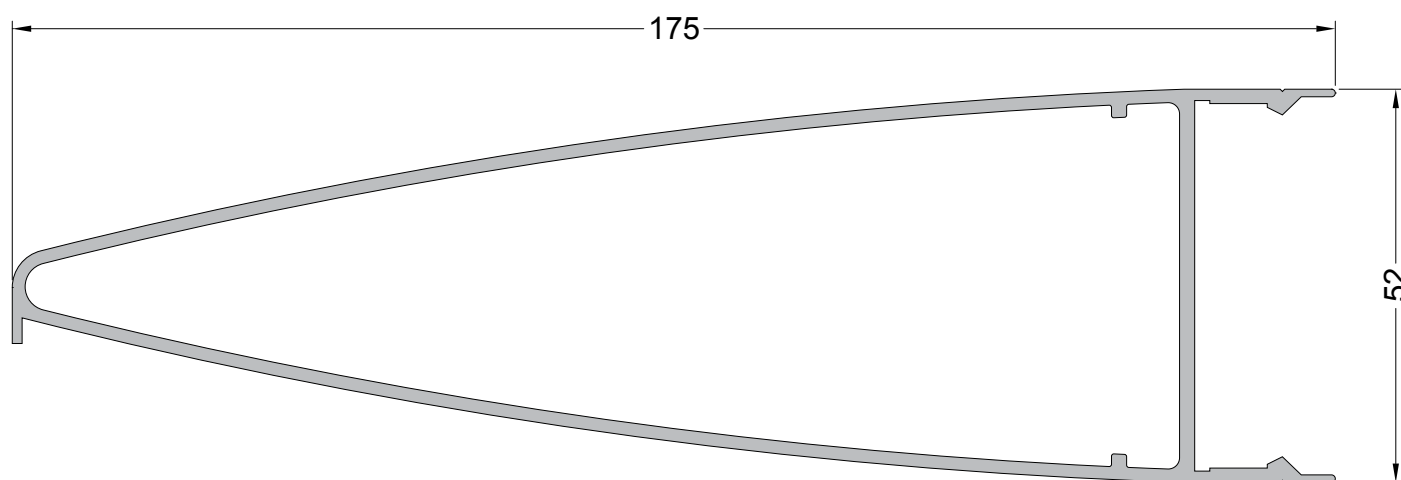

RB-052

1.080 Kg/m

Marco

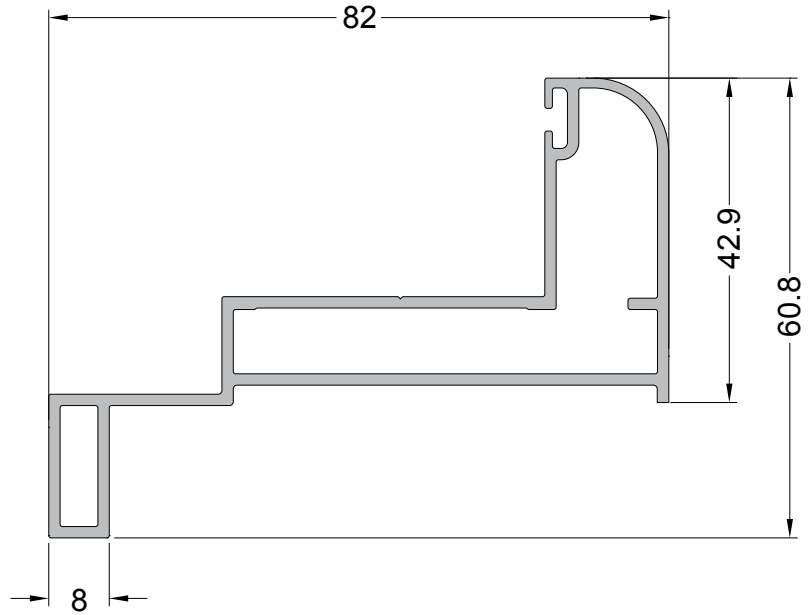

RB-051

0.897 Kg/m

Folha

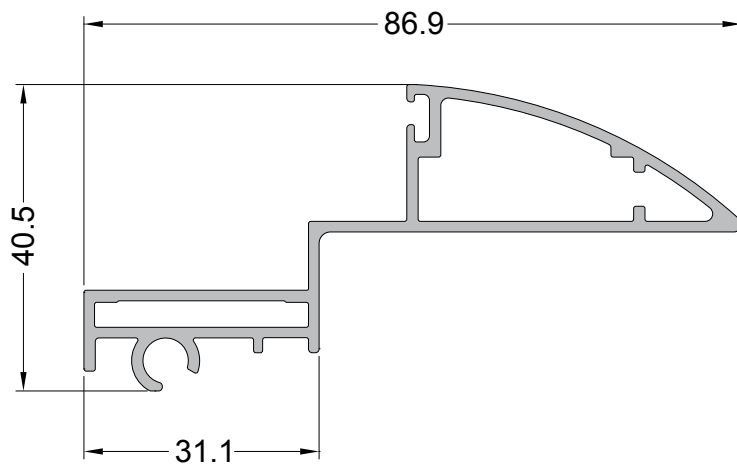

RB-201  
0.592 Kg/m  
Folha

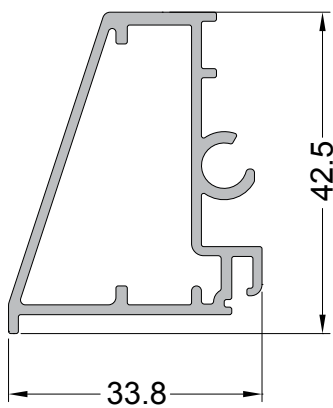

RB-203  
0.474 Kg/m  
Folha

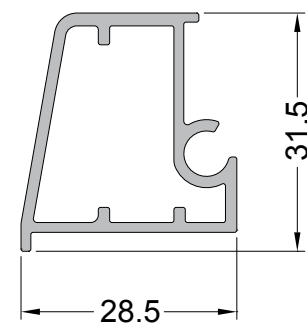

RB-204  
0.645 Kg/m  
Folha

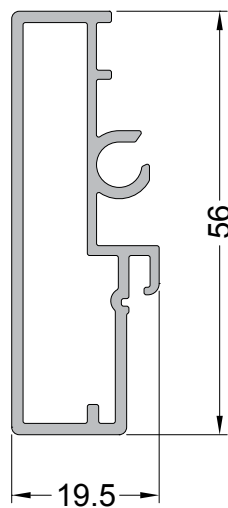

RB-202  
0.691 Kg/m

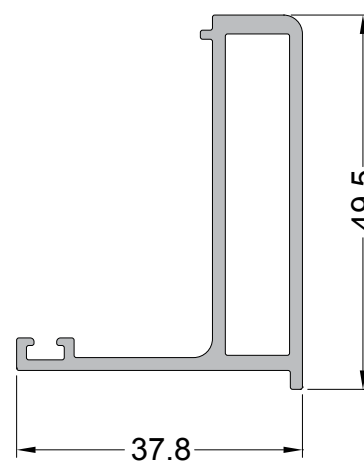

RB-79701

0.378 Kg/m

Complemento

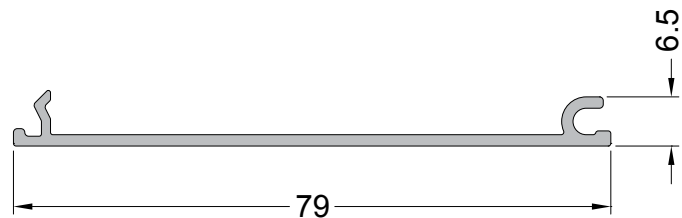

RB-79801

0.628 Kg/m

Complemento

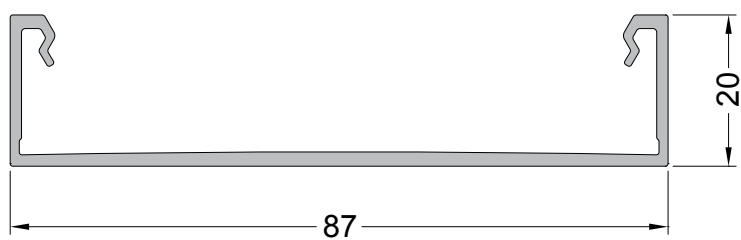

RB-501

0.203 Kg/m

Complemento

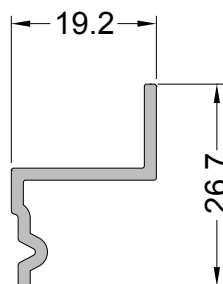

RB-103  
1.564 Kg/m  
Luva

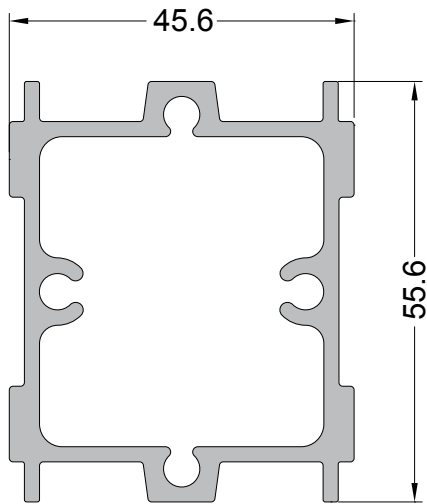

RB-104  
2.113 Kg/m  
Luva

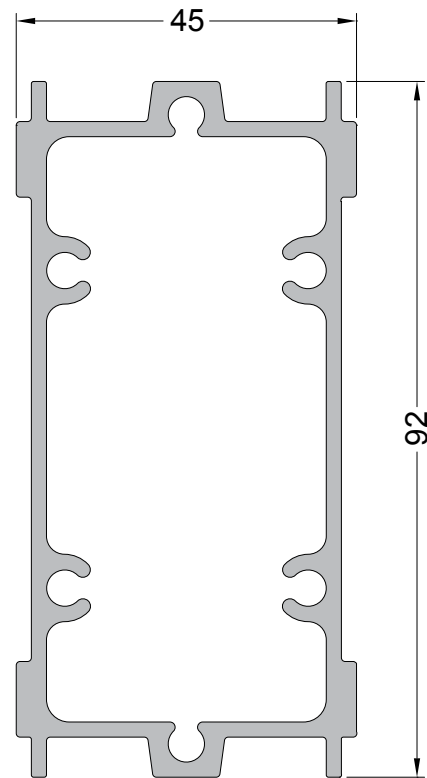

RB-83701  
1.760 Kg/m  
Ancoragem

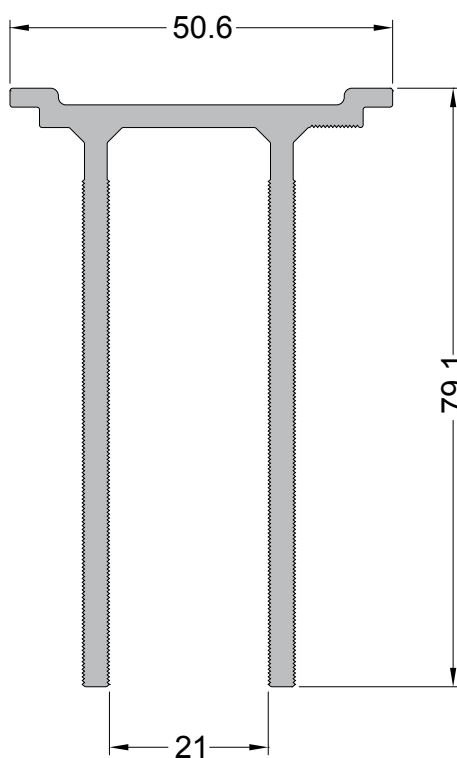



LC-204

0.798 Kg/m

Montante  
Entre-Vão

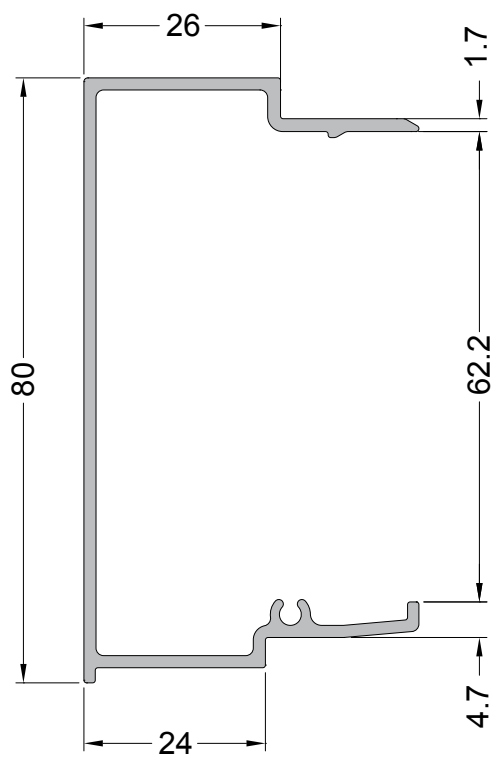

LC-304

0.659 Kg/m

Montante  
Entre-Vão

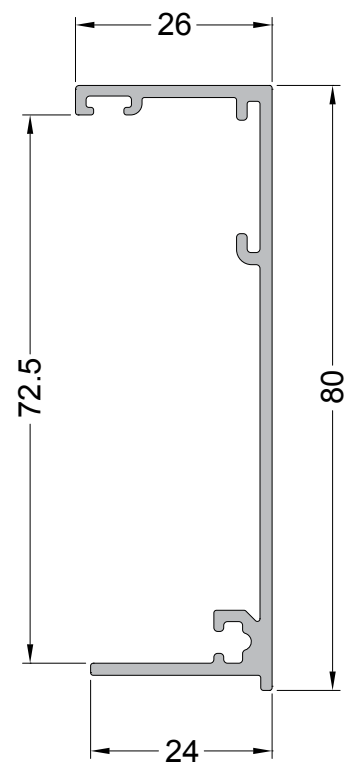

LC-76505  
1,570 kg/m  
Montante

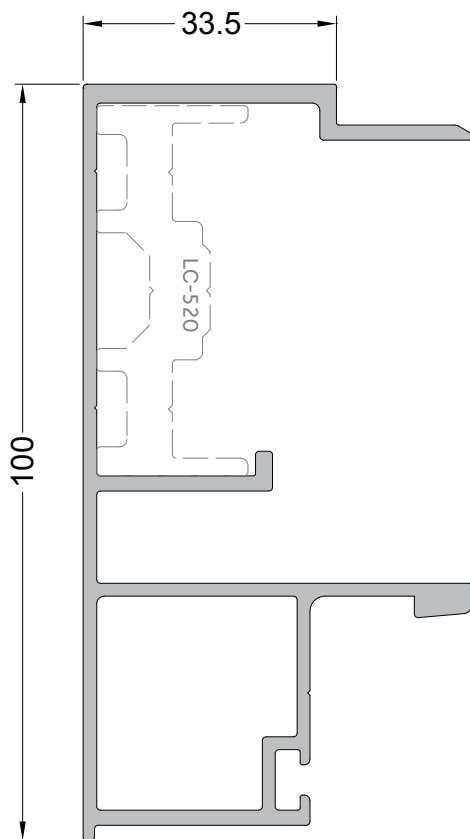

LC-76515  
1,309 kg/m  
Montante

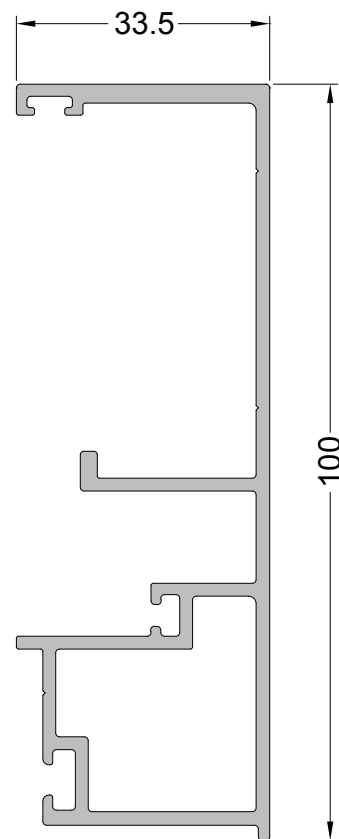

LC-76506 (LC-006)

1,735 kg/m

Montante

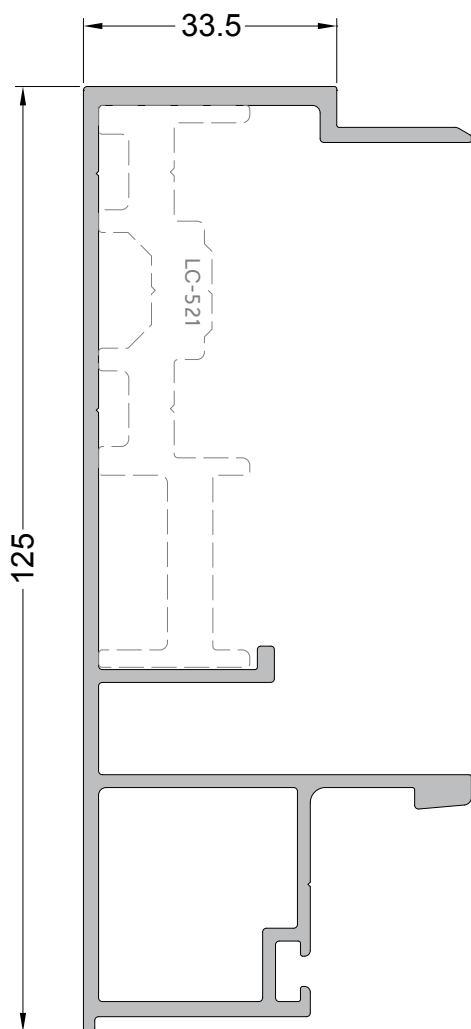

LC-76516 (LC-106)

1,486 kg/m

Montante

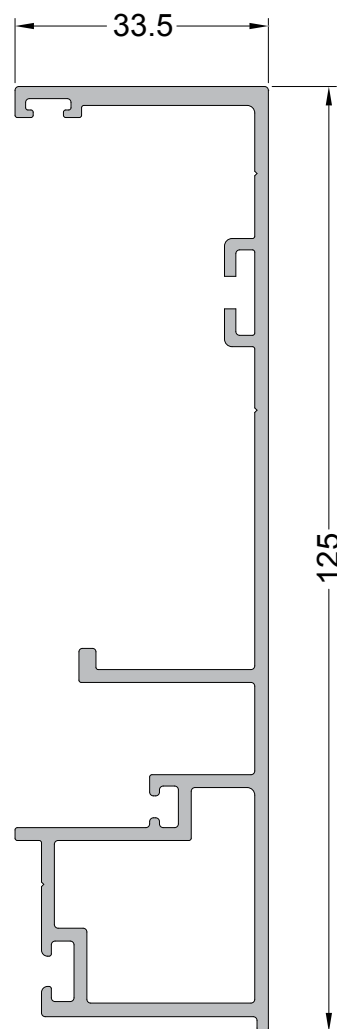

LC-76502  
1,525 kg/m  
Montante

LC-76501  
1,609 kg/m  
Montante

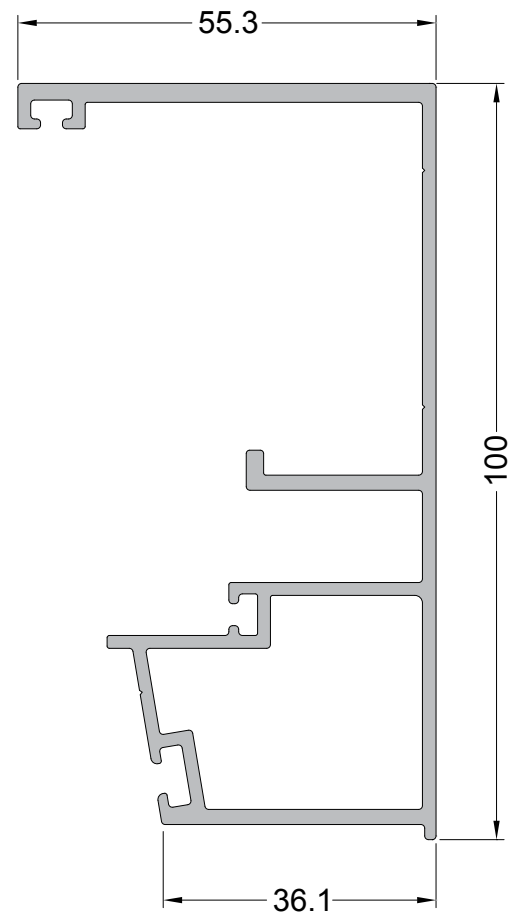
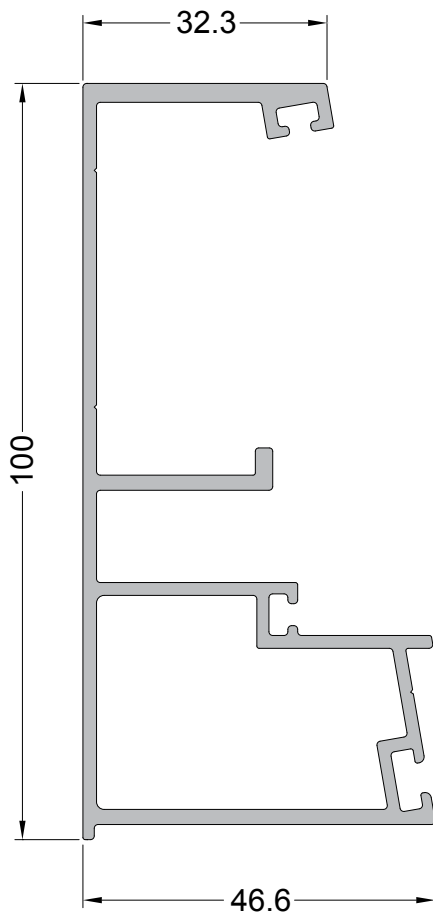

LC-26001  
1.495 Kg/m  
Montante

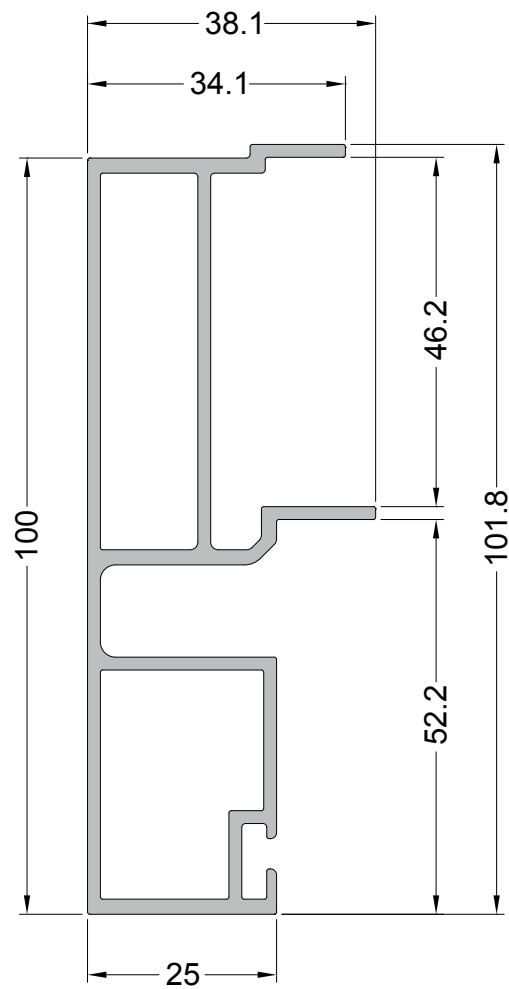

LC-015  
2,186 kg/m  
Montante Canto 90°

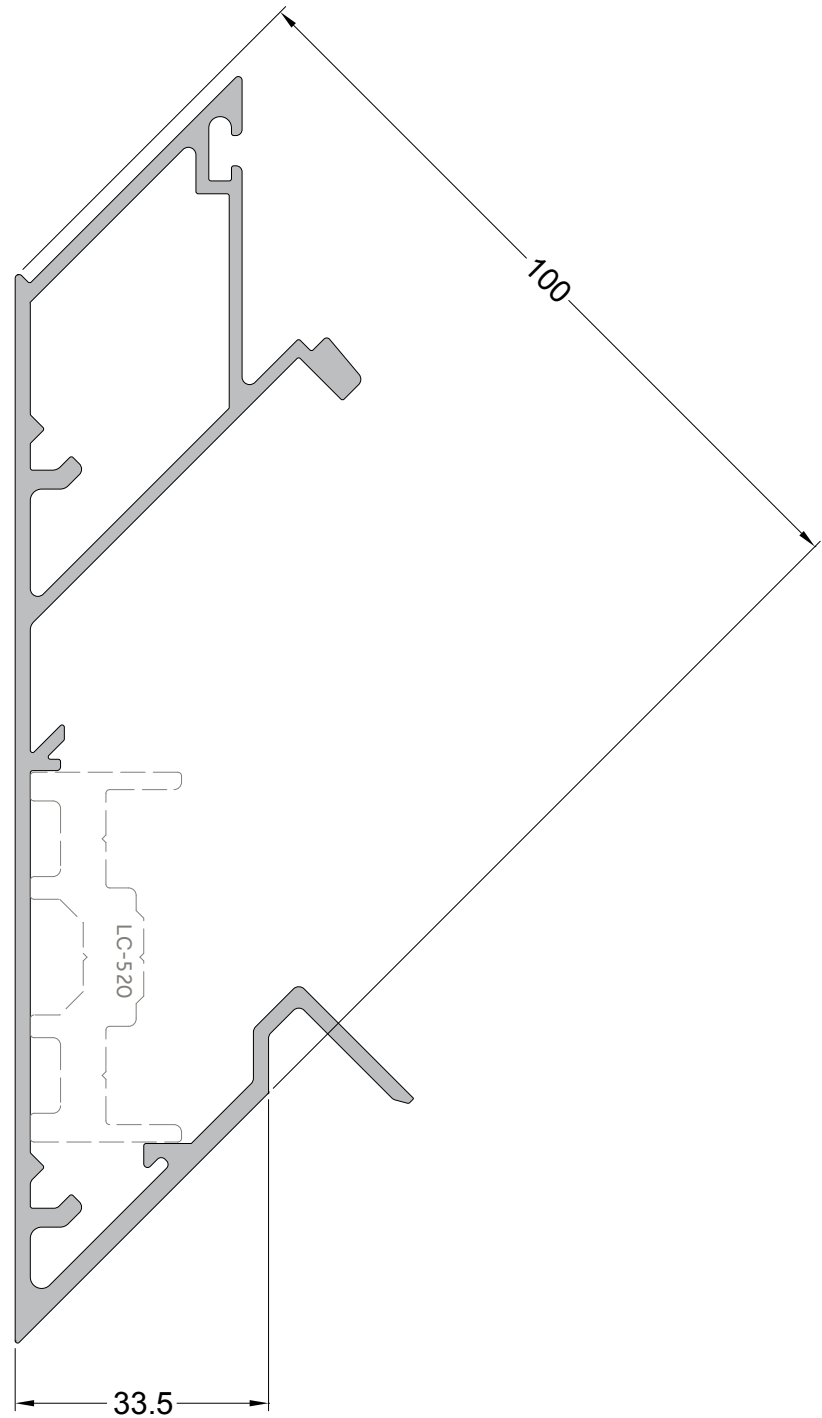

PERFIS, PROJETOS, CÓDIGOS E SISTEMAS ESTÃO SUJEITOS A ALTERAÇÃO SEM AVISO PRÉVIO.

LC-115  
1,931 kg/m  
Montante Canto 90°

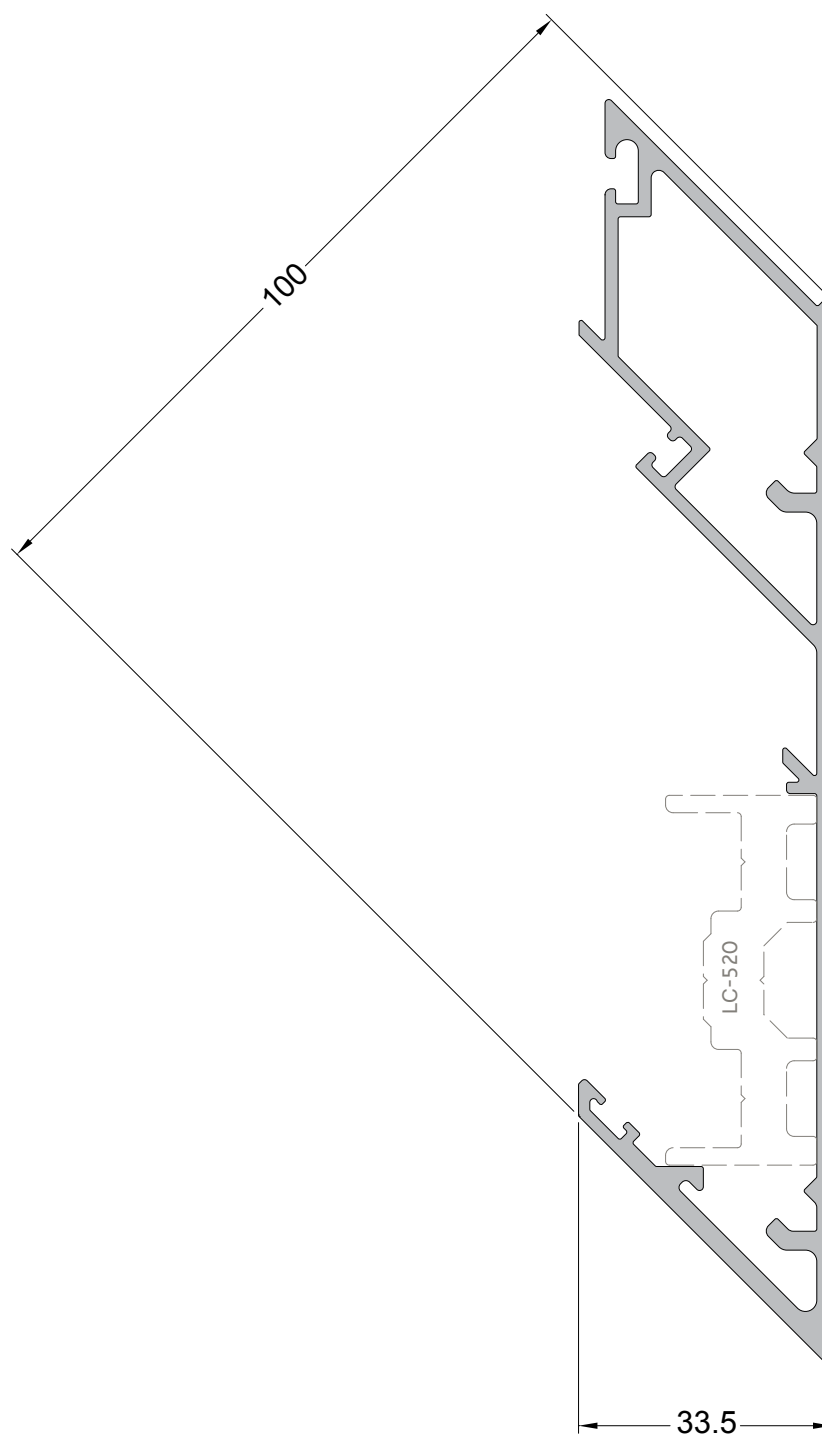

LC-016  
2,437 kg/m  
Montante Canto 90°

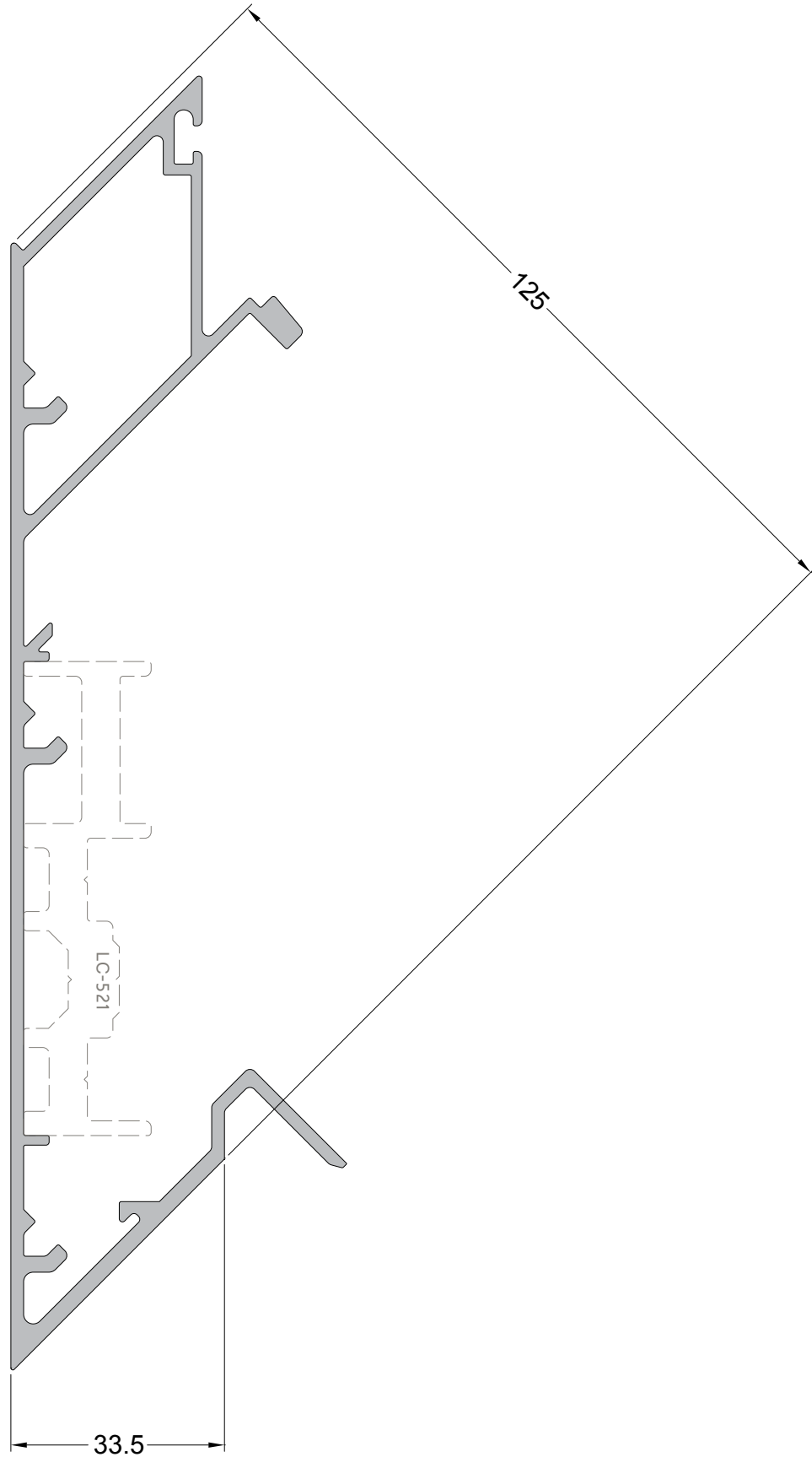



LC-116  
2,185 kg/m  
Montante Canto 90°

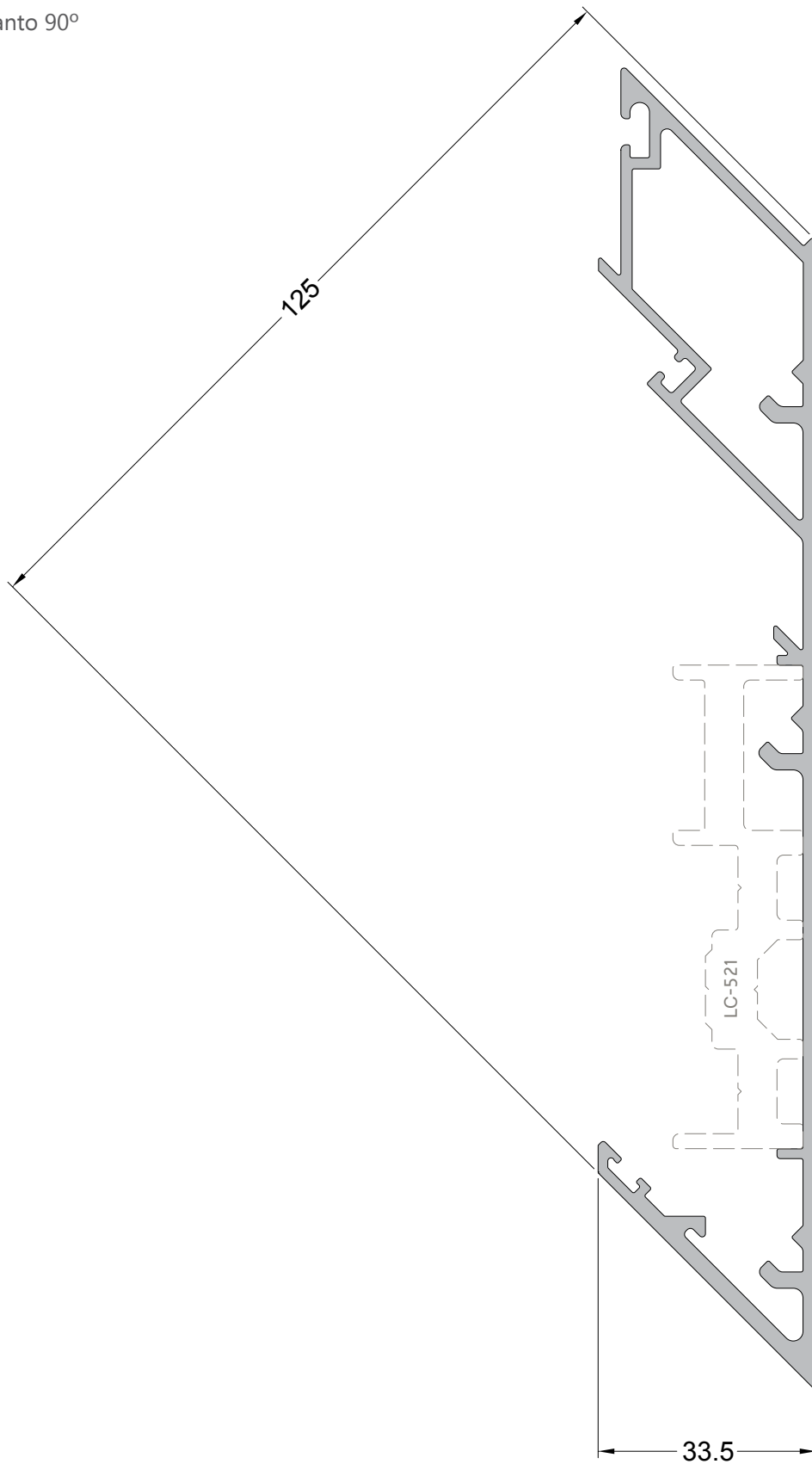

LC-017  
2,215 kg/m  
Montante Canto 90°

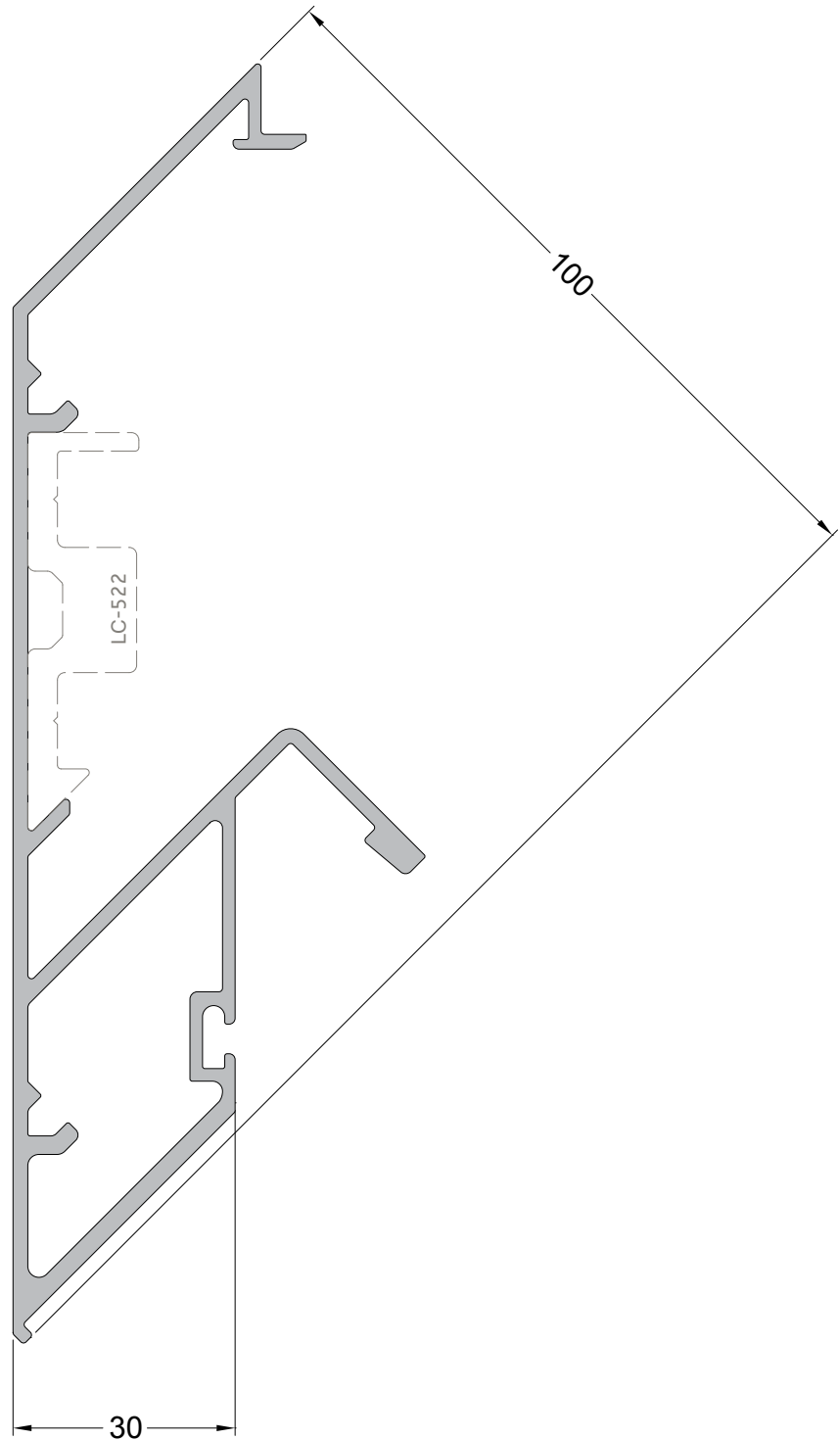

LC-117

2,033 kg/m

Montante Canto 90°

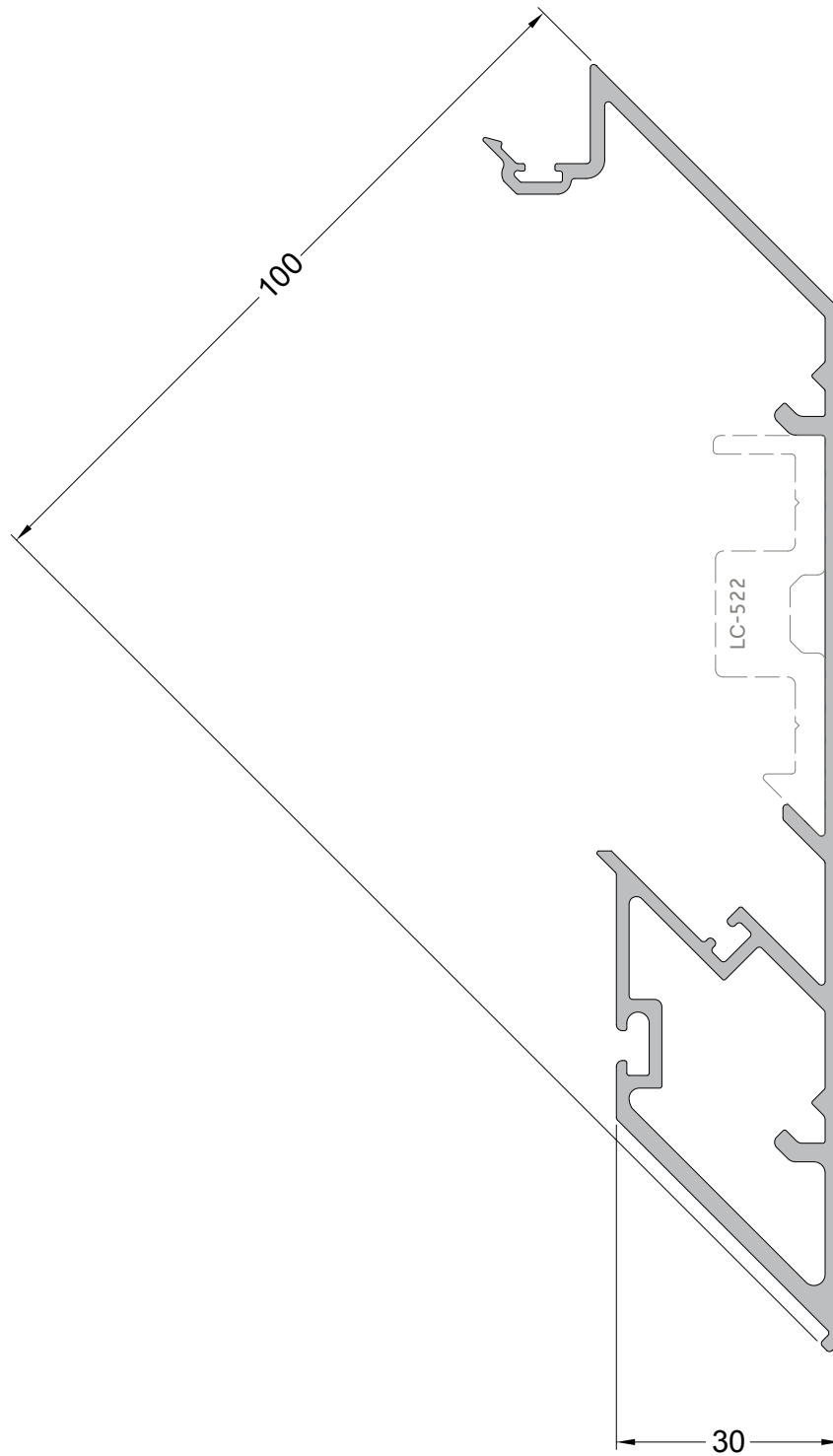

LC-018  
2,497 kg/m  
Montante Canto90°

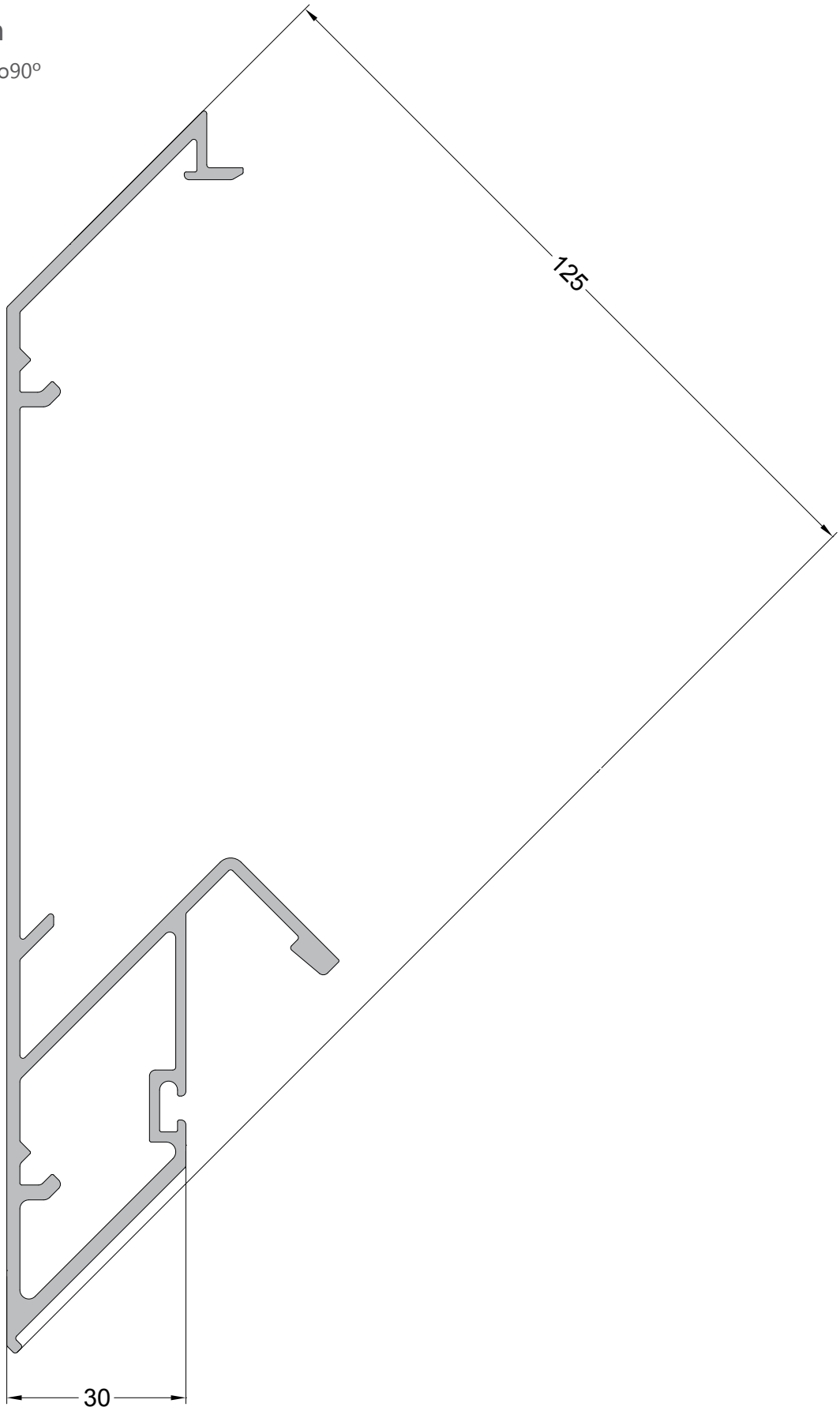

LC-118

2,303 kg/m

Montante Canto 90°

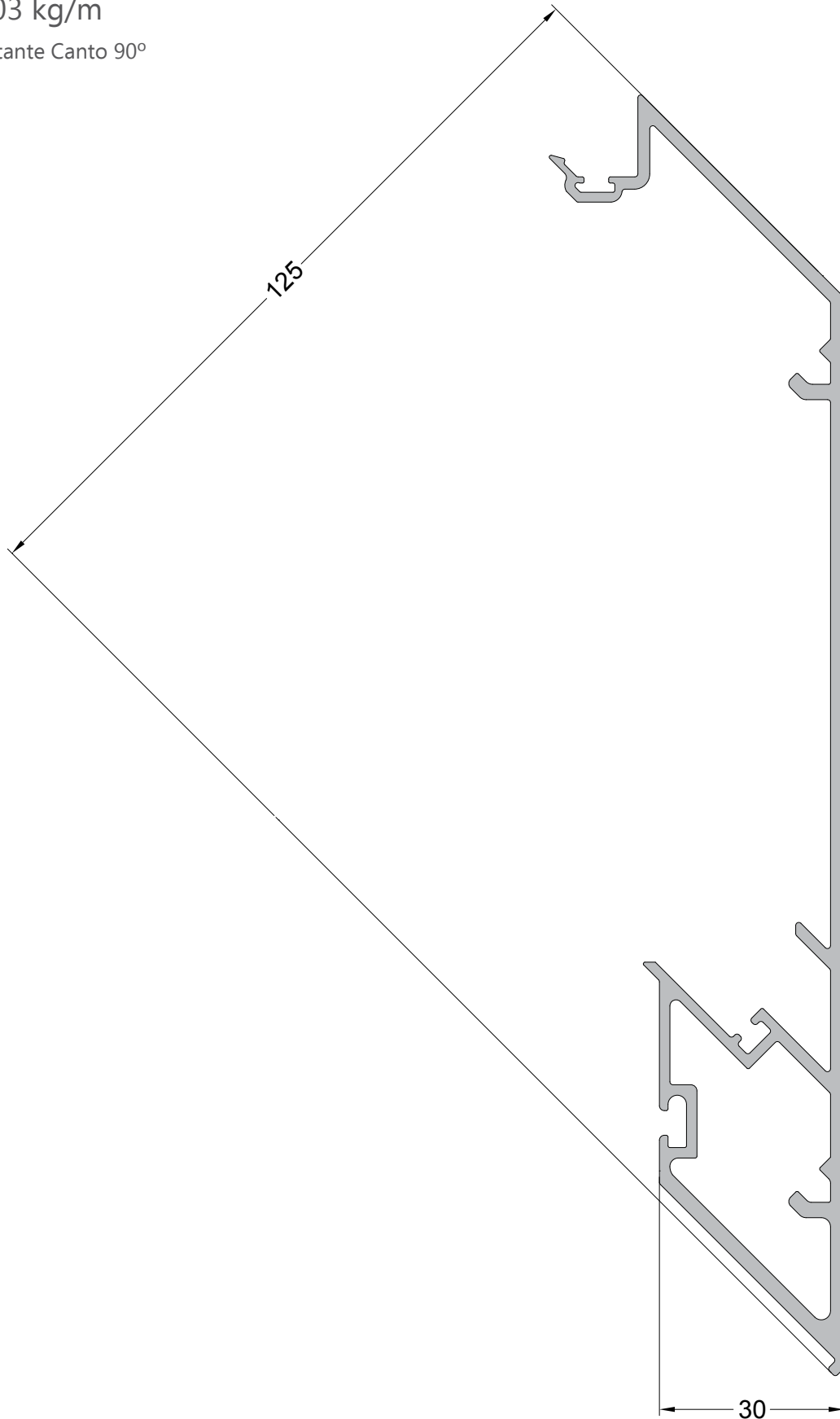

LC-76503  
1,948 kg/m  
Montante Canto

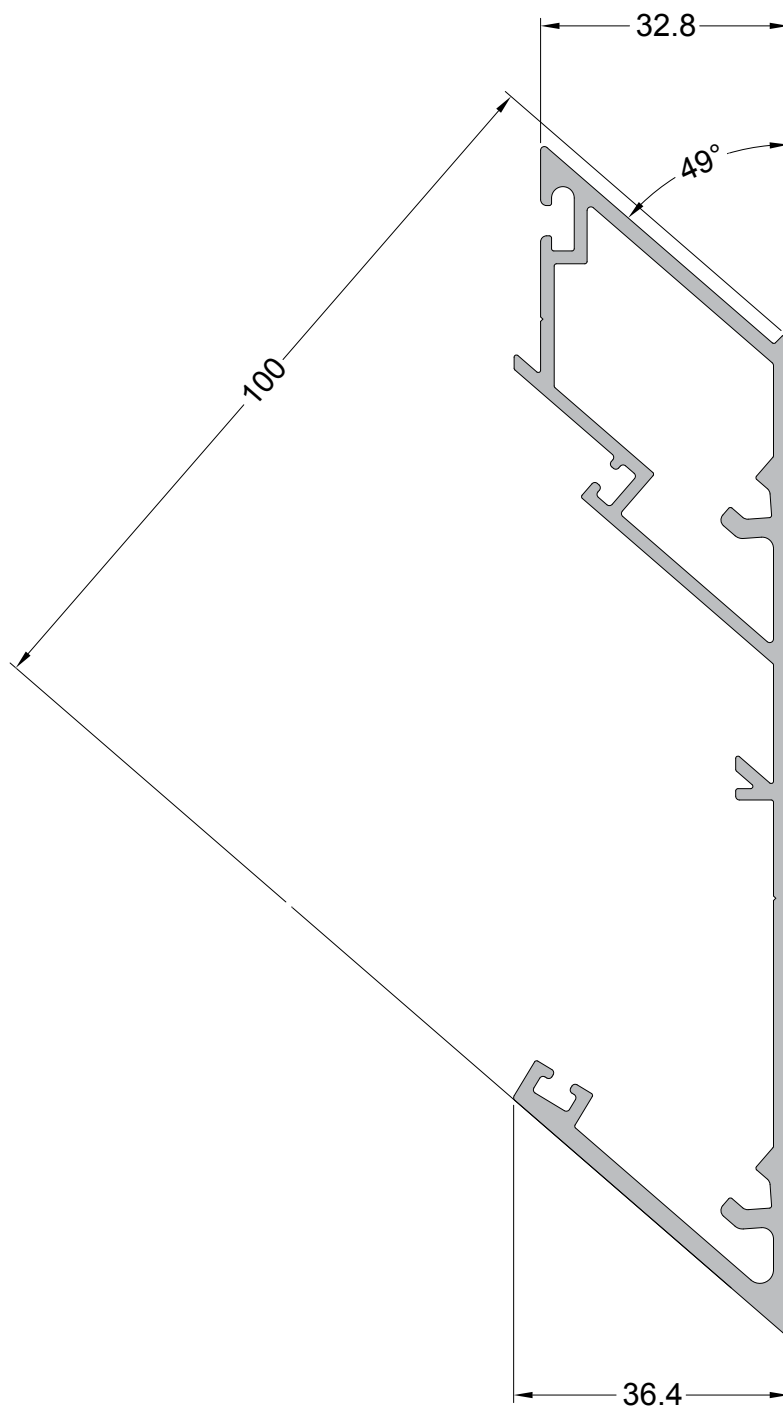

LC-76504  
2,333 kg/m  
Montante Canto

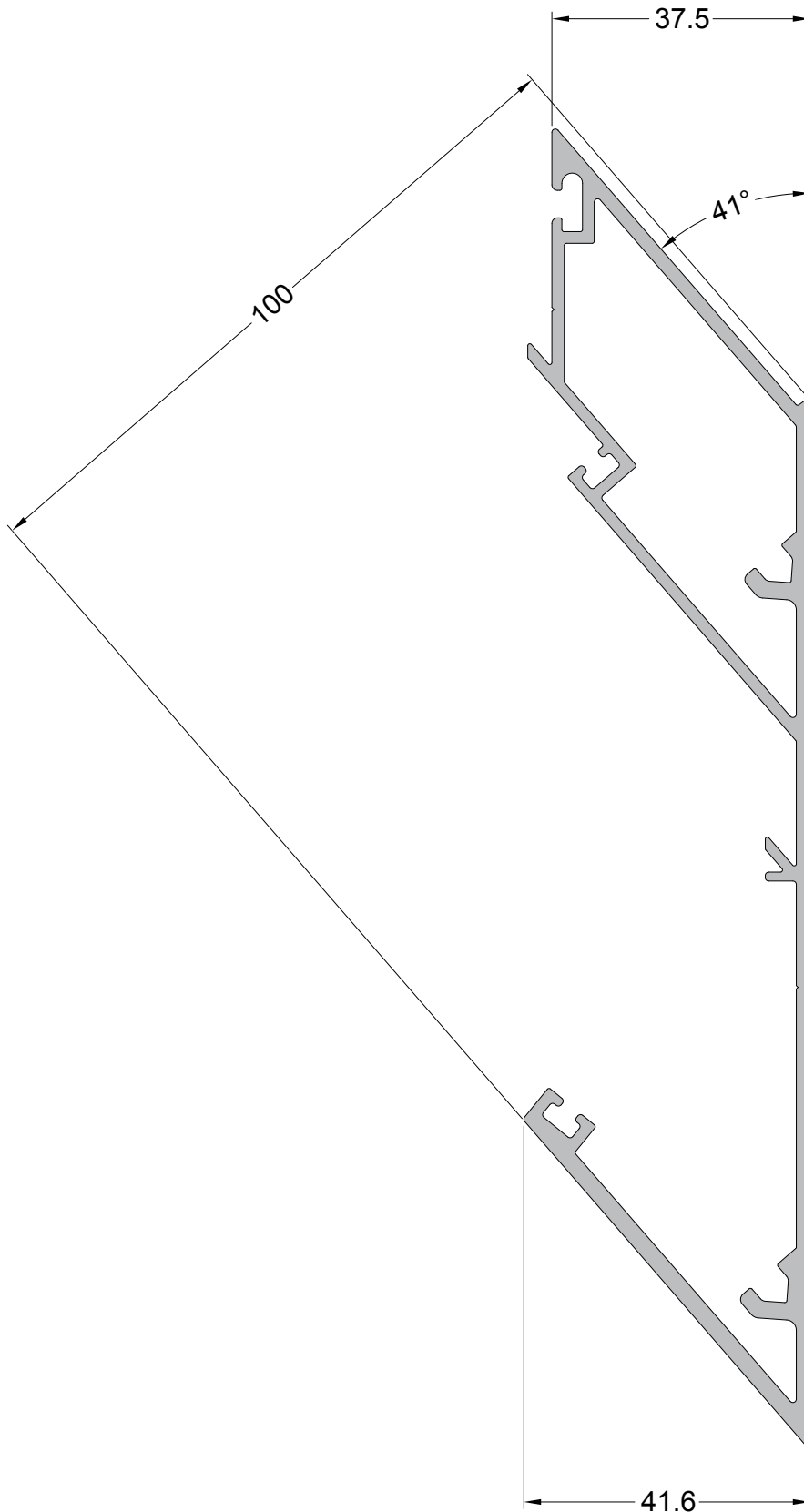

LC-214  
1,172 Kg/m  
Coluna Canto

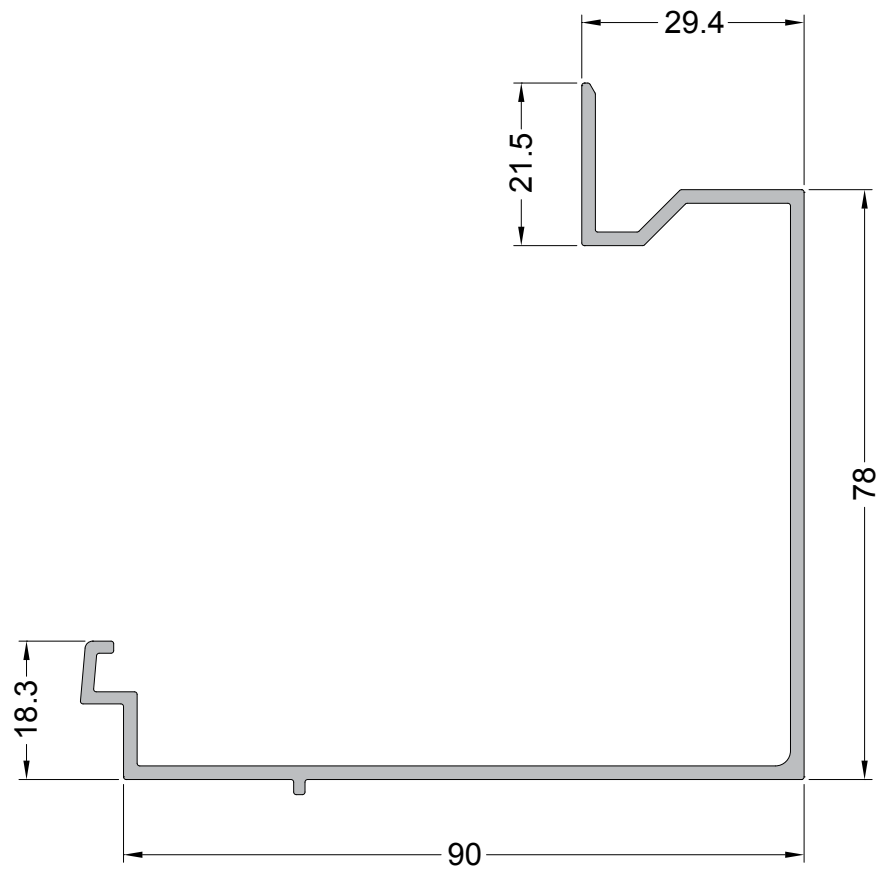

LC-314  
0.983 Kg/m  
Coluna Canto

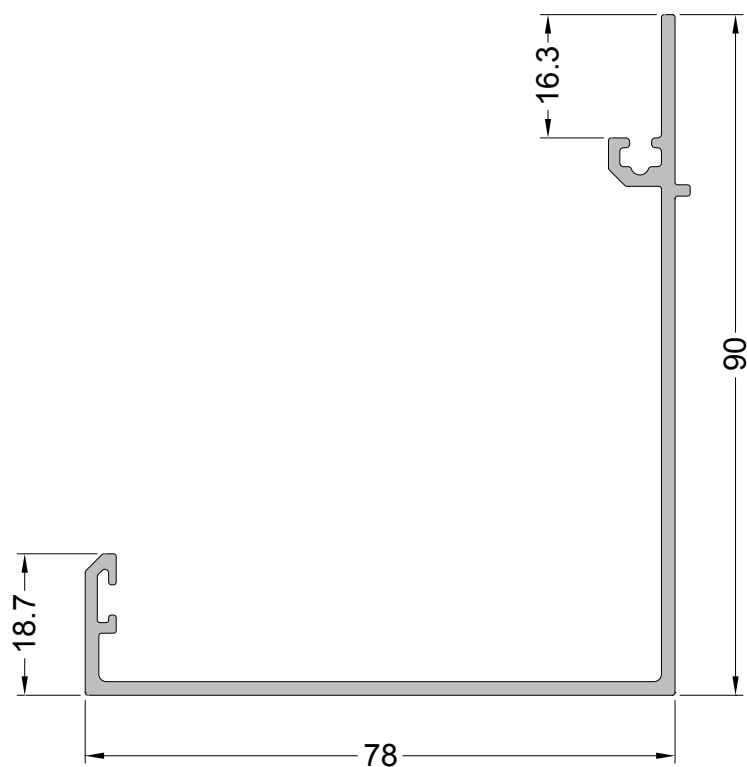



LC-334

0,967 Kg/m

Travessa Superior

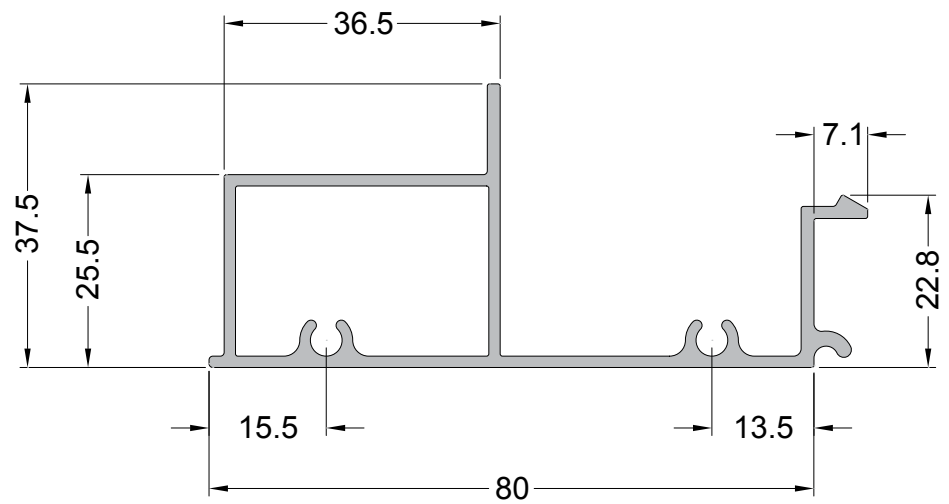

LC-335

1.085 Kg/m

Travessa Superior

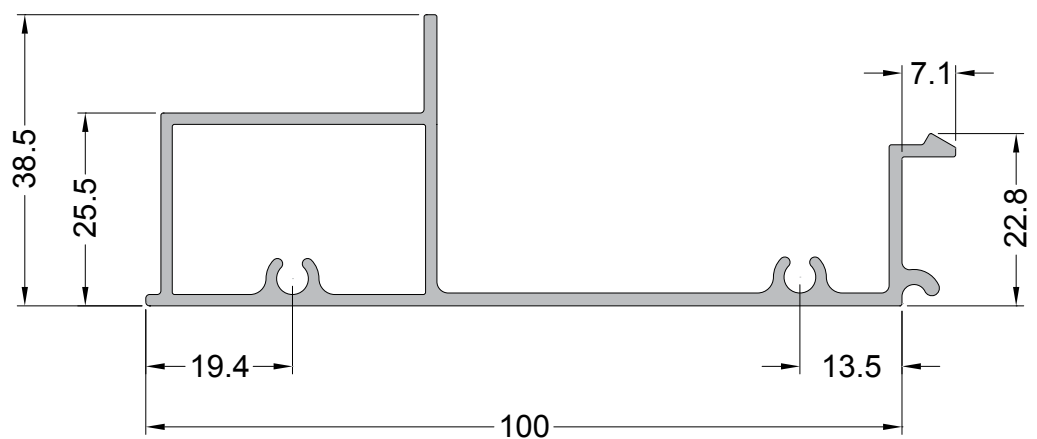

LC-26103  
1.035 Kg/m  
Travessa

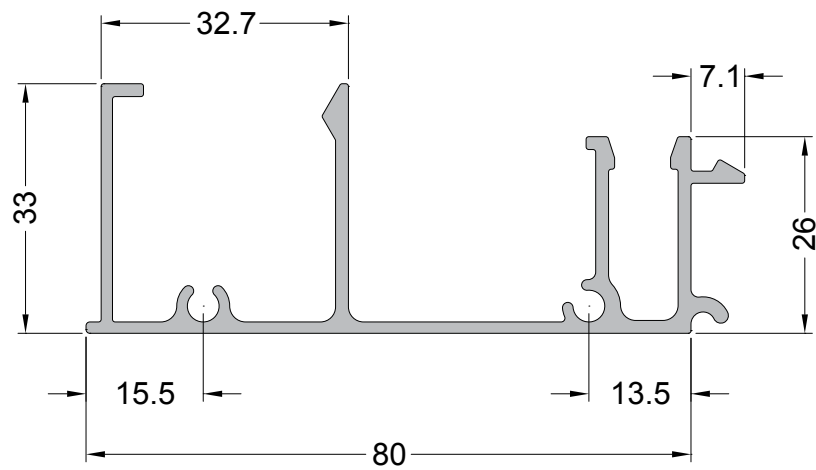

LC-26102  
1.116 Kg/m  
Travessa

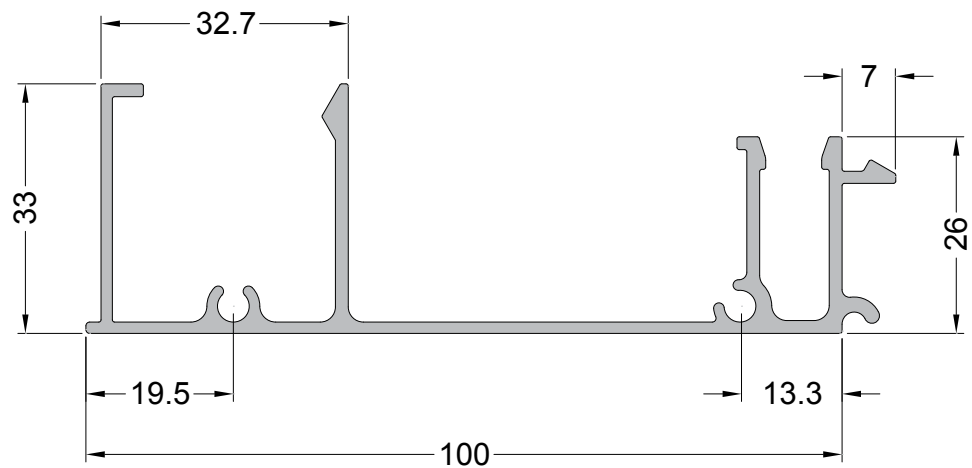

LC-364

0,696 Kg/m

Marco Superior

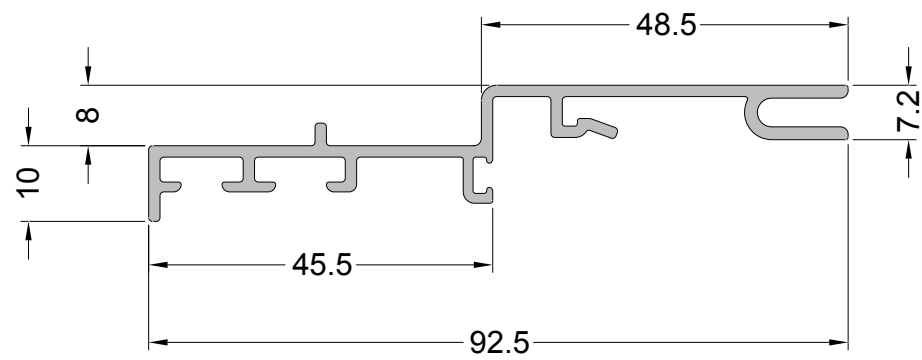

LC-365

0,784 Kg/m

Marco Superior

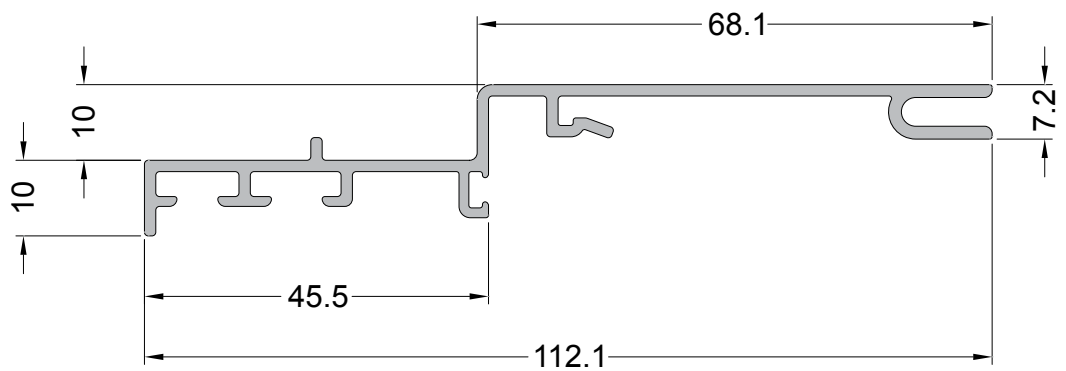

LC-234  
0,953 Kg/m  
Travessa Inferior

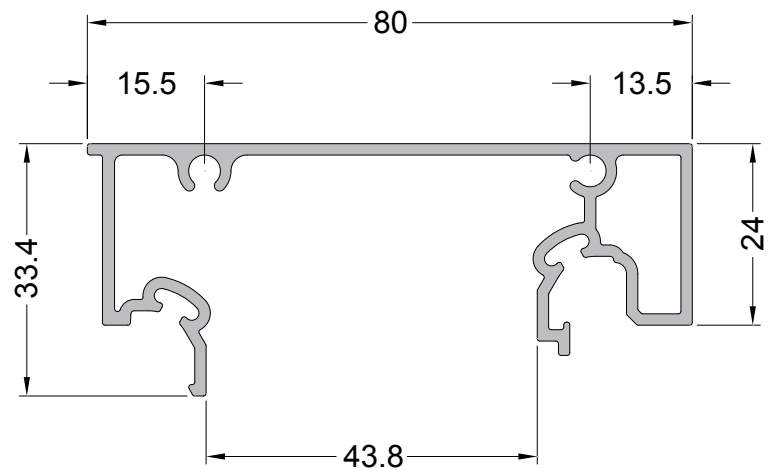

LC-235  
1,034 Kg/m  
Travessa Inferior

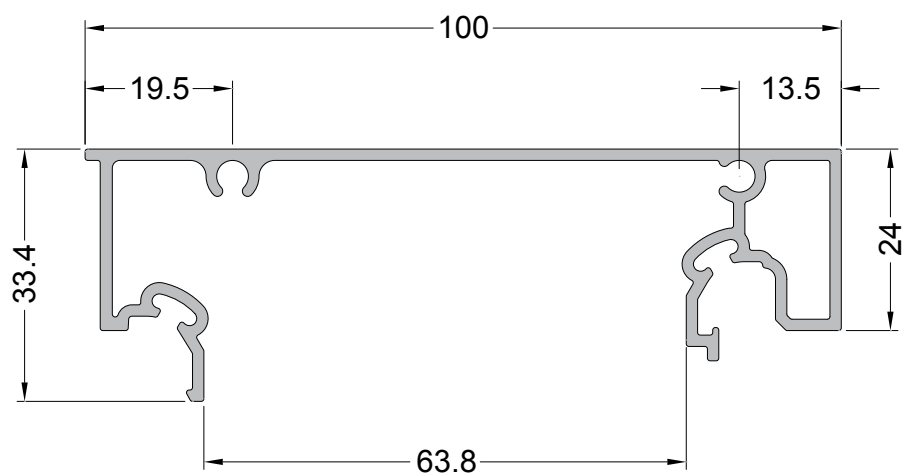

LC-264  
0,998 Kg/m  
Marco Inferior

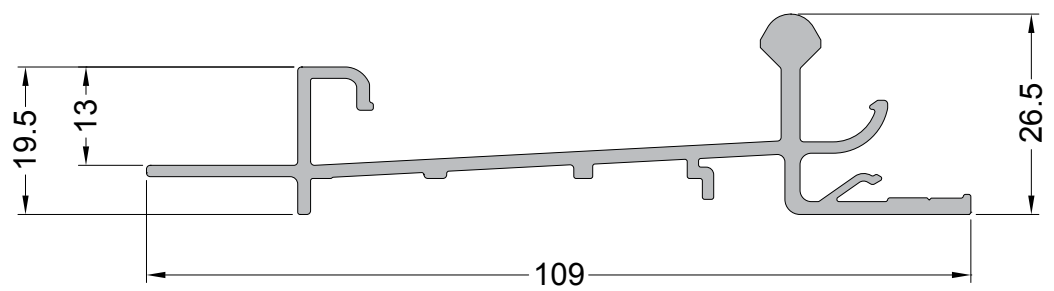

LC-265  
1,116 Kg/m  
Marco Inferior

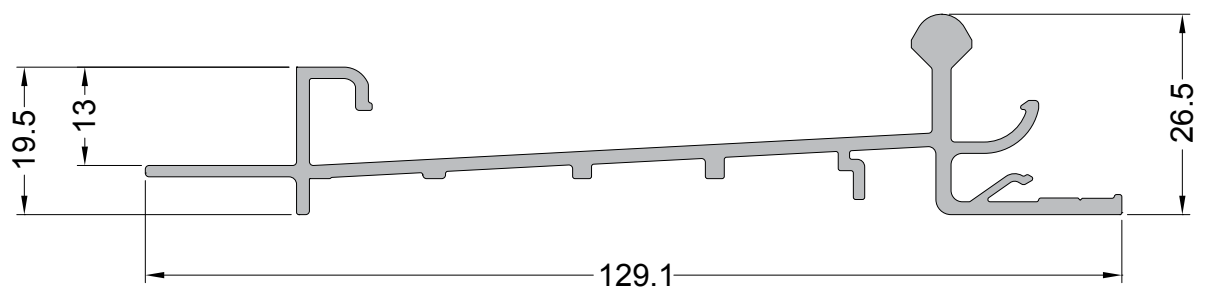

LC-07003

1,691 Kg/m

Marco Inferior  
Entre-Vão

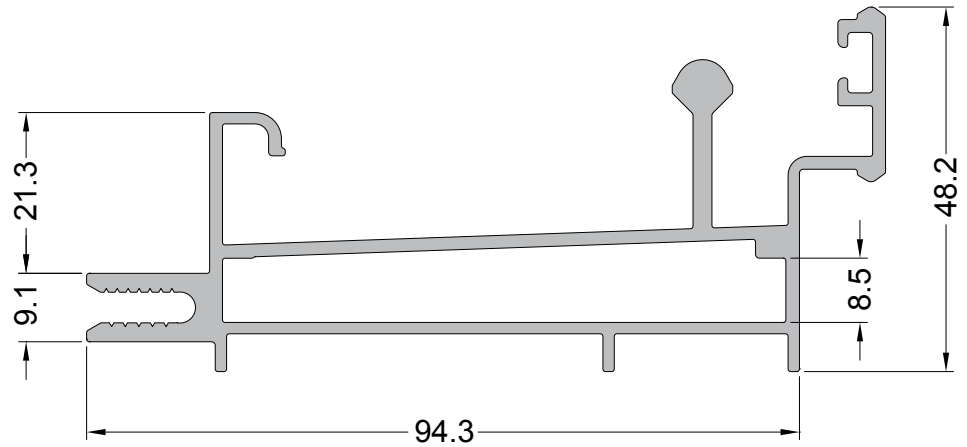

LC-07001

1,027 Kg/m

Marco Inferior

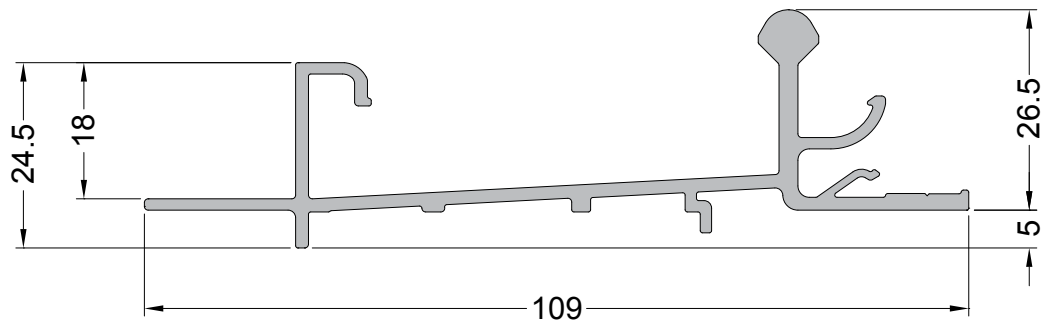

LC-07002

1.145 Kg/m

Marco Inferior

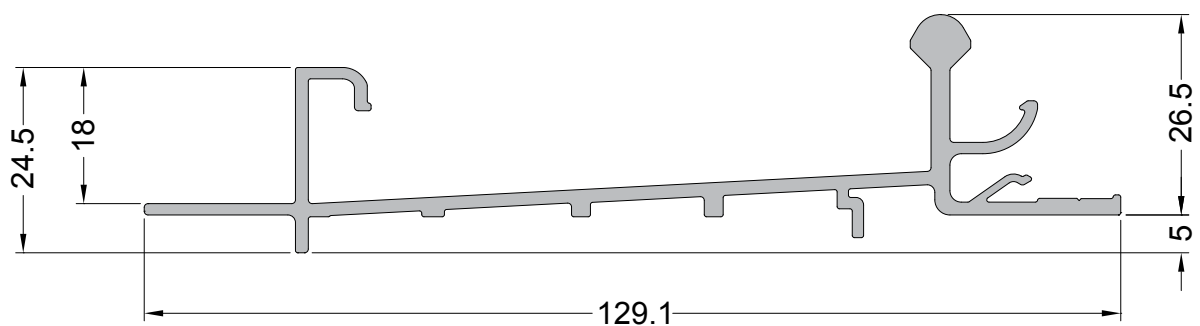

LC-135

1,663 kg/m

Travessa Superior

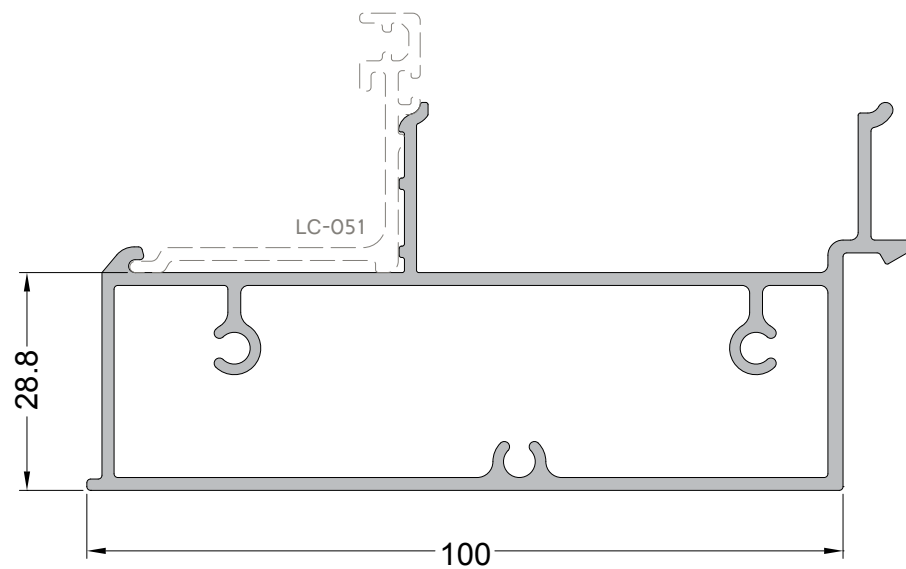

LC-139

1,769 kg/m

Tarvessa Superior

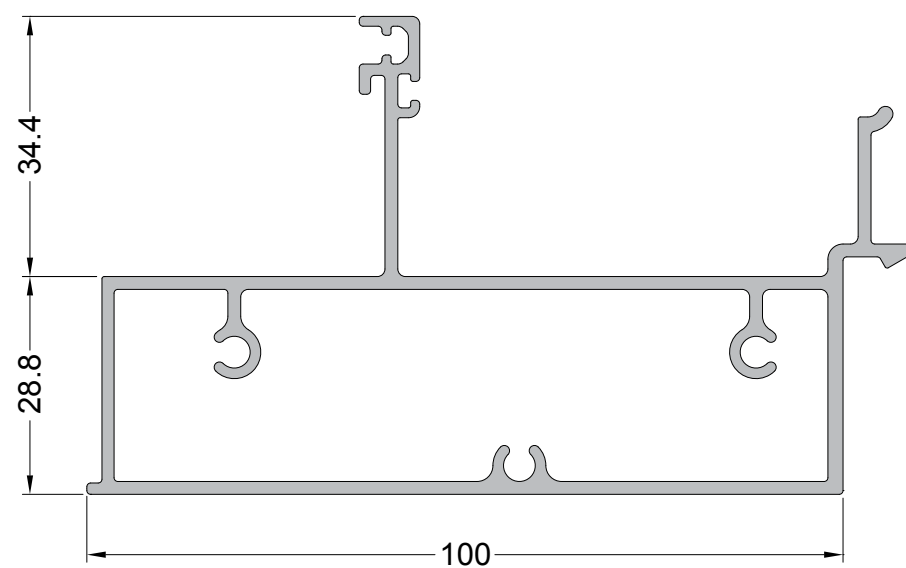

LC-027

1.607 Kg/m

Travessa Intermediária

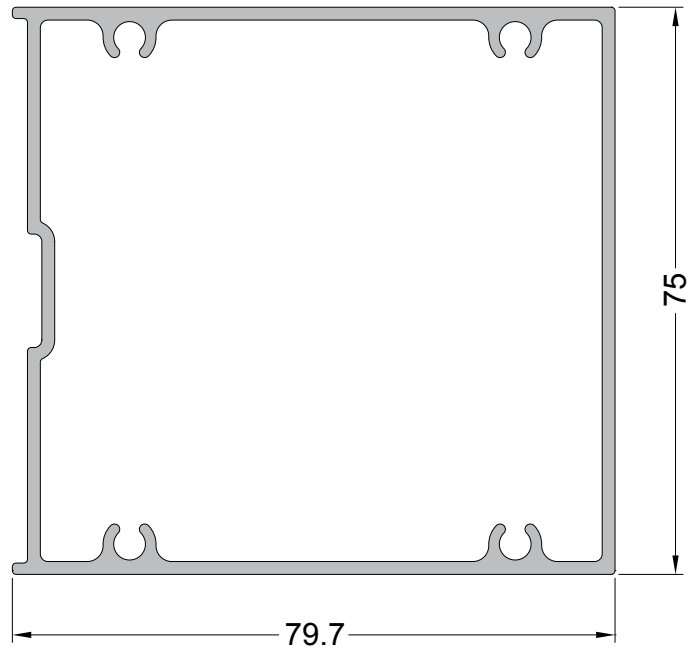

LC-025

1,968 kg/m

Travessa Intermediária

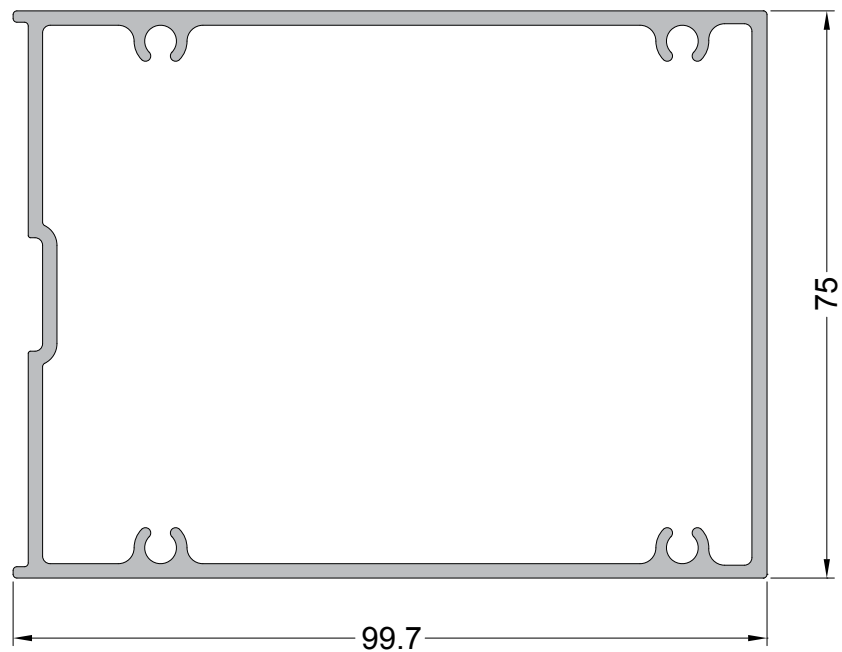



LC-035

1,349 kg/m

Travessa Inferior

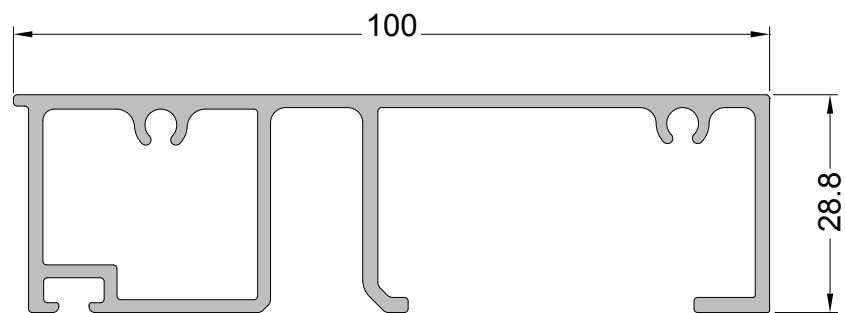

LC-26101

1.007 Kg/m

Marco Travessa

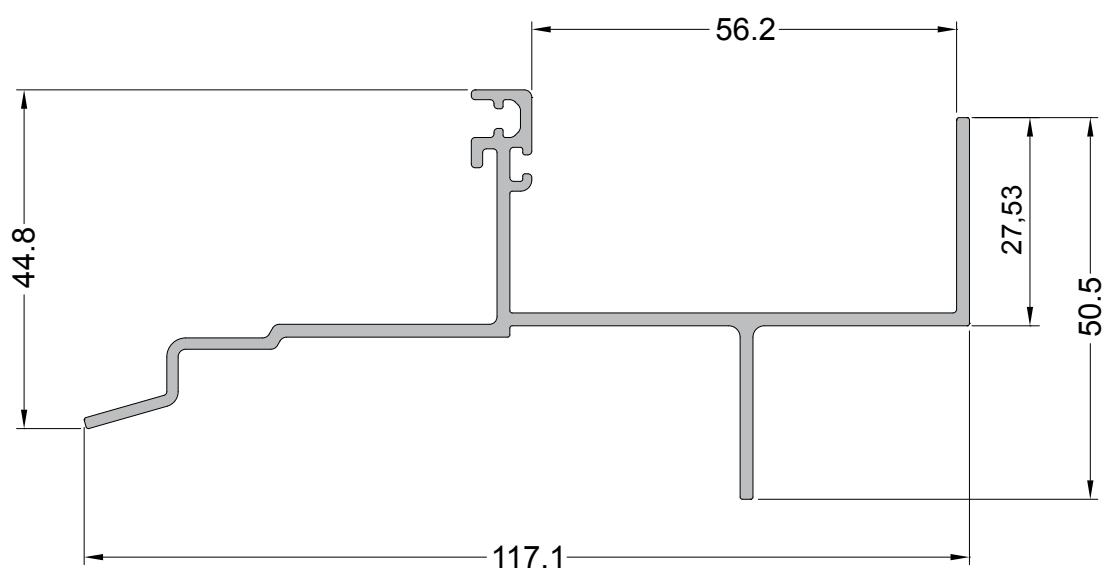

LC-136  
1,897 kg/m  
Travessa Superior

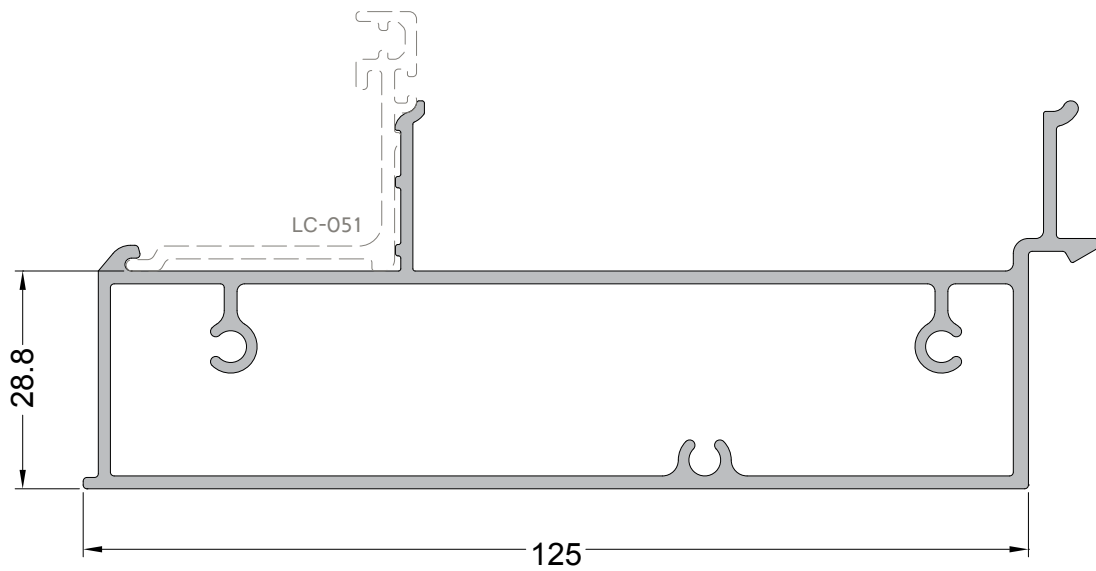

LC-026  
2,226 kg/m  
Travessa Intermediaria

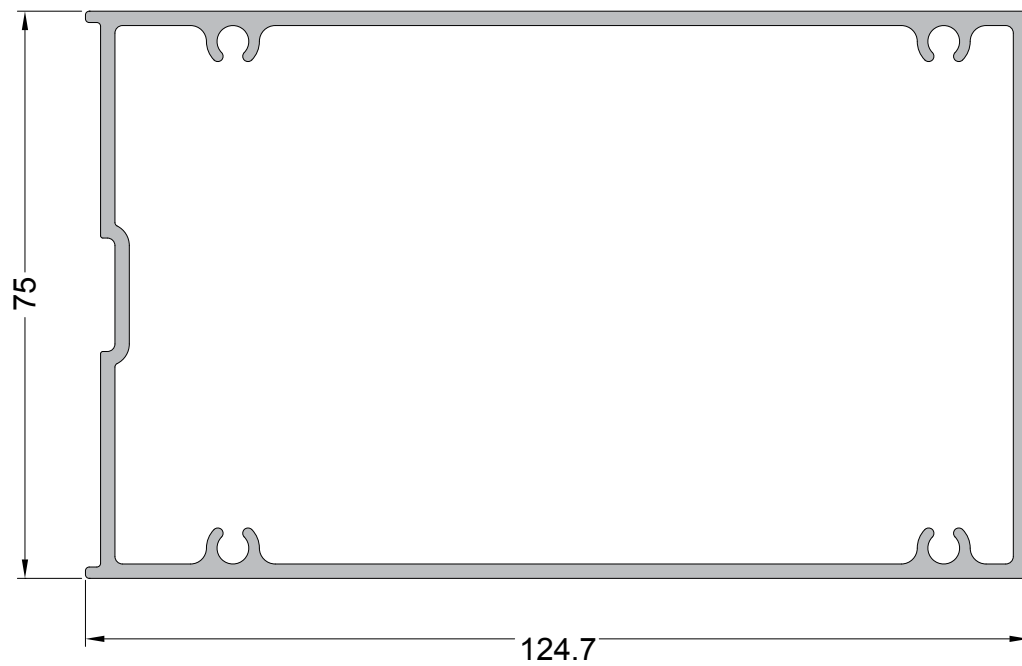

LC-036

1,463 kg/m

Travessa Inferior

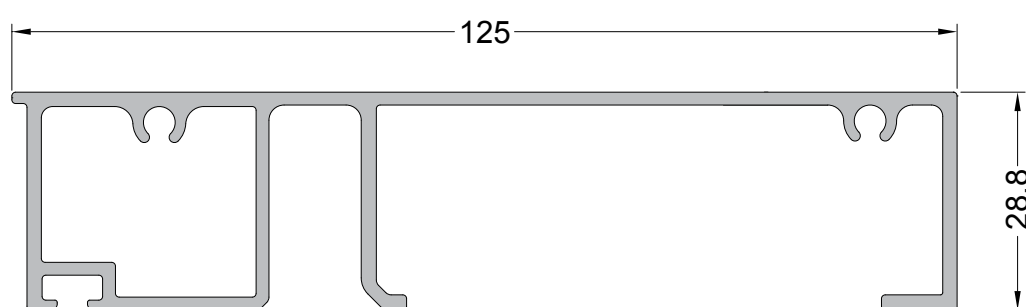

LC-037

1,594 kg/m

Travessa Inferior

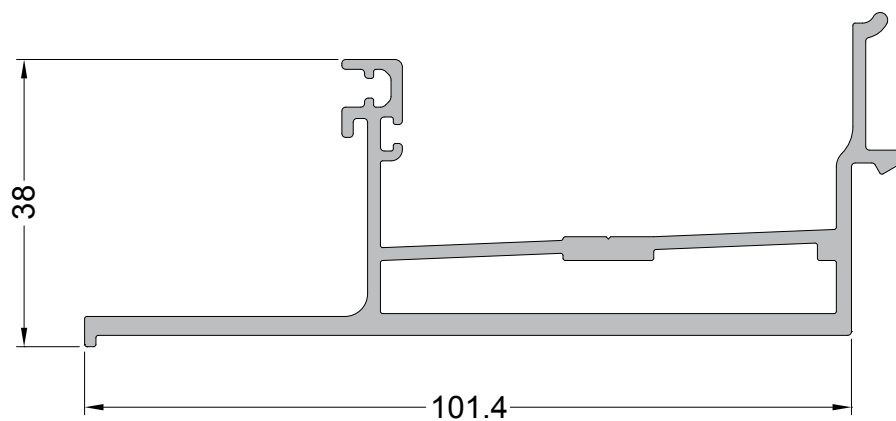

LC-038

1,924 kg/m

Travessa Inferior

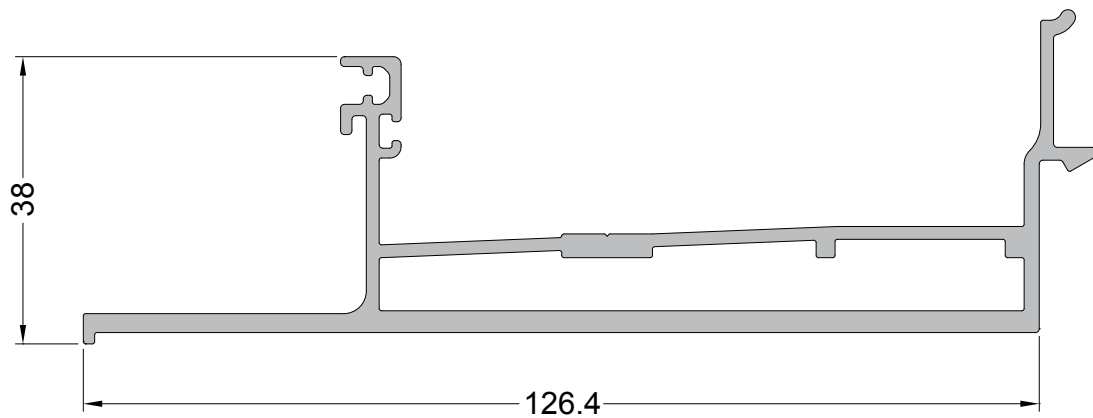

LC-080

1,707 kg/m

Travessa Inferior

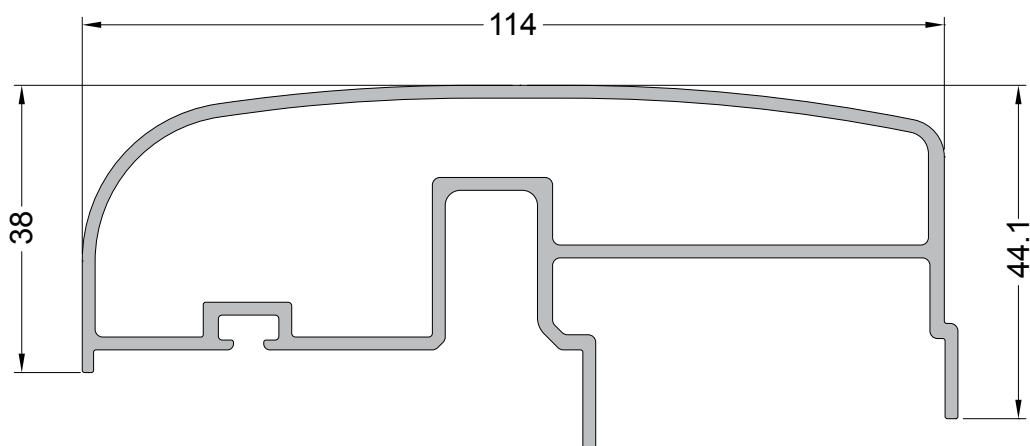

LC-79801

0,297 kg/m

Complemento Travessa

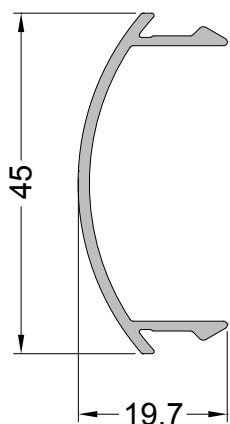

LC-80801

1,092 kg/m

Complemento Travessa

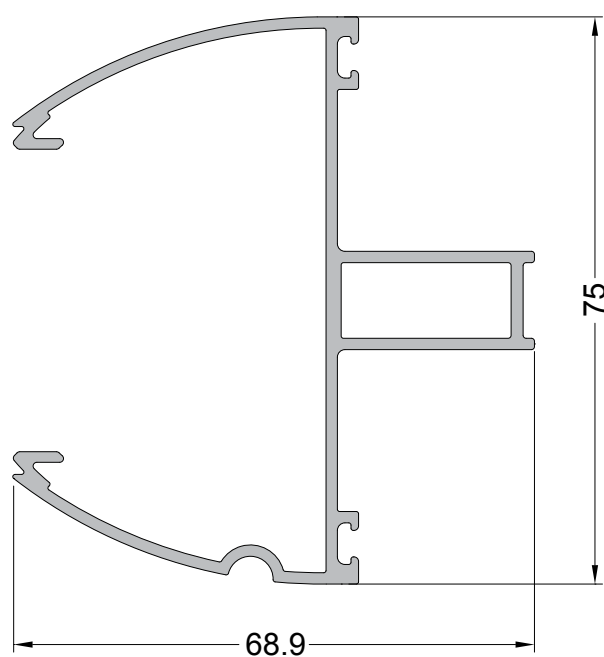

LC-051

0,406 kg/m

Complemento Travessa

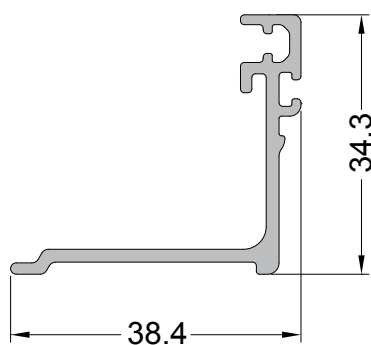

LC-061  
0,326 kg/m  
Arremate

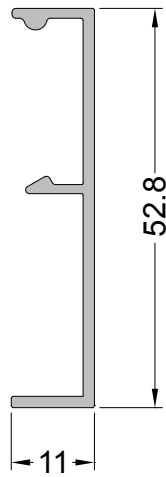

LC-062  
0,413 kg/m  
Arremate

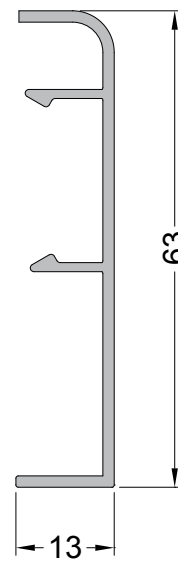

LC-063  
0,237 kg/m  
Arremate

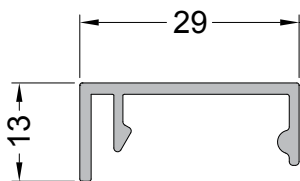

LC-064  
0,215kg/m  
Arremate

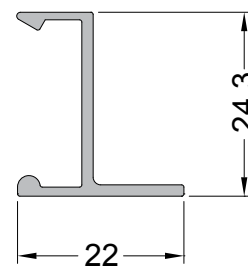

LC-065  
0,150 kg/m  
Arremate

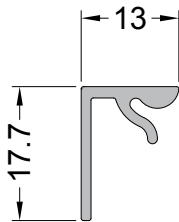

LC-066  
0,482 kg/m  
Arremate

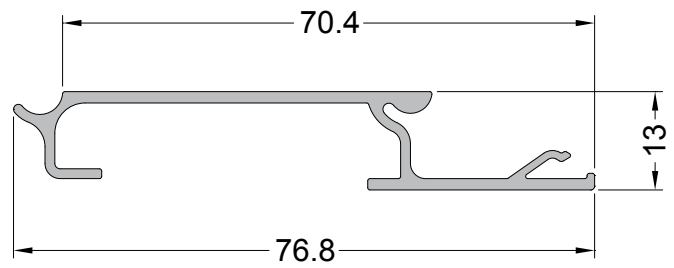

LC-068  
0,203 kg/m  
Tampa Arremate

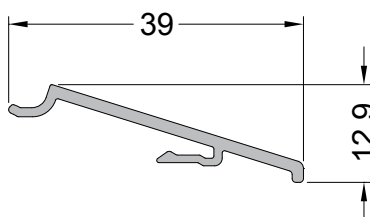

LC-067  
0,539 kg/m  
Arremate

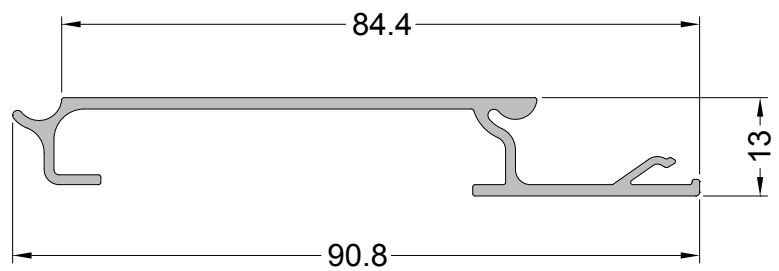

LC-091  
1,580 kg/m  
Tampa

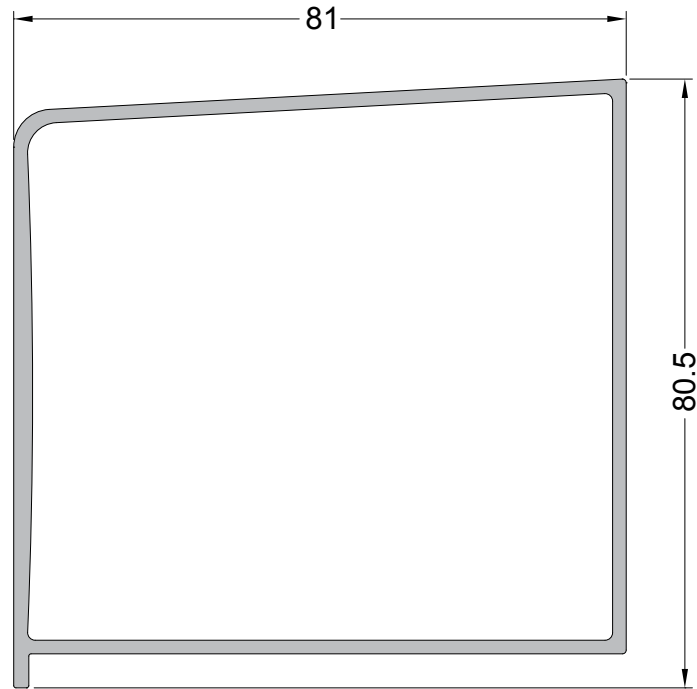

LC-069  
1,370 kg/m  
Arremate

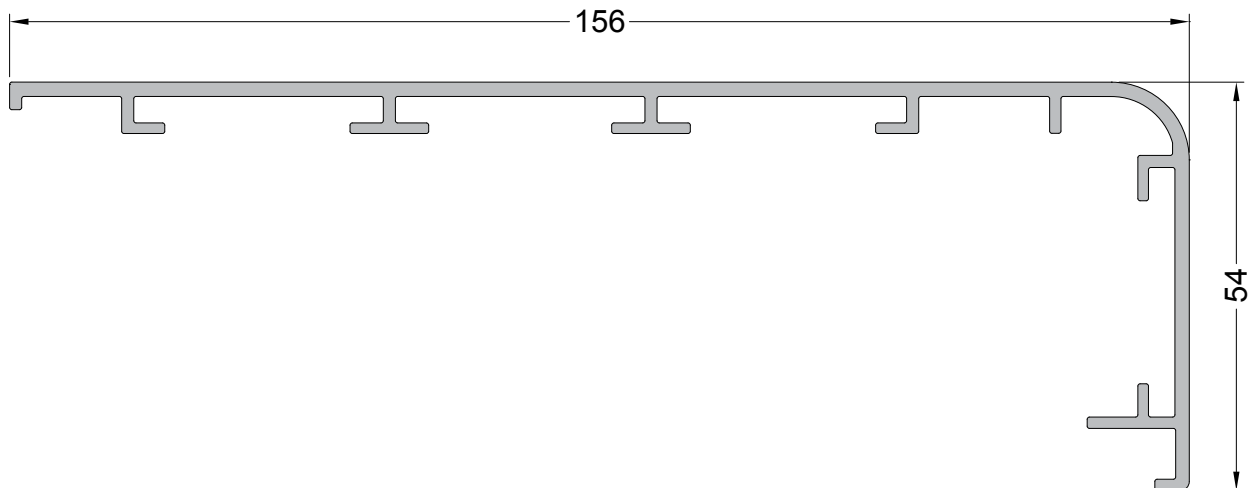



LC-055  
0,515 kg/m  
Tampa Lateral

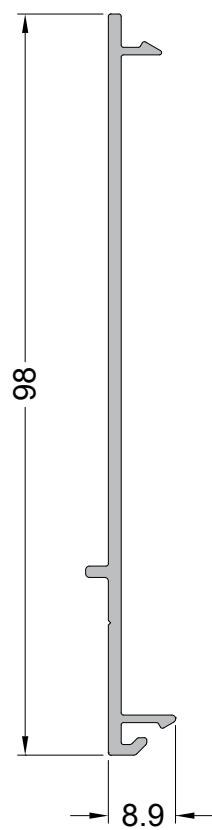

LC-056  
0,618 kg/m  
Tampa Lateral 125

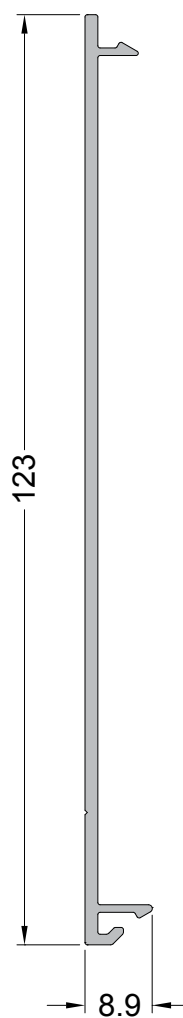

LC-221  
0,889 kg/m  
Marco Maxim-ar

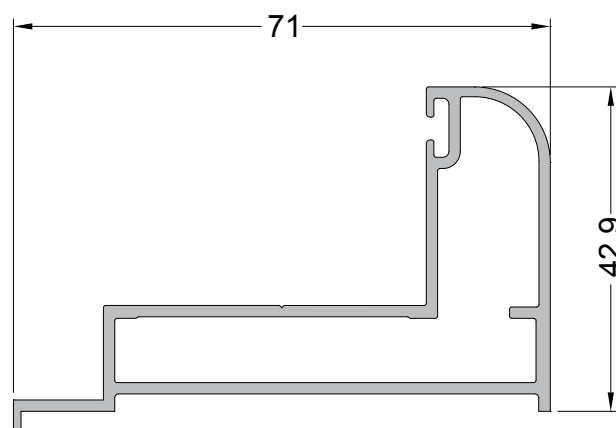

RB-202  
0.691 Kg/m  
Folha

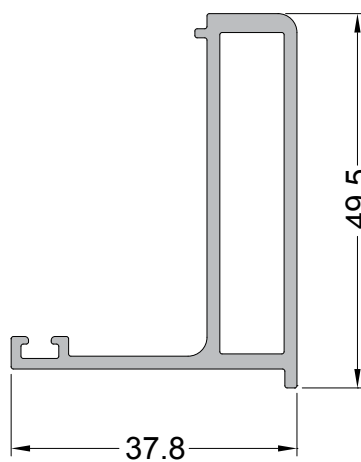

LC-254  
0,491 kg/m  
Tampa Lateral

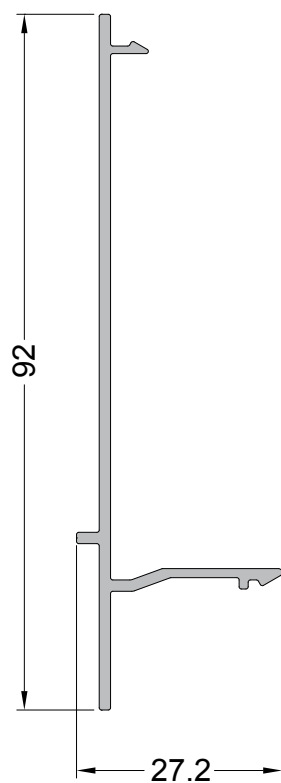

LC-72801  
0,226 kg/m  
Pingadeira

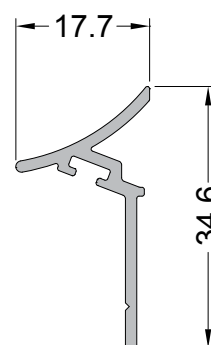

LC-508

4,036 kg/m

Sapata Frente de Pilar

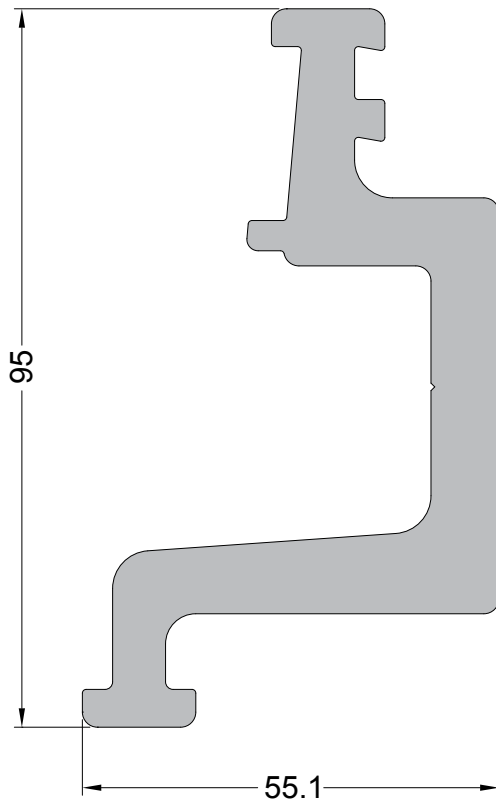

LC-500

6,334 kg/m

Sapata

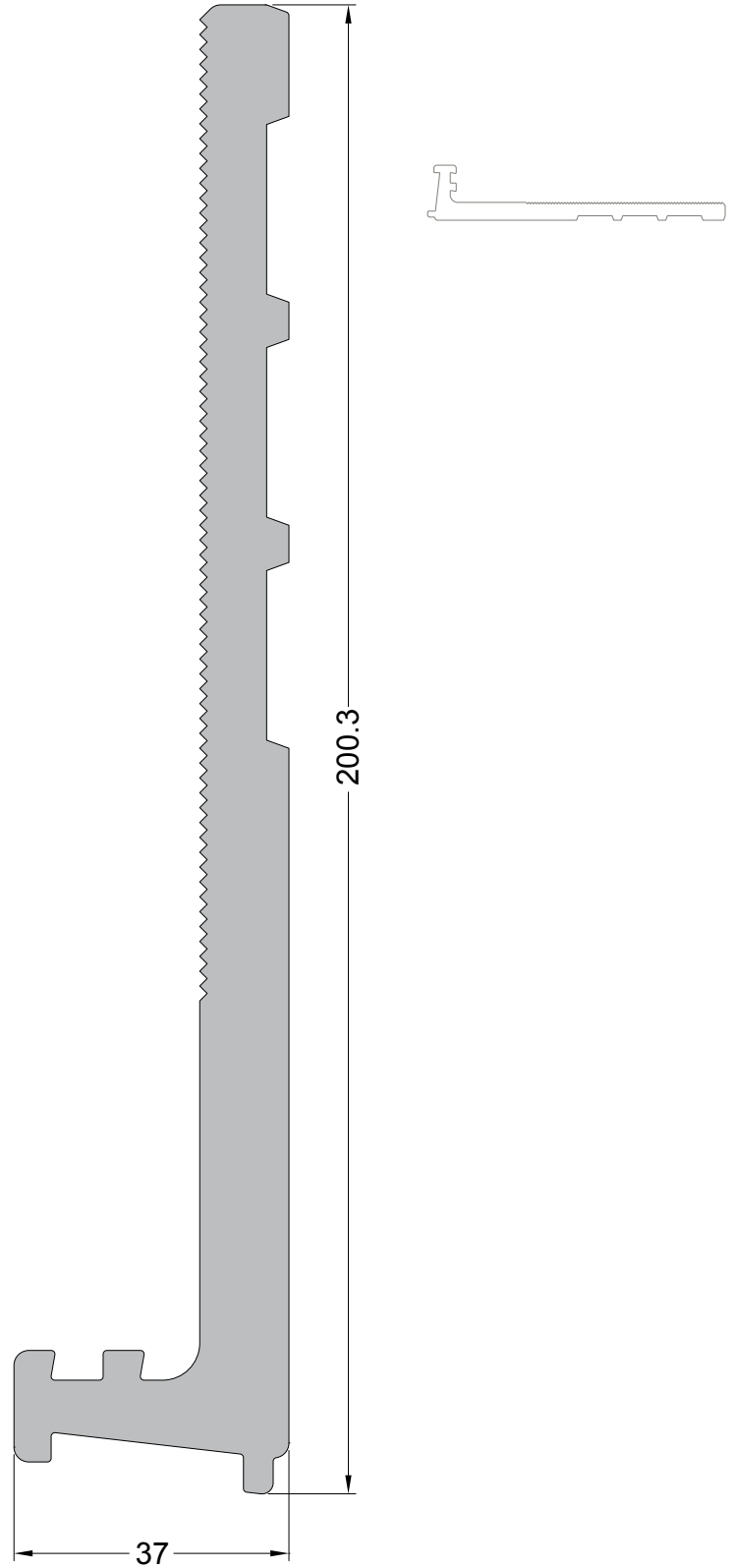

LC-503

2,867 kg/m

Apoio de Regulagem

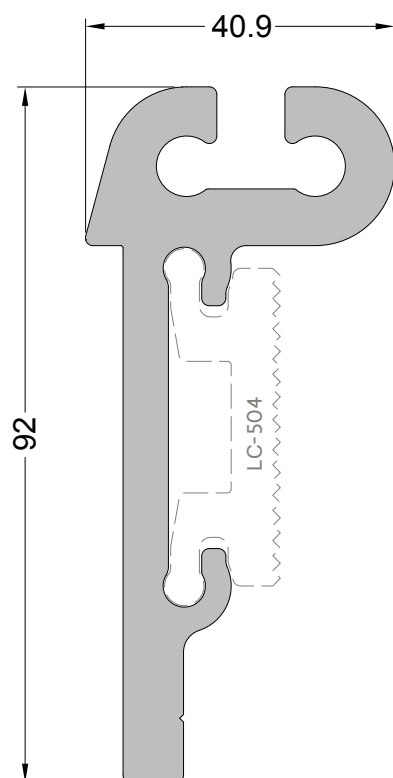

LC-506

2,826 kg/m

Apoio de Regulagem

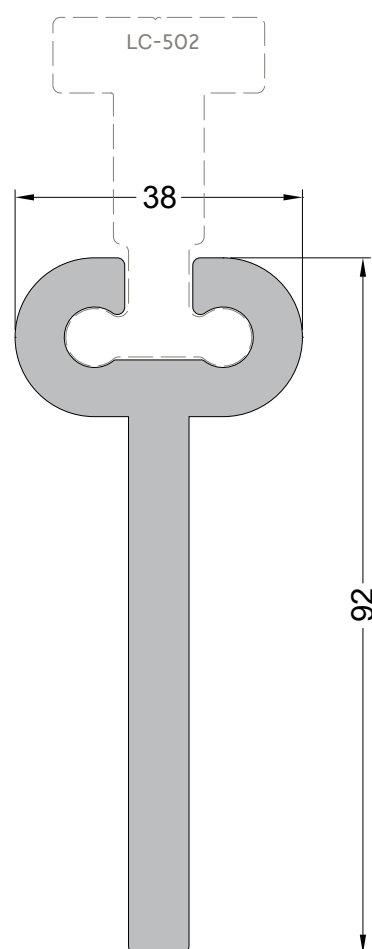

LC-509  
2,876 kg/m  
Apoio de Regulagem

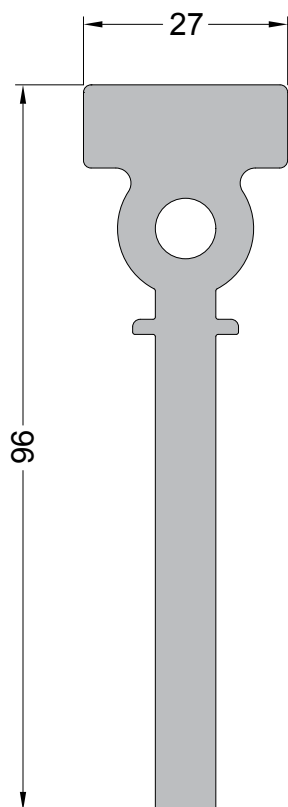

LC-513  
2,399 kg/m  
Apoio de Regulagem

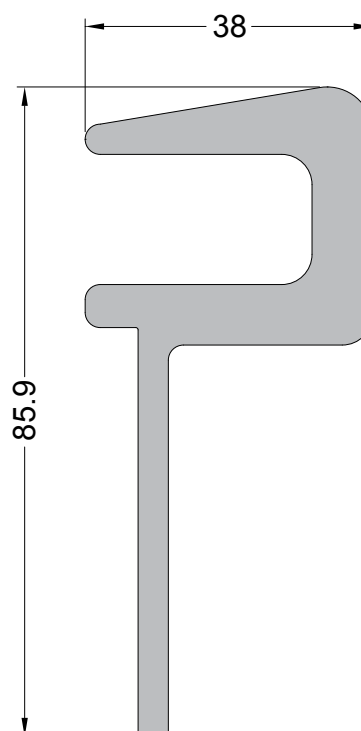

LC-501  
4,475 kg/m  
Ancoragem

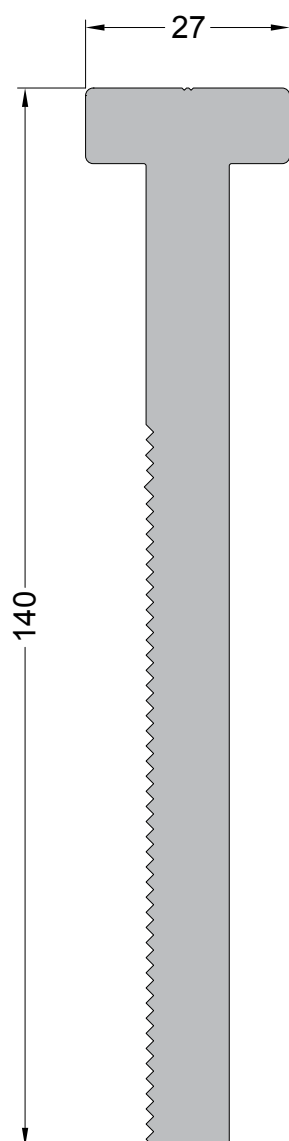

LC-510  
2,619 kg/m  
Ancoragem

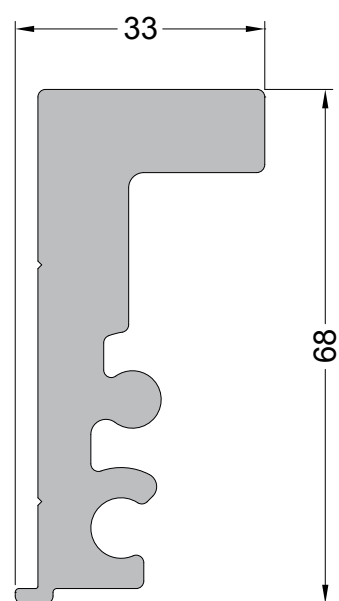

LC-504  
1,123 kg/m  
Guia Regulagem

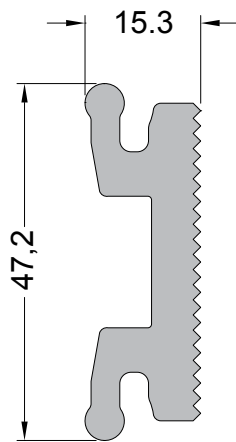

LC-505  
0,666 kg/m  
Arruela

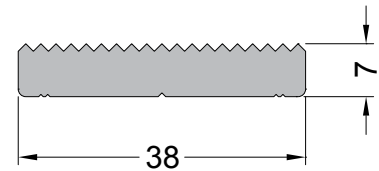

LC-507  
3,725 kg/m  
Extensor Horizontal

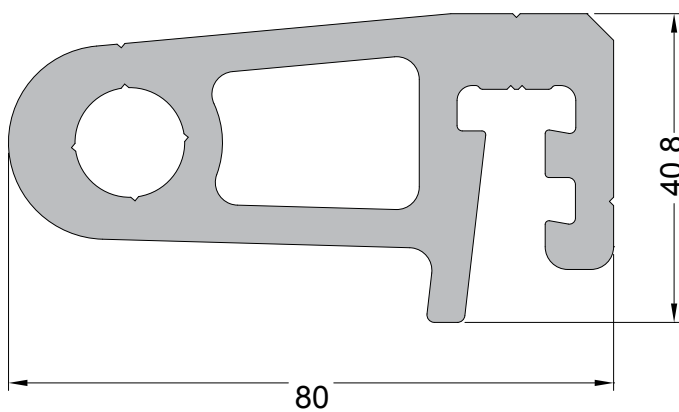

LC-502  
2,007 kg/m  
Gancho de Regulagem

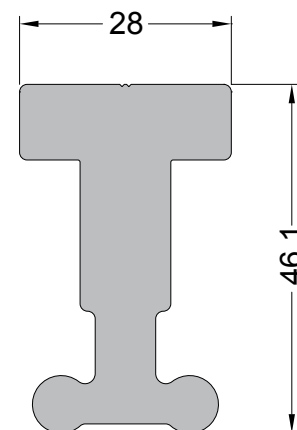



LC-520

1,194 kg/m

Barra de Ligação

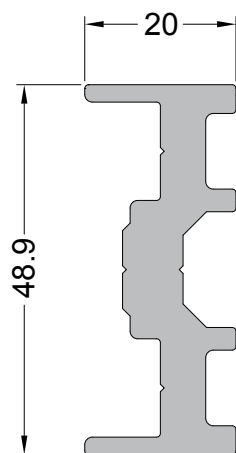

LC-521

1,694 kg/m

Barra de Ligação

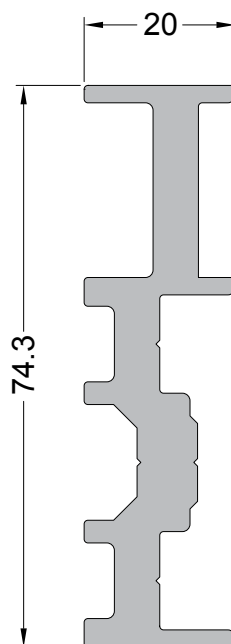

LC-522

1,035 kg/m

Barra de Ligação

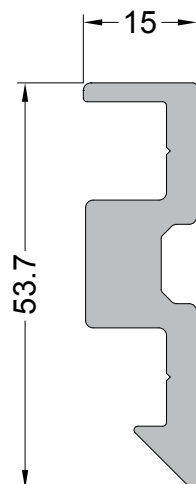

LC-523

2,071 kg/m

Barra de Ligação

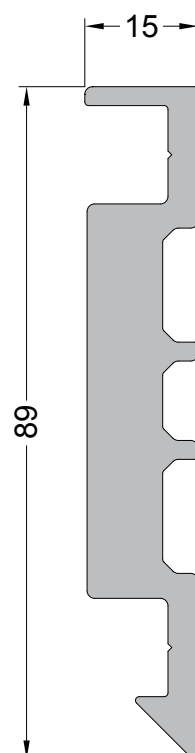

LC-530  
0,396 kg/m  
Trava

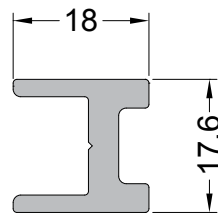

LC-83101  
1,122 Kg/m  
Ancoragem

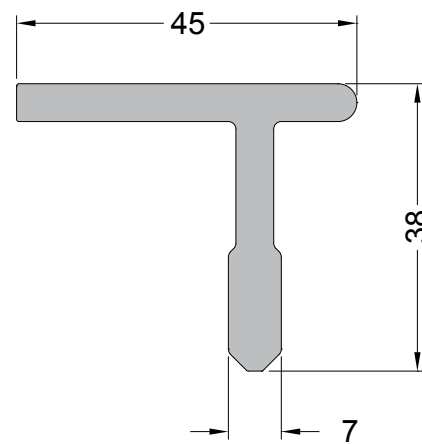

LC-512  
3,352 Kg/m  
Ancoragem



LC-251

0,383 Kg/m

Presilha

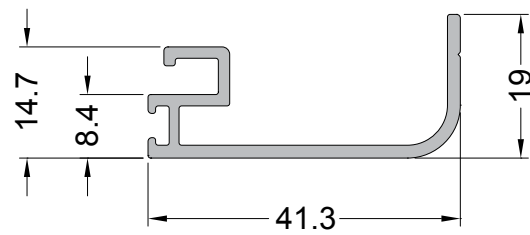

LC-252

0,473 Kg/m

Presilha

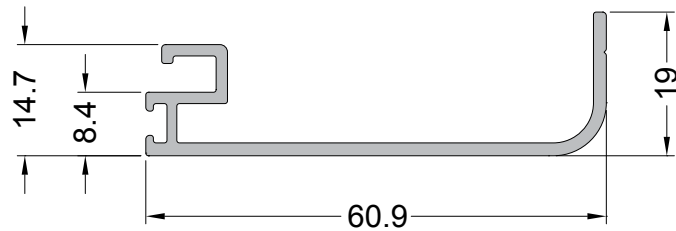

LC-255

0,290 Kg/m

Arremate

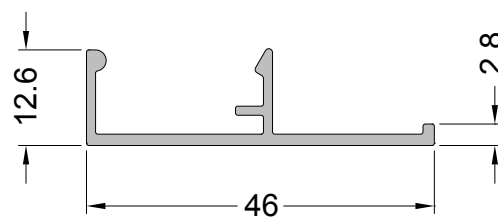

LC-261  
0,341 Kg/m  
Arremate

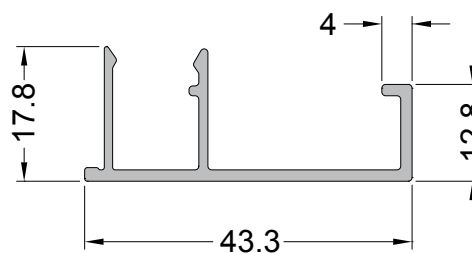

LC-262  
0,366 Kg/m  
Arremate Lateral

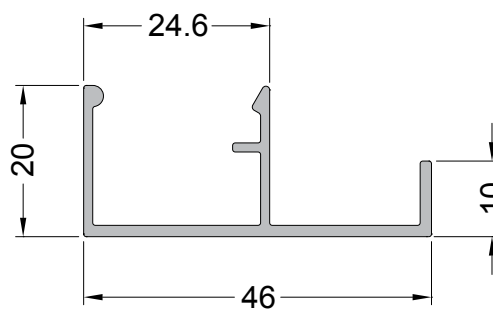

LC-263  
0,436 Kg/m  
Arremate Lateral

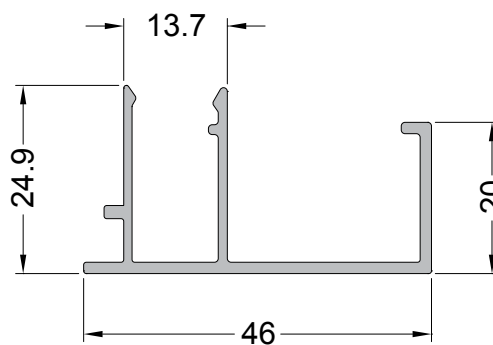

LC-71601  
0,446 Kg/m  
Arremate  
Entre-Vão

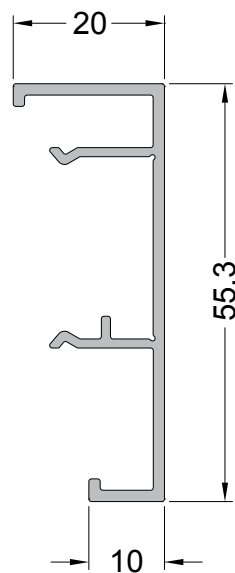

LC-71001  
0,366 Kg/m  
Arremate

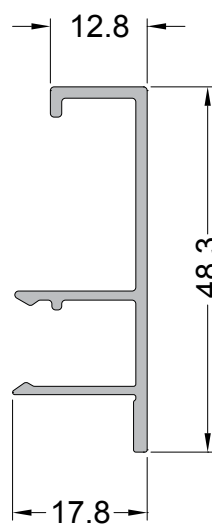

LC-71801  
0,435 Kg/m  
Arremate  
Entre-Vão

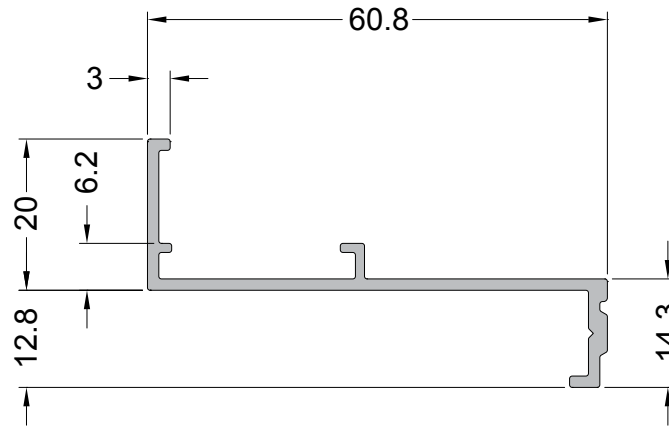

LC-71802  
0,604 Kg/m  
Arremate  
Entre-Vão

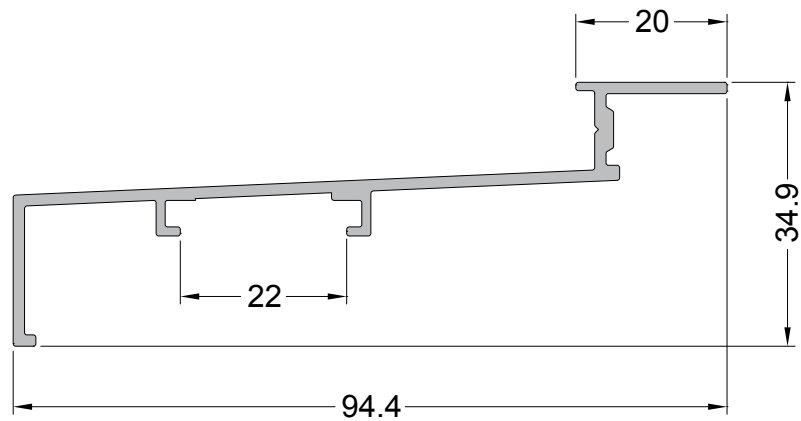

LC-82102  
0,430 Kg/m  
Complemento

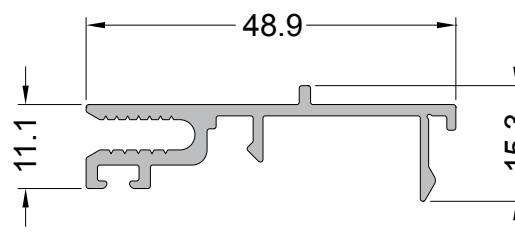

LC-82101

0,286 Kg/m

Complemento da Travessa

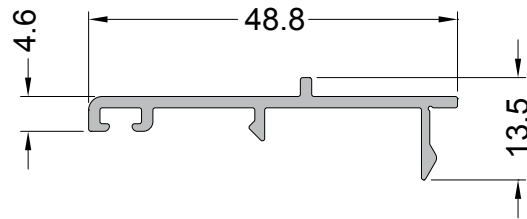

LC-85801

0,356 Kg/m

Complemento

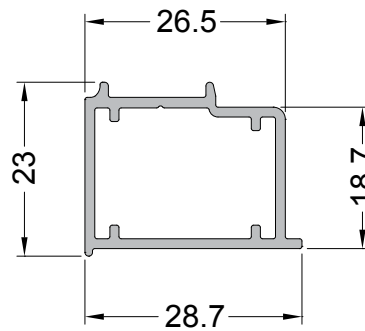

LC-85802

0,501 Kg/m

Complemento

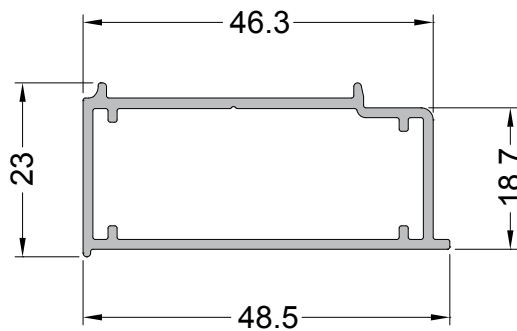

MO-001  
1,422 Kg/m  
Corrimão Vidro

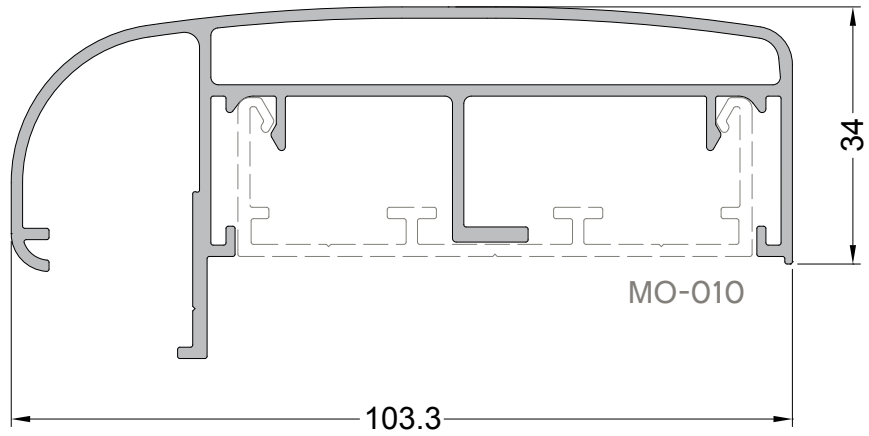

MO-002  
1,095 Kg/m  
Corrimão

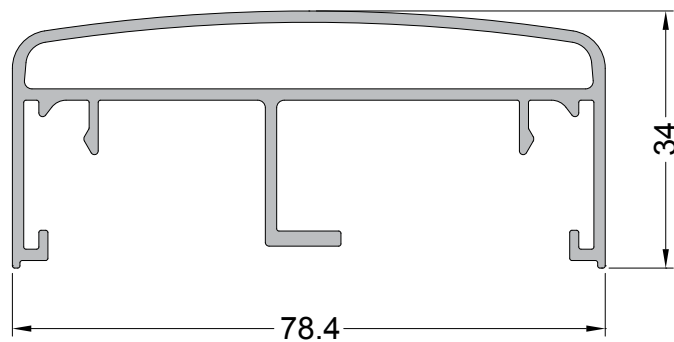

MO-003  
1,698 Kg/m  
Corrimão Vidro

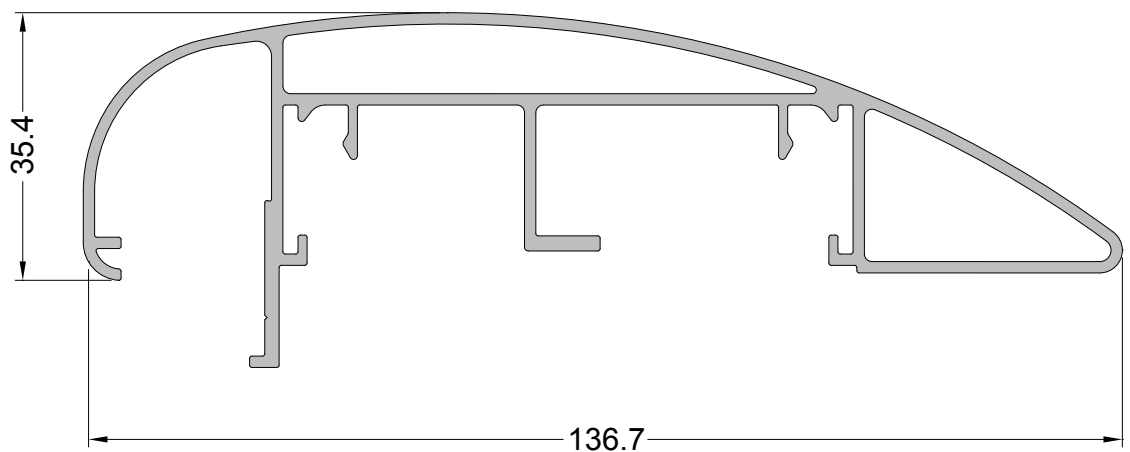



MO-004

1,386 Kg/m

Corrimão Vidro/Barrote

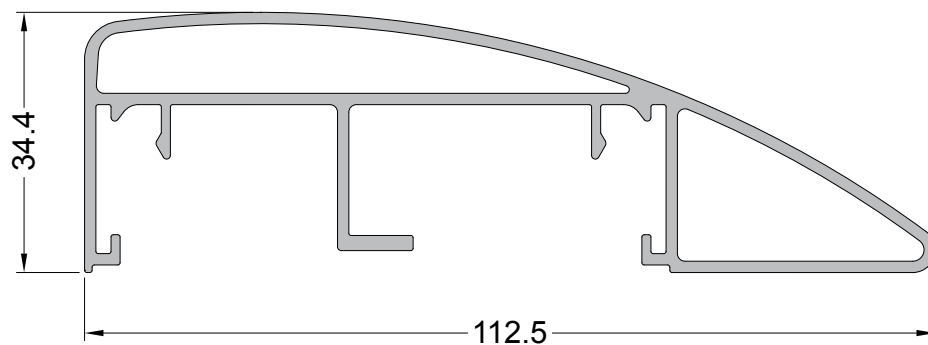

MO-005

1,274 Kg/m

Corrimão Vidro/Barrote

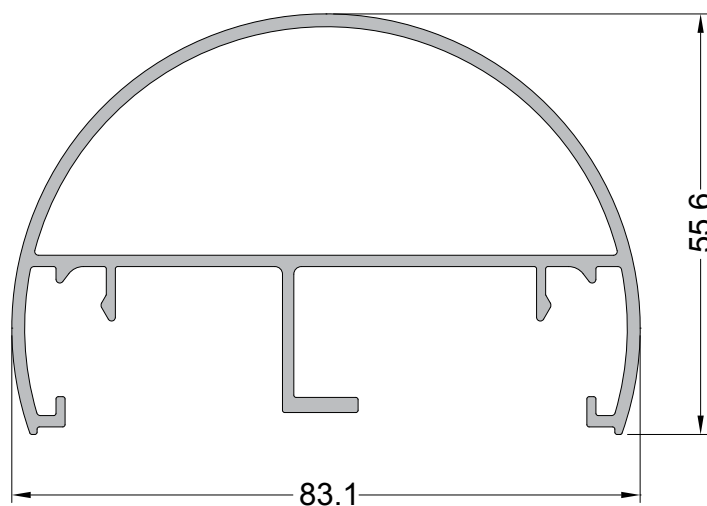

MO-008

1,229 Kg/m

Corrimão Vidro

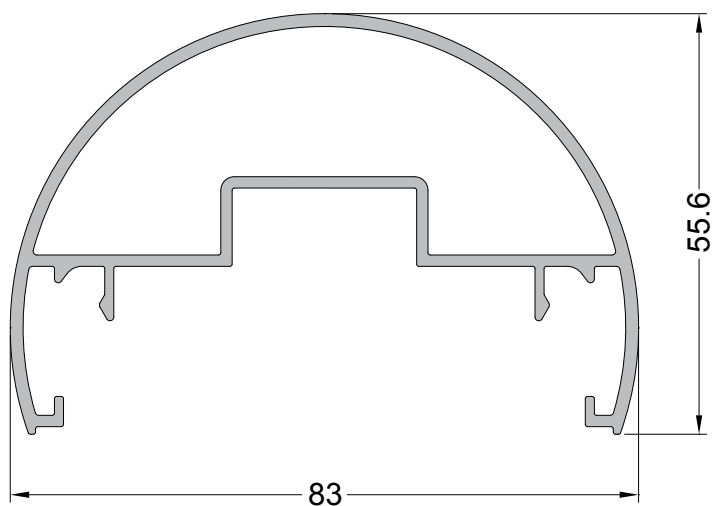

MO-007  
1,635 Kg/m  
Corrimão Vidro

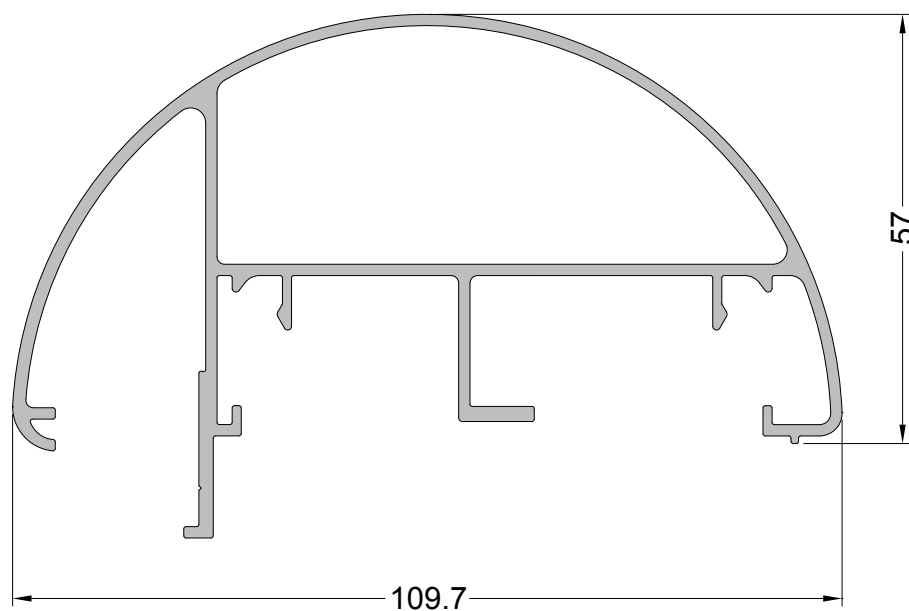

MO-77101  
1.678 Kg/m  
Corrimão

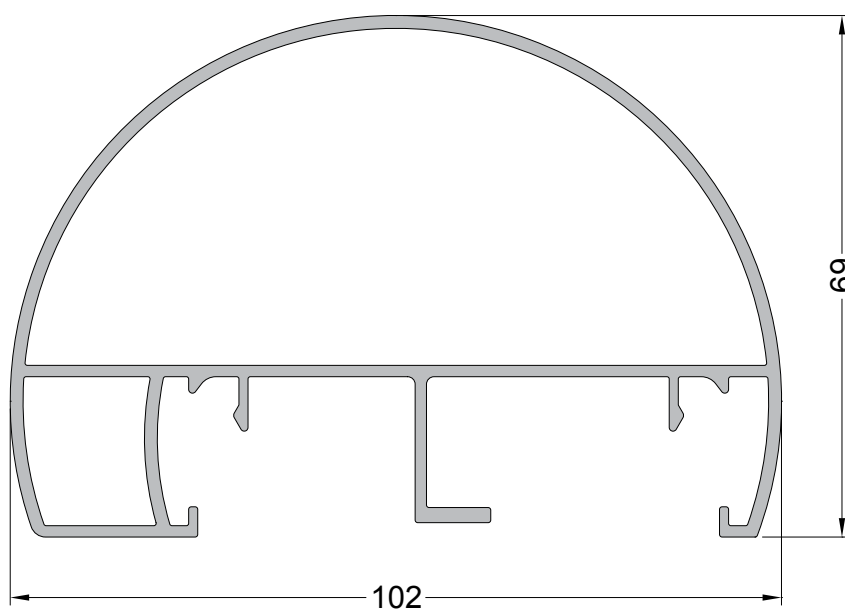

MO-77102

1.844 Kg/m

Corrimão

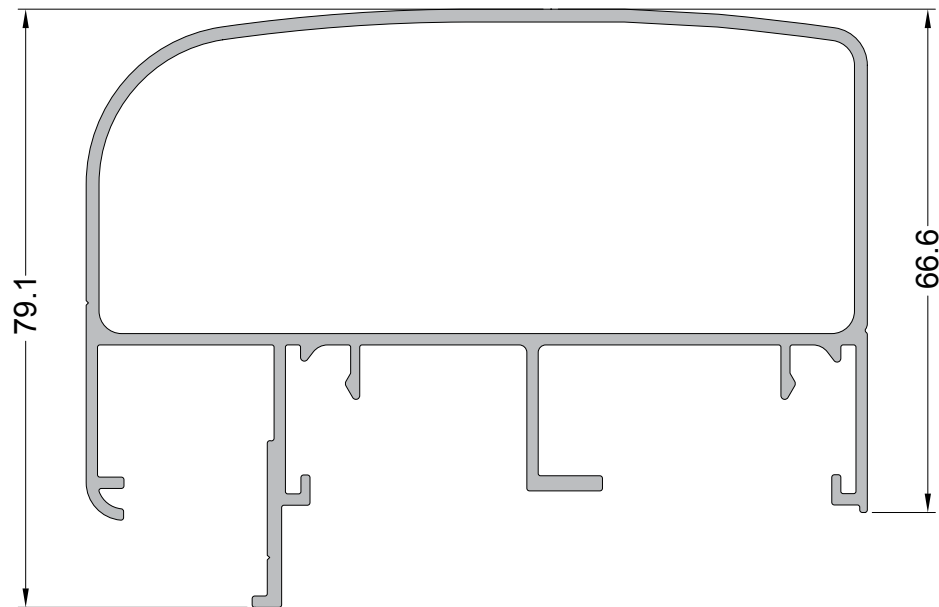

MO-010

0,598 Kg/m

Base Corrimão

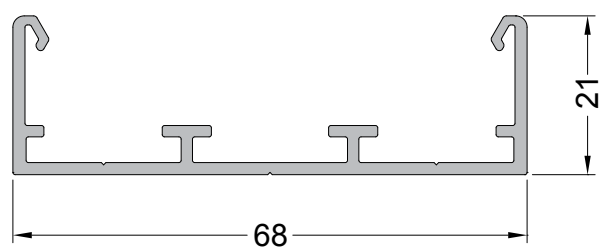

MO-020  
1,274 Kg/m  
Montante Retangular

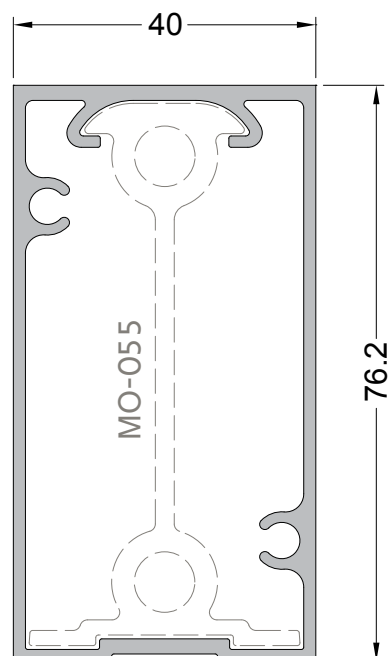

MO-021  
1,102 Kg/m  
Montante Arredondado

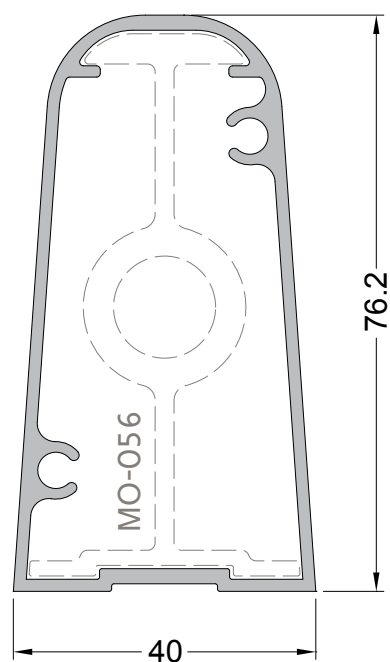

MO-022

1,909 Kg/m

Montante de Canto

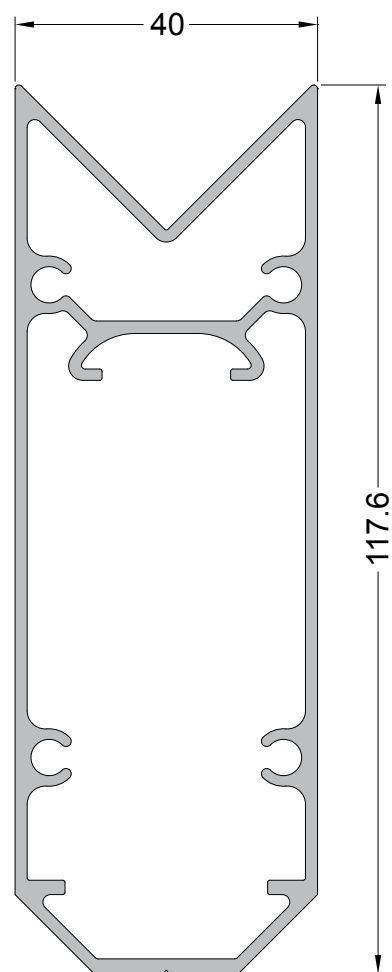

MO-023

1,392 Kg/m

Montante Duplo

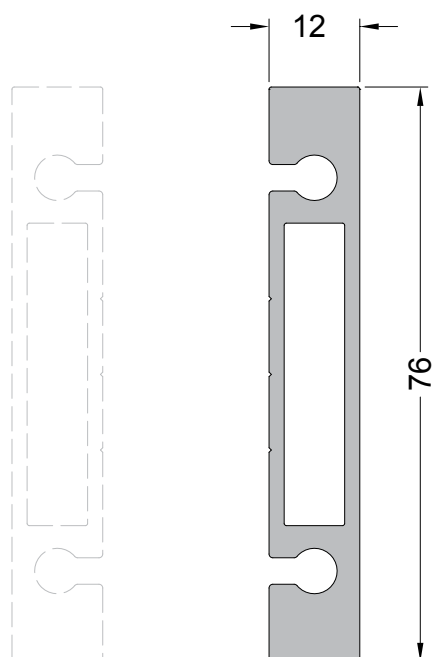

MO-033  
0,967 Kg/m  
Apoio Vidro

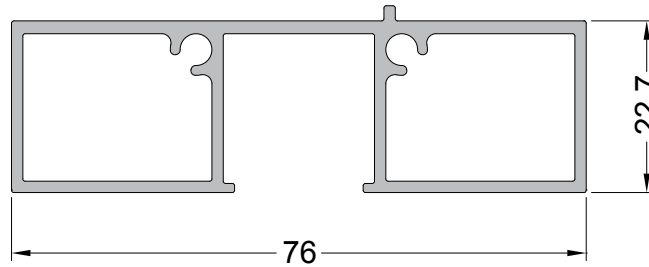

MO-030  
0,492 Kg/m  
Apoio Vidro

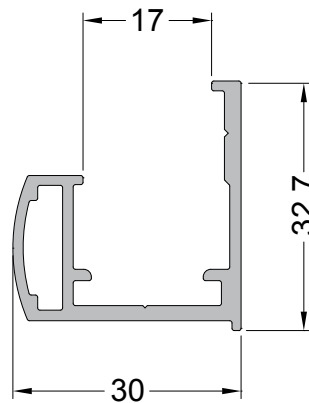

MO-038  
0,848 Kg/m  
Apoio vidro

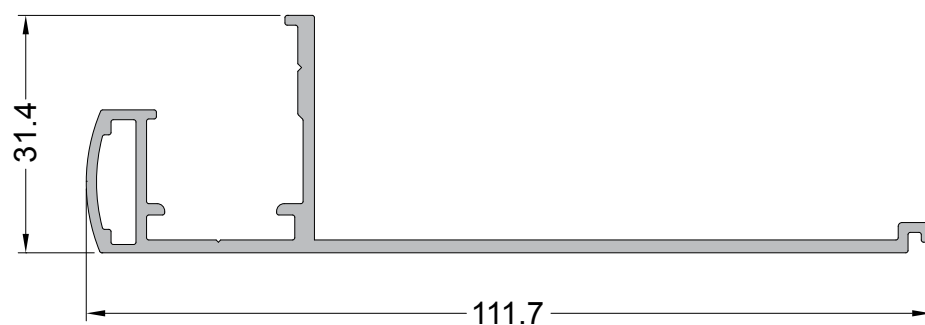

MO-035  
0,177 Kg/m  
Tampa

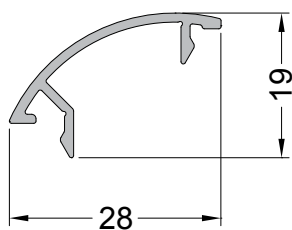

MO-036 (IF-036)  
0,199 Kg/m  
Tampa

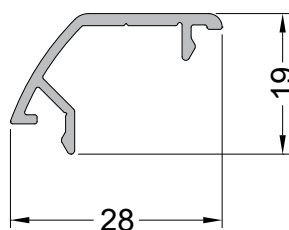

MO-037  
0.295 Kg/m  
Tampa

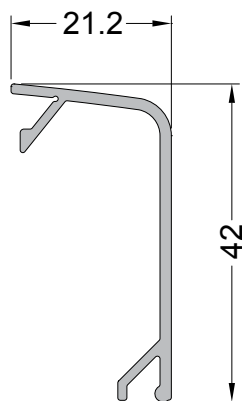

MO-040  
0,332 Kg/m  
Barrote Trapezoidal

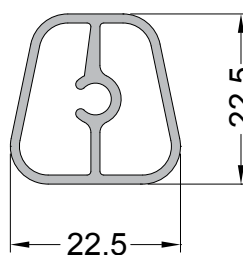

MO-74901  
0,795 Kg/m  
Barrote

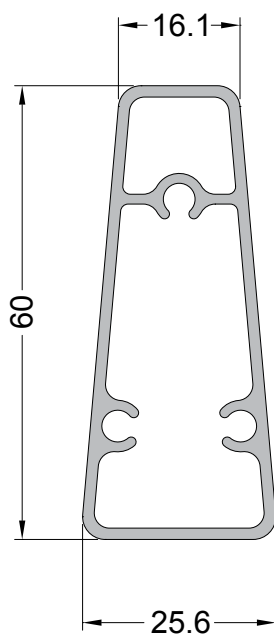

MO-500 (CX-3209)

3,479 Kg/m

Ancoragem

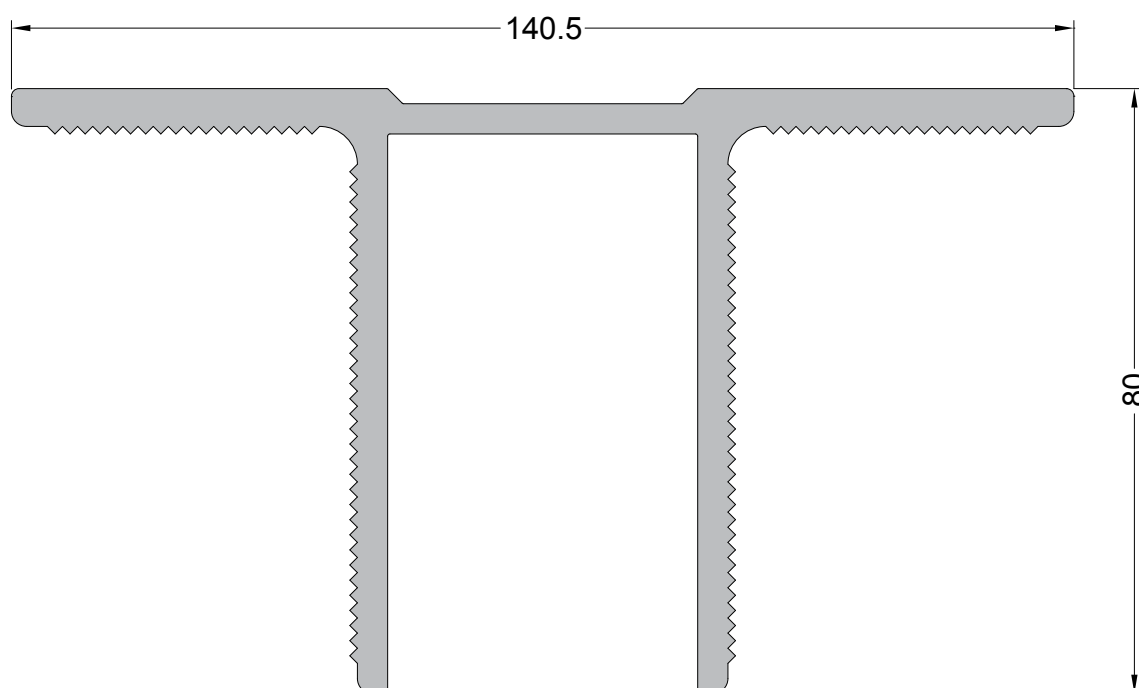

MO-501 (CX-3208)

1,505 Kg/m

Ancoragem

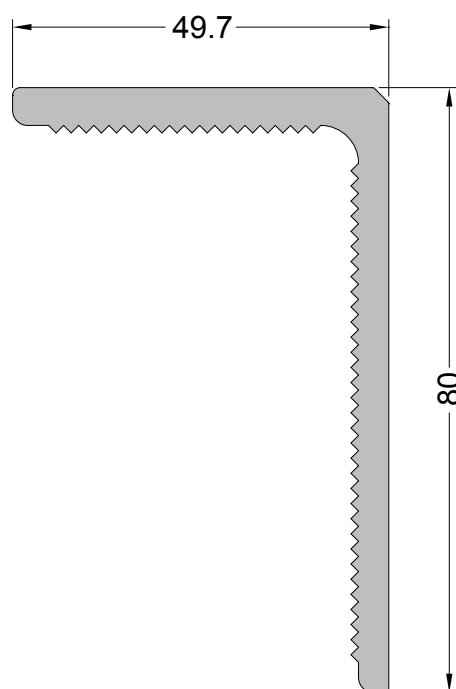



MO-055  
1,126 Kg/m  
Pontaleta

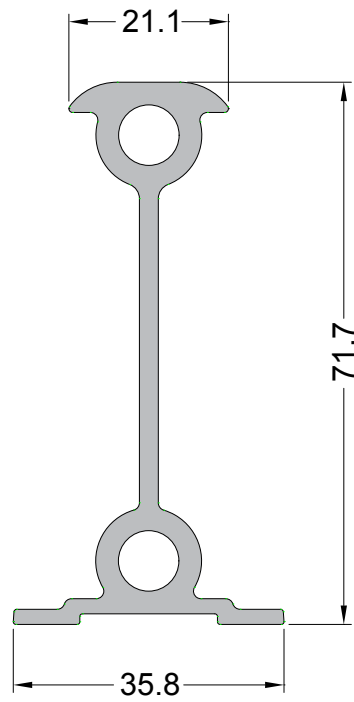

MO-056 (IF-056)  
1,296 Kg/m  
Pontaleta

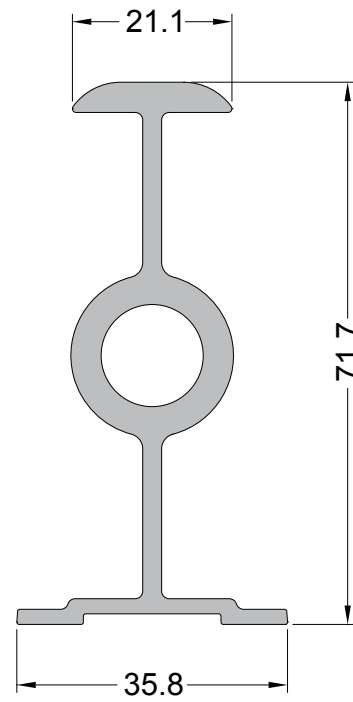

AP-417  
6.593 Kg/m  
Coxim

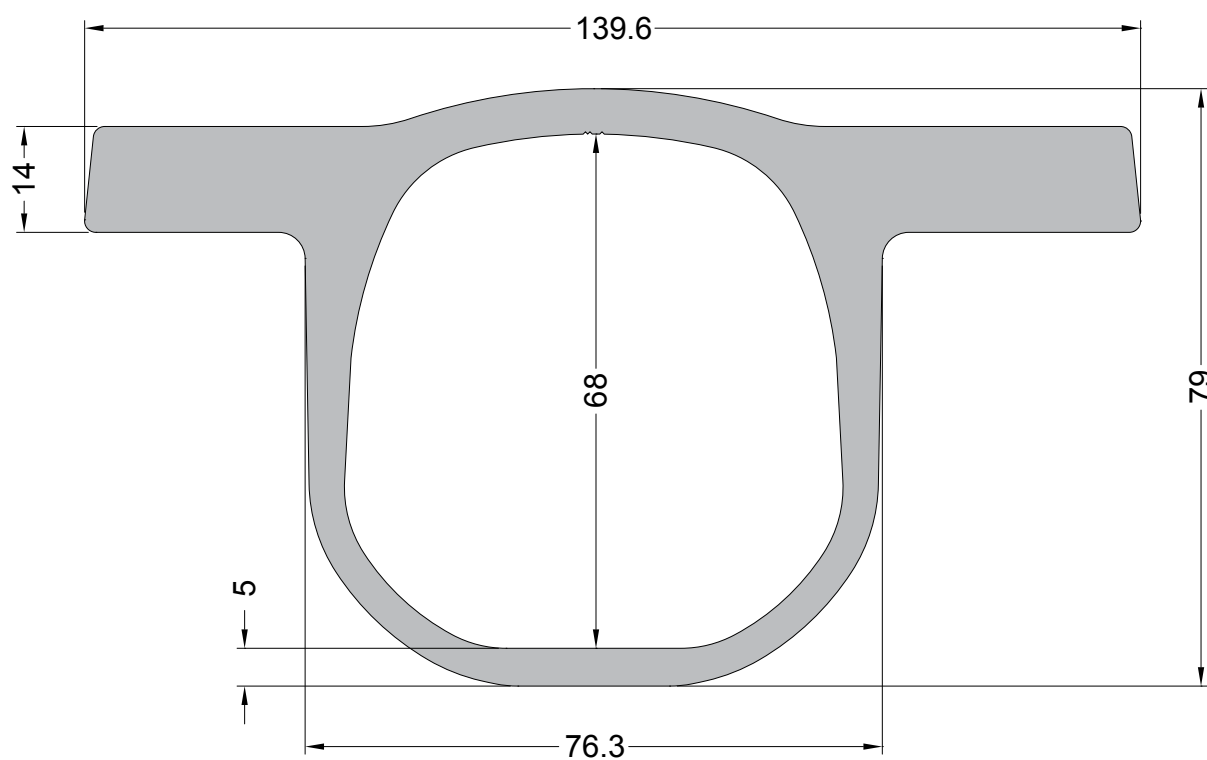

AP-474  
2.144 Kg/m  
Peça para Indústria  
Automotiva

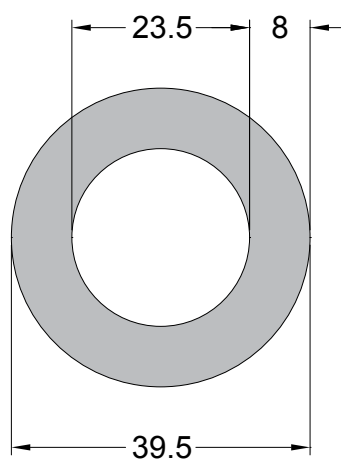

CX-496

4.398 Kg/m

Chassi

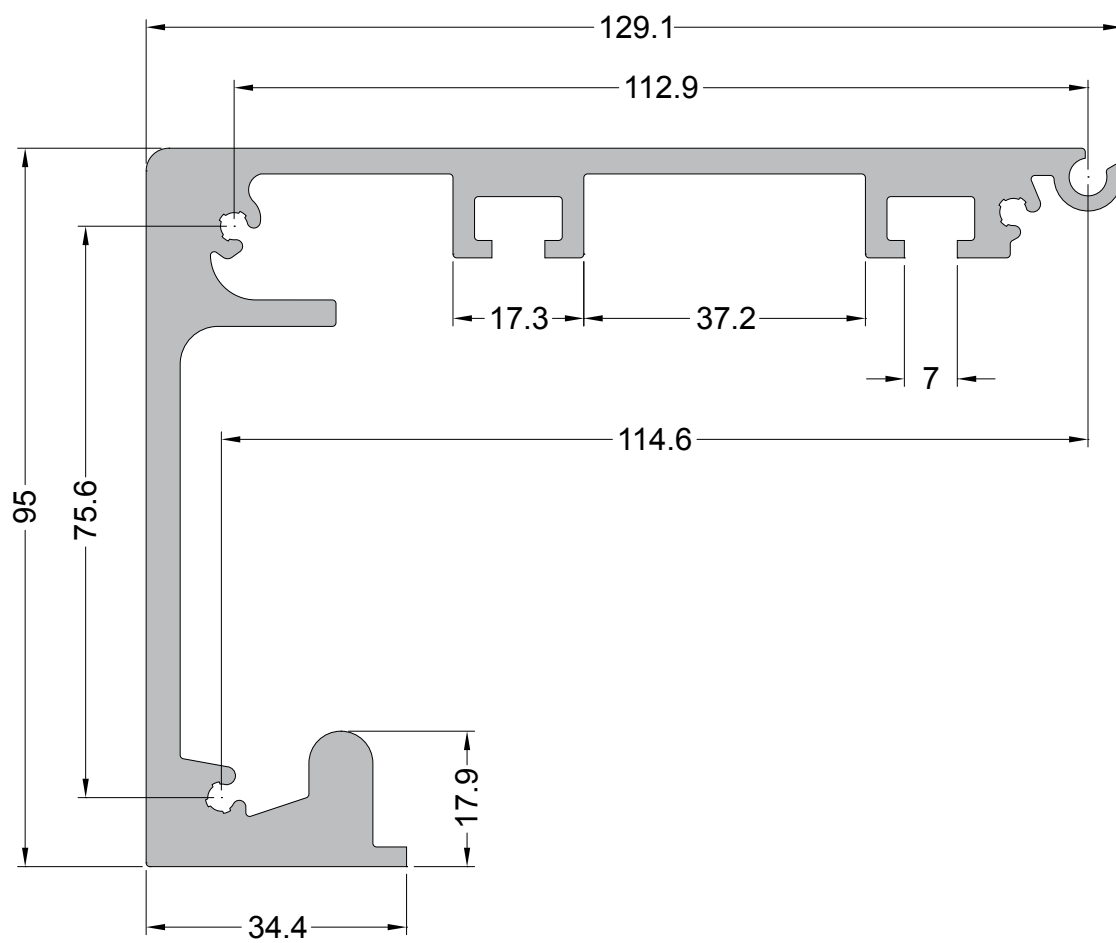

BK-5042  
0.405 Kg/m  
Dissipador

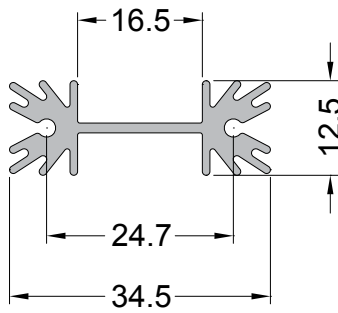

BK-5043  
0.365 Kg/m  
Dissipador

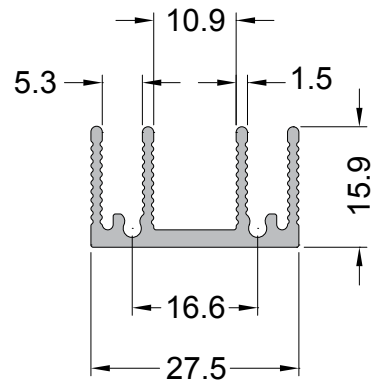

BK-5072  
0.281 Kg/m  
Dissipador

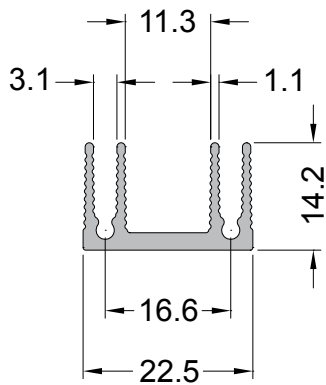

BK-5073  
0.528 Kg/m  
Dissipador

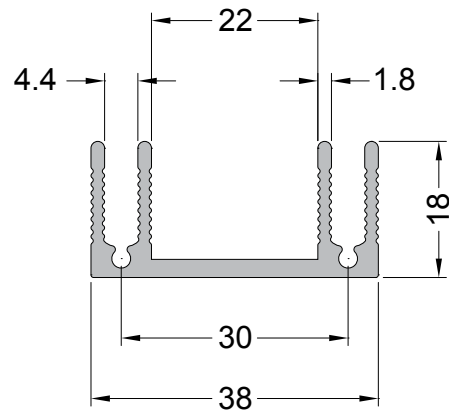

EE-466

2.301 Kg/m

Dissipador

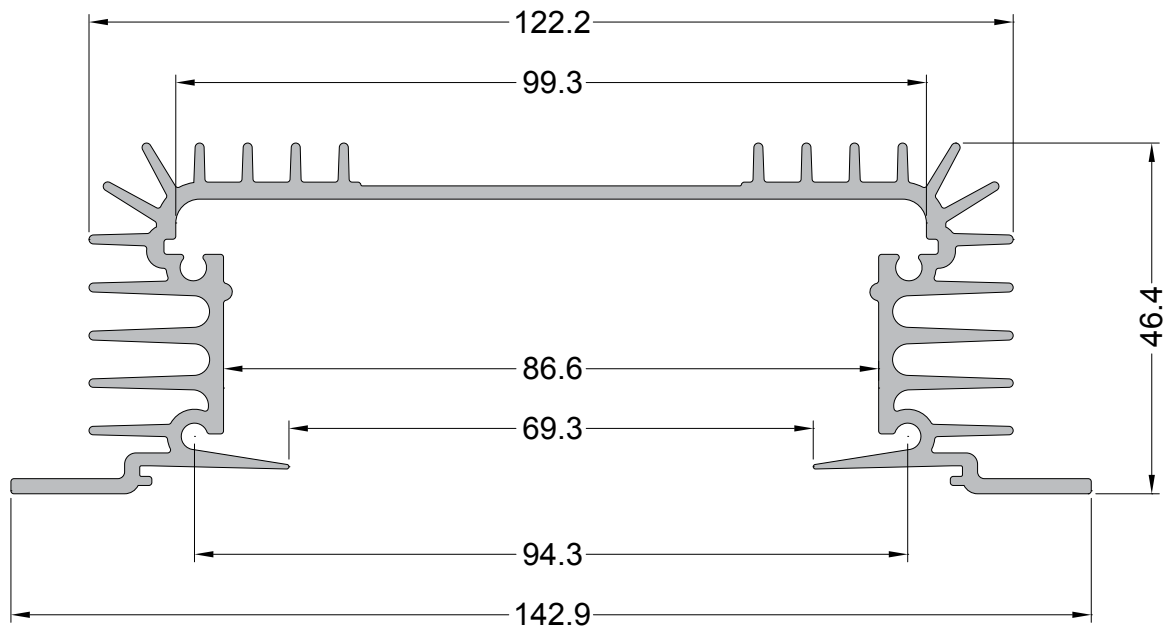

EE-465

2.469 Kg/m

Dissipador

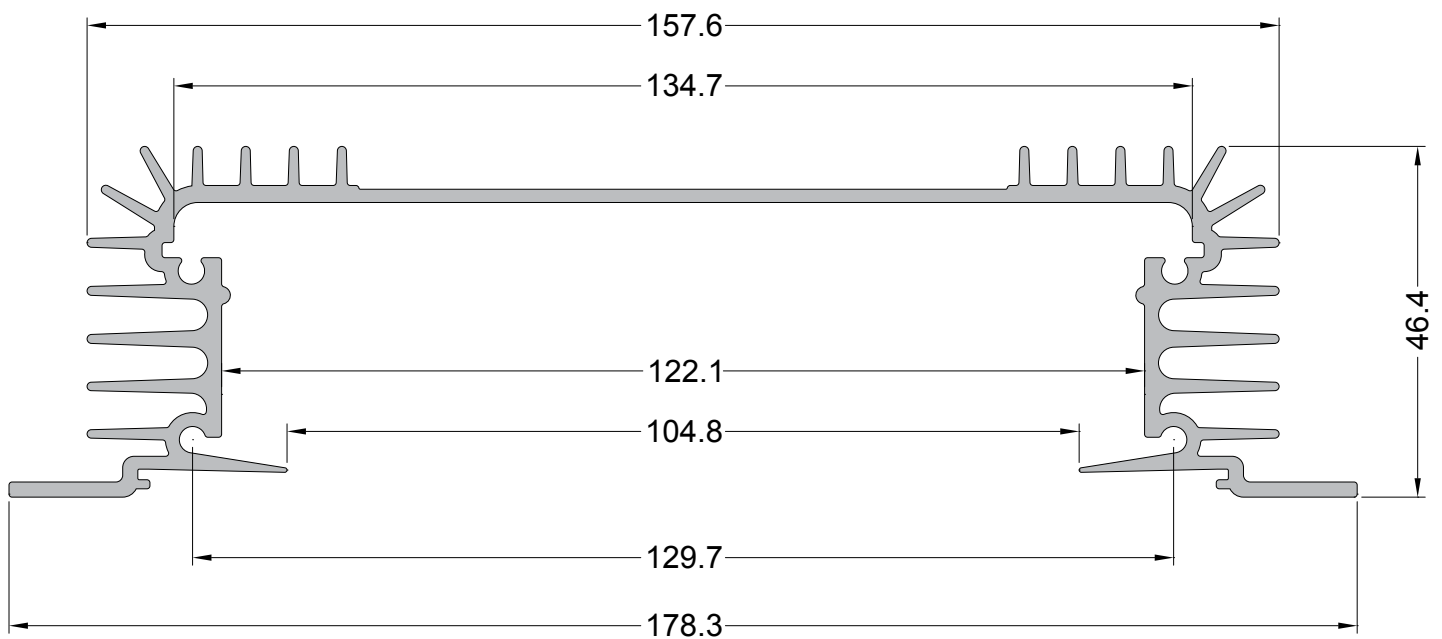

BK-486

3.293 Kg/m

Equipamento - Prensas

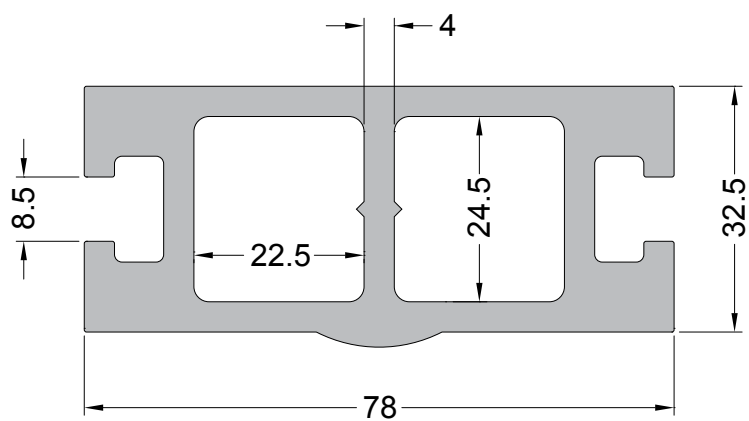

E-029

0.630 Kg/m

Luminosos

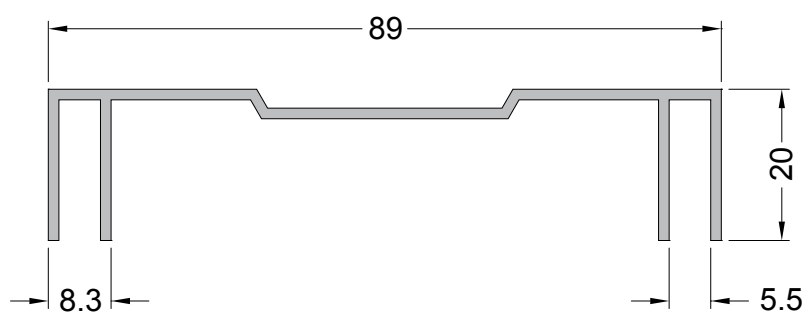

E-201

1.036 Kg/m

Luminosos

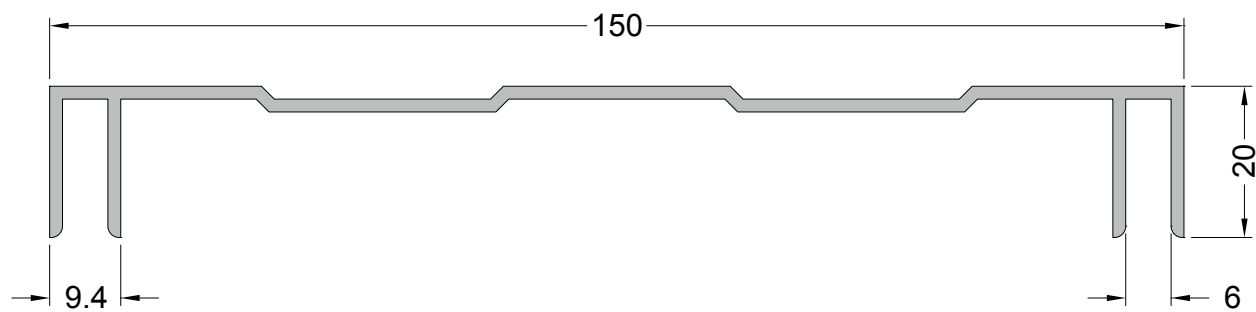

E-202

1.030 Kg/m

Luminosos

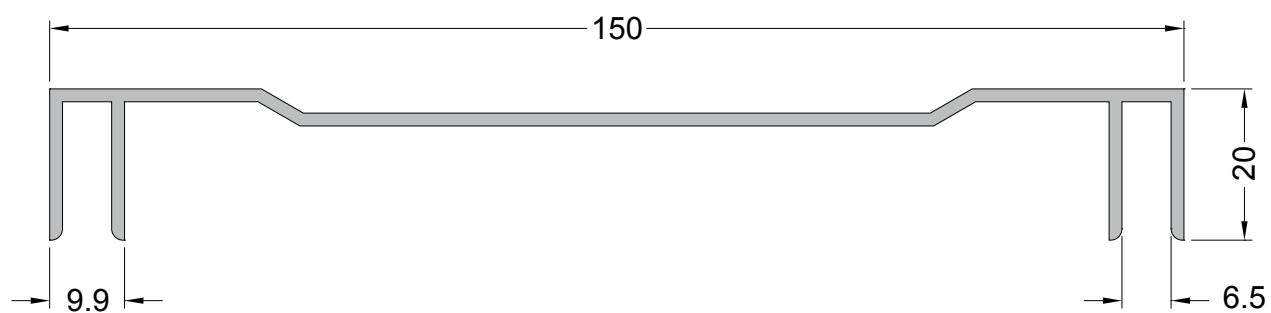

E-252

0.151 Kg/m

Vitrine

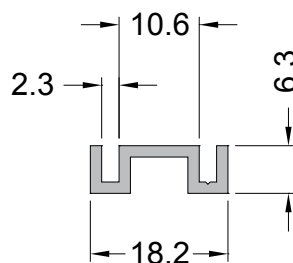

E-463

0.225 Kg/m

Vitrine

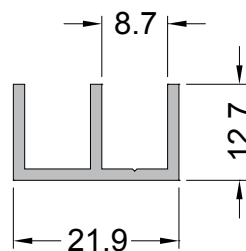

I-151

0.209 Kg/m

Vitrine

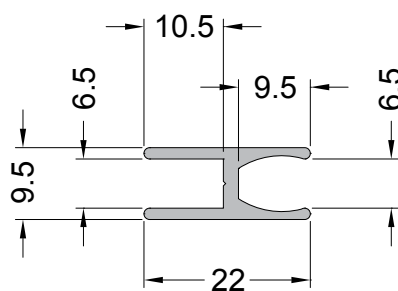









HIGH QUALITY IN ALUMINIUM

■ **Unidade CDA Santo André**

Av. Dos Estados, 3913 – Santa Teresinha  
Santo André – SP - 09210580  
PABX: (11) 4996-7000 ou 4996-7100  
FAX: (11) 4996-7138  
E-mail: cdabr@cdametais.com.br

■ **Unidade CDA Diadema**

Av. Maria Leonor, 1067 – Jardim Campanário  
Diadema – SP – 09920-080  
PABX: (11) 4093-9900 ou 3623-2233  
FAX: (11) 4093-9988  
E-mail: cdametais@cdametais.com.br

■ **Unidade CDA Curitiba**

Av. Senador Salgado Filho, 216 C – Prado Velho  
Curitiba – PR – 80215-270  
PABX: (41) 3063-3000  
FAX: (41) 3063-3004  
E-mail: cdapr@cdametais.com.br

■ **Unidade CDA Rio de Janeiro**

Av. Postal, 34 – Ramos  
Rio de Janeiro – RJ – 21040-150  
PABX: (21) 3534-5300  
FAX: (21) 3534-5305  
E-mail: cdarj@cdametais.com.br

■ **Unidade CDA Porto Alegre**

Av. das Indústrias, 130 – São João  
Porto Alegre – RS – 90200-290  
PABX: (51) 3373-2333  
FAX: (51) 3373-2300  
E-mail: cdars@cdametais.com.br